

# AETECHRON



## 9100 Series

### Operator's Manual

*Wide-Bandwidth, High-Power, Single-Channel Digital Amplifiers*



## Three-Year, No-Fault Warranty

### SUMMARY OF WARRANTY

**AE TECHRON INC.**, of Elkhart, Indiana (Warrantor) warrants to you, the ORIGINAL COMMERCIAL PURCHASER and ANY SUBSEQUENT OWNER of each NEW **AE TECHRON INC. product, for a period of three (3) years from the date of purchase, by the original purchaser (warranty period) that the product is free of defects in materials and workmanship and will meet or exceed all advertised specifications for such a product. We further warrant the new AE Techron product regardless of the reason for failure, except as excluded in the Warranty.**

### ITEMS EXCLUDED FROM WARRANTY

This AE Techron Warranty is in effect only for failure of a new AE Techron product which occurred within the Warranty Period. It does not cover any product which has been damaged because of any intentional misuse, or loss which is covered under any of your insurance contracts. This warranty does not extend to any product on which the serial number has been defaced, altered, or removed. It does not cover damage to loads or any other products or accessories resulting from **AE TECHRON INC.** product failure. It does not cover defects or damage caused by the use of unauthorized modifications, accessories, parts, or service.

### WHAT WE WILL DO

We will remedy any defect, regardless of the reason for failure (except as excluded), by repair or replacement, at our sole discretion. Warranty work can only be performed at our authorized service centers or at our factory.

Expenses in remedying the defect will be borne by **AE TECHRON INC.**, including one-way surface freight shipping costs within the United States. (Purchaser must bear the expense of shipping the product between any foreign country and the port of entry in the United States and all taxes, duties, and other customs fees for such foreign shipments.)

### HOW TO OBTAIN WARRANTY SERVICE

When you notify us or one of our authorized service centers of your need for warranty service, you will receive an authorization to return the product for service. All components must be shipped in a factory pack or equivalent which, if needed, may be obtained

from us for a nominal charge. We will take corrective actions and return the product to you within three weeks of the date of receipt of the defective product, or will make available to you a product of equal or better performance on temporary loan until your product can be repaired or replaced and returned to you. If the repairs made by us are not satisfactory, notify us immediately.

### DISCLAIMER OF CONSEQUENTIAL AND INCIDENTAL DAMAGES

You are not entitled to recover from us any consequential or incidental damages resulting from any defect in our product. This includes any damage to another product or products resulting from such a defect.

### WARRANTY ALTERATIONS

No person has the authority to enlarge, amend, or modify this warranty. The warranty is not extended by the length of time for which you are deprived of the use of this product. Repairs and replacement parts provided under the terms of this warranty shall carry only the unexpired portion of this warranty.

### DESIGN CHANGES

We reserve the right to change the design of any product from time to time without notice and with no obligation to make corresponding changes in products previously manufactured.

### LEGAL REMEDIES OF PURCHASER

There is no warranty that extends beyond the terms hereof. This written warranty is given in lieu of any oral or implied warranties not contained herein. We disclaim all implied warranties, including, without limitation, any warranties of merchantability or fitness for a particular purpose. No action to enforce this Warranty shall be commenced later than ninety (90) days after expiration of the warranty period. This statement of warranty supersedes any others contained in this manual for AE Techron products.

### **AE TECHRON INC.**

#### **Customer Service Department**

2507 Warren St. Elkhart, IN, 46516, U.S.A.  
(574) 295-9495  
www.aetechron.com

# Contents

<b>1</b>	<b>Introduction</b>	<b>5</b>
1.1	Features	5
<b>2</b>	<b>Amplifier Unpacking and Installation</b>	<b>6</b>
2.1	Safety First	6
2.2	Unpacking	6
2.3	Installation	6
<b>3</b>	<b>Connections and Startup</b>	<b>7</b>
3.1	Connecting the Load	7
3.2	Connecting the Input Signal	7
3.3	Optional Controls and Connectors	8
3.4	Connecting the AC Supply	8
<b>4</b>	<b>Amplifier Operation</b>	<b>10</b>
4.1	Front-Panel Controls and Indicators	10
4.2	Back-Panel Controls & Connectors	11
<b>5</b>	<b>Advanced Configuration</b>	<b>13</b>
5.1	DIP Switch Configurations	13
5.2	Custom Compensation	16
<b>6</b>	<b>Applications</b>	<b>17</b>
6.1	Emergency Standby Switch or Safety Interlock	17
6.2	Controlled-Voltage vs. Controlled-Current Modes of Operation	17
6.3	Driving Reactive Loads	20
<b>7</b>	<b>Maintenance</b>	<b>21</b>
7.1	Clean Amplifier Filter and Grills	21
<b>8</b>	<b>Troubleshooting</b>	<b>22</b>
8.1	Introduction & Precautions	22
8.2	No Signal	22
8.3	No LEDs Illuminated	22
8.4	Over/Under Line LED Lit	22
8.5	Run/Standby LED Remains Amber	22
8.6	Amplifier Overheats (Over Temp Fault Condition)	22
8.7	Fault LED is Illuminated	23
8.8	Factory Service	23



Figure 1.1 – 9105 Front Panel

## 1 Introduction

Congratulations on your purchase of a 9100 Series digital power amplifier. 9100 Series amplifiers are 200Vp, DC-to-250 kHz capable amplifiers that offer a unique combination of switch-mode efficiency and linear-amplifier-like fidelity in a single, compact package. They are able to drive virtually any type of load without a reduction in rated power, with low distortion and low DC drift. They are also fast enough to meet 5µs surge and dropout requirements.

The 9100 series is a powerful and flexible partner when the environment is difficult or existing AC Mains options are limited. It is able to be powered from any normal single-phase AC mains voltage (100VAC — 250VAC). It is power-efficient, producing up to 2,000 watts output from a 20A, 120V AC mains supply, and up to 5 kW\* from 230V or 240V sources.

This combination of features makes the 9100 series an ideal solution for a wide range of high-current, low-voltage applications that require both DC power and quick surges or drop-outs, like those found in conducted immunity testing of DC-powered systems in the automotive and aviation markets.

\*9105 output is 4.5 kW from 230V or 240V sources; output for all other models is 5 kW.

Performance Overview	
<b>Bandwidth</b>	DC - 250 kHz
<b>Minimum Drop/Rise Time</b>	5µs
<b>Slew Rate</b>	Up to 150 V/µs
<b>Max Voltage</b>	0 to 200 V <sub>p</sub>
<b>Max Current</b>	Up to 50 to 150 A <sub>p</sub>
<b>Distortion</b>	<0.1% at 1 kHz below clip
<b>Max Long-Term Power</b>	5 kW to 30 kW**
<b>Typical Output Ripple</b>	0.6V RMS

\*\*Models available with output power from 5 kW to 30 kW (capable of up to 60 kVA).

### 1.1 Features

- Stable when driving highly capacitive loads.
- Four-quadrant operation.
- Fixed or variable gain.
- User-selectable current limit to protect fragile DUTs or where specified in the Standard.
- DC enabled or DC blocked and DC Servo (for driving transformer-coupled loads or coils).
- Balanced and/or unbalanced input.
- Operate as a voltage-controlled voltage source or voltage-controlled current source.
- Variable output impedance from 0 to 1 ohm (Voltage mode).



Figure 2.1 – 9105 Back Panel

## 2 Amplifier Unpacking and Installation

The 9100 series amplifier is a precision instrument that can be dangerous if not handled properly. Lethal voltages are present in both the AC input supply and the output of the amplifier. For this reason, safety should be your primary concern when you setup and operate this amplifier.

### 2.1 Safety First

Throughout this manual special emphasis is placed on good safety practices. The following graphics are used to highlight certain topics that require extra precaution.

	<b>WARNING</b>
<p><b>WARNING</b> alerts you to hazards that could result in severe injury or death. Note the explanation of the hazard and the instructions for avoiding it.</p>	

	<b>CAUTION</b>
<p><b>CAUTION</b> indicates hazards that could result in potential injury or equipment or property damage. Once again, note the explanation of the hazard and the instructions for avoiding it.</p>	

### 2.2 Unpacking

All amplifiers are tested and inspected for damage before leaving the factory. Carefully unpack and inspect the amplifier for damage. **Please note any damage for future reference and notify the shipping company immediately if damage is found.** Also, please save the shipping carton and

materials as evidence of damage and/or for returning the amplifier for repair.

### 2.3 Installation

The 9100 series amplifier is packaged in a rugged powder-coated chassis. This chassis is 2U (rack units) tall, and has rack “ears” on each side of the front panel for mounting to a standard EIA (Electronic Industries Association) rack. Use standard rack mounting hardware to mount the amplifier. Use nylon washers if you wish to protect the powder-coat finish on the front of the amplifier.

Optionally, the amplifier can be placed on a bench top; please keep in mind that the protective powder-coating can be scratched when placed on other equipment or on a bench top, especially when there is dirt present.

Allow ample space on the sides and especially the back of the amplifier for heated air to escape. The amplifier should be mounted in a rack that is adequately ventilated and not sealed. Likewise, the front of the amplifier should be unobstructed to allow cool air to enter the amplifier.

	<b>CAUTION</b>
<p>Do not operate the amplifier in a small sealed chamber of any kind. Improper operations and overheating will result.</p>	

### 3 Connections and Startup

This section details the wiring and startup procedures for an 9100 series amplifier operating in Controlled-Voltage mode (factory default). Before connecting the amplifier inputs and outputs, make sure AC power is disconnected.

#### Testing Before Controlled-Current Operation

**IMPORTANT:** If your application requires Controlled Current operation, the 9100 series amplifier first should be wired and tested in Controlled-Voltage mode to verify that the amplifier and input signal are operating correctly. Once proper operation is confirmed, refer to the **Applications** section of this manual for instructions on configuring and operating your amplifier in Controlled-Current mode.

#### 3.1 Connecting the Load

##### 3.1.1 Preparation and Cautions

**Before connecting the amplifier, make sure the AC power is disconnected.**

Always use the appropriate wire size and insulation for the maximum current and voltage expected at the output. Never connect the output of the amplifier to any other model amplifier, power supply, signal source, or other inappropriate load; fire can result.

	WARNING
ELECTRIC SHOCK HAZARD.	
Output potentials can be lethal. Output cover must remain installed at all times to protect against HAZARDOUS LIVE VOLTAGES	

##### 3.1.2 Output Connections

Connection to the output of the amplifier is to a high-current, two-terminal barrier block. Wires terminated with #10 spade or ring terminals are recommended when connecting to the output terminals. Connect the load across the terminals marked “+” (positive) and “-” (negative/ground). The negative terminal also can be connected to an external ground point such as the rack chassis, if desired. See **Figure 3.1**.

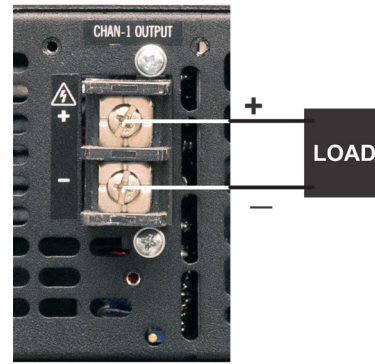

Figure 3.1 – Connecting the Load

Be sure to install the output safety cover after wiring the output connections. See **Figure 3.2**.

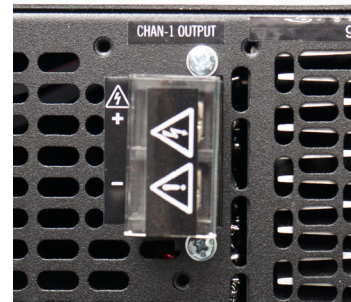

Figure 3.2 – Output Safety Cover

#### 3.2 Connecting the Input Signal

An unbalanced BNC connector is provided on the amplifier back panel for signal input. Connect your input signal source to the connector as shown in **Figure 3.3**. Use cables that are high quality and shielded to minimize noise and to guard against possible feedback.

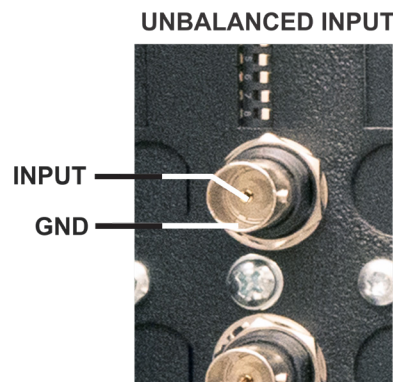

Figure 3.3 – Wiring for Unbalanced Input Connector

In addition, your 9100 series amplifier provides a balanced “WECO” terminal block connector for signal input on the back-panel SIM (Specialized Input Module). The SIM-91 module comes standard with all 9100 series amplifiers, but other SIM modules may be used instead for specialized applications. Information on alternate SIM modules will be found on a separate information sheet provided with the product, where applicable.

Connect your input signal source to the balanced input connector as shown in **Figure 3.4**.

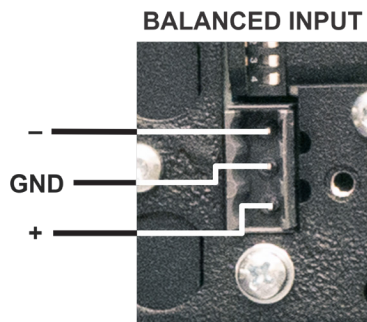

Figure 3.4 – Wiring for Balanced Input Connector

### 3.3 Optional Controls and Connectors

The following controls and connectors are provided on the amplifier back panel to allow for additional monitoring, configuration and control of the amplifier output.

#### 3.3.1 Current Monitor Connector

An unbalanced BNC port is provided on the amplifier back panel to allow for connection to current monitoring equipment. The current monitor output is  $1V = 20A$ .

#### 3.3.2 DIP Switches

DIP switches provided on the amplifier back panel and on the SIM module can be used to enable features or configure the amplifier for special applications. See the **Advanced Configuration** section of this manual for more information. Before operating the amplifier, check to make sure all DIP switches are set as intended.

#### 3.3.3 Remote Connectors

Two DB9 connectors are provided on the SIM-91 module for remote control and monitoring of the amplifier output. Please refer to the **Applications** section of this manual for more information.

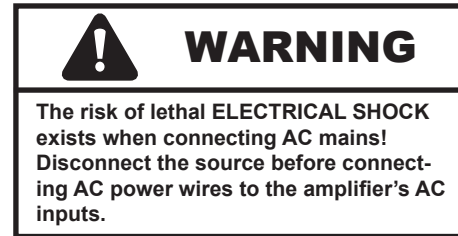

### 3.4 Connecting the AC Supply

#### 3.4.1 Disconnect and Inlet Wiring Protection

A safety disconnect device for the AC mains input must be installed so that it is both nearby and accessible to the operator. The disconnect must be clearly labeled.

Inlet wiring must support the rated current.

The amplifier must be protected by fuses or circuit breakers that protect the power inlet wiring with a maximum rating of no more than 30A (20A for 9105).

#### 3.4.2 AC Inlet Connections

Always operate the amplifier from the proper AC mains. The 9100 series amplifier requires single-phase, 50-60 Hz, 100-250 VAC, at 30A (20A for 9105) with no more than  $\pm 10\%$  variance above or below the line voltage. The amplifier will not operate properly outside these limits.

Connect protective grounding terminal to AC mains ground before turning on power to prevent electric shock hazard.

Do not disconnect or disable the protective grounding connection. Doing so causes a potential electrical shock hazard.

Connect the AC supply to the three-terminal barrier strip located on the amplifier back panel (see **Figure 3.5**).



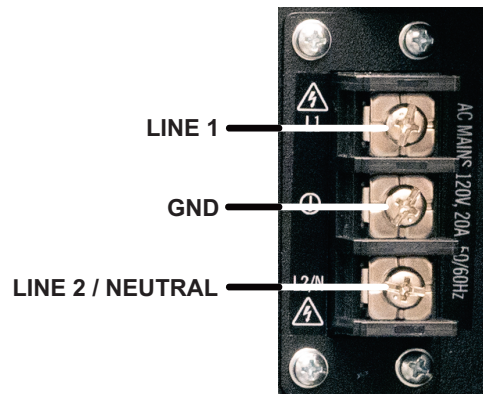

Figure 3.5 – AC Mains Barrier Strip Wiring

### Start-up Procedure

1. Turn down the level of your signal source.
2. Press the front-panel Standby-Run switch to the Run position to energize the amplifier.
3. Wait until the Run/Standby indicator turns solid green.
4. Adjust your input signal level to achieve the desired output level.

## 4 Amplifier Operation

### 4.1 Front-Panel Controls and Indicators

This section provides an overview of Front-Panel controls and indicators found on the 9100 series amplifier. Refer to **Figure 4.1** for component locations.

#### 4.1.1 Standby-Run Switch

The Standby-Run switch controls the power to the amplifier's high-voltage transformers. **Switch to the Run position (right) to energize the amplifier. Switch to the Standby position (left) to remove power from the high-voltage transformers and place the amplifier in Standby mode.**

#### 4.1.2 Run/Standby Indicator

**Run mode:** The indicator will be lit solid green. The amplifier's high-voltage transformers are energized and the unit will amplify the input signal.

**Standby mode:** The indicator will be lit solid amber. The amplifier will be placed in Standby when one of the following conditions occurs:

1. High/Low Line error
2. Overtemp condition
3. Fault condition
4. The user sets the front-panel Standby-Run switch to the Standby (left) position.

In Standby mode, the amplifier's low-voltage transformer is energized but the high-voltage transformers are not.

To release the amplifier from Standby mode:

1. **High/Low Line error:** Clear the over- or under-voltage condition. The amplifier will resume

- operation when the input voltage is brought within the operating range of the amplifier.
2. **Overtemp condition:** Remove the input signal from the amplifier and leave the amplifier with the Standby-Run switch in the Run position and with the fans operating to cool the amplifier. When the amplifier's internal temperature drops to less than 100°C, the amplifier will resume operation.
3. **Fault condition:** Turn the front-panel Standby-Run switch to Standby and then back to Run to reset the amplifier. If the fault condition recurs or does not clear, the amplifier may require servicing. See the **Troubleshooting** section for more information.
4. **Standby-Run switch pressed:** When the amplifier is operating (Run mode), setting the front-panel Standby-Run switch to the Standby position (left) will place the amplifier in Standby mode. Set the switch to Run (right) to release the amplifier from Standby and return the amplifier to Run mode.

#### 4.1.3 Signal/Overload Indicator

**Signal Presence:** When an input signal is presented at an active signal input on the amplifier at a level greater than 0.5V, the Signal/Overload indicator will light solid green.

**Overload (clipping):** The indicator will flash amber intermittently. When the indicator flashes amber, this indicates that the output of the system could not follow the input signal due to voltage or current limits. The amber Overload indicator will begin flashing when distortion is greater than 0.1%.



Figure 4.1 – Front Panel Controls and Indicators

**4.1.4 High/Low Line Indicator**

This amber indicator will illuminate, and the amplifier will be placed in Standby if the detected AC mains voltage is outside of the operable range of the amplifier ( $\pm 10\%$ ). This can occur if the amplifier's back-panel breaker is not in the on position (left), or if the AC supply into the amplifier is higher or lower than the operable range.

To remove the amplifier from Standby, the AC mains must be brought to within the optimal range. Once the fault condition has been cleared, the amplifier will return automatically to Run mode. If the High/Low Line indicator does not turn off or if the amplifier does not return from Standby, the amplifier may require servicing. See the **Troubleshooting** section for more information.

**4.1.5 Overtemp Indicator**

The amplifier monitors the temperature inside the high-voltage transformers and in the output stage heat sinks. The amber Overtemp indicator will light and the amplifier will be placed in Standby mode when the temperature sensors detect a condition that would damage the amplifier. If the Overtemp pulse is extremely short, as in the case of defective wiring or switches, this indicator may be lit too briefly to observe.

To remove the amplifier from Standby and return it to normal operation after an Overtemp fault has occurred, make sure the Standby-Run switch is in the Run position and the amplifier fans are running, and then remove the input signal from the amplifier. Allow the fans to run until the amplifier automatically returns to Run mode. See the

**Troubleshooting** section for information on identifying and correcting the cause of an Overtemp fault condition.

**4.1.6 Fault Indicator**

The red Fault indicator will light and the amplifier will be placed in Standby under two conditions:

1. High frequency oscillation is causing high shoot-through current.
2. An output transistor has shorted, causing the output fault condition.

Cycle the front-panel Standby-Run switch (Standby, then Run) to reset the amplifier. If the fault condition occurs or does not clear, the amplifier may require servicing. See the **Troubleshooting** section for more information.

**4.2 Back-Panel Controls & Connectors**

This section provides an overview of Back-Panel controls and connectors found on the 9100 series amplifier. Please refer to **Figure 4.2** for component locations.

**Configuration DIP Switches** – This set of 12 DIP switches provides various functions and allows the amplifier to be configured for special applications. See the **“Advanced Configuration”** section for more information.

**Unbalanced BNC Input Connector** – This input option provides a standard unbalanced input.

**Current Monitor Connector** – This unbalanced BNC port allows for connection to current monitoring equipment. The current monitor output is  $1V = 20A$ .

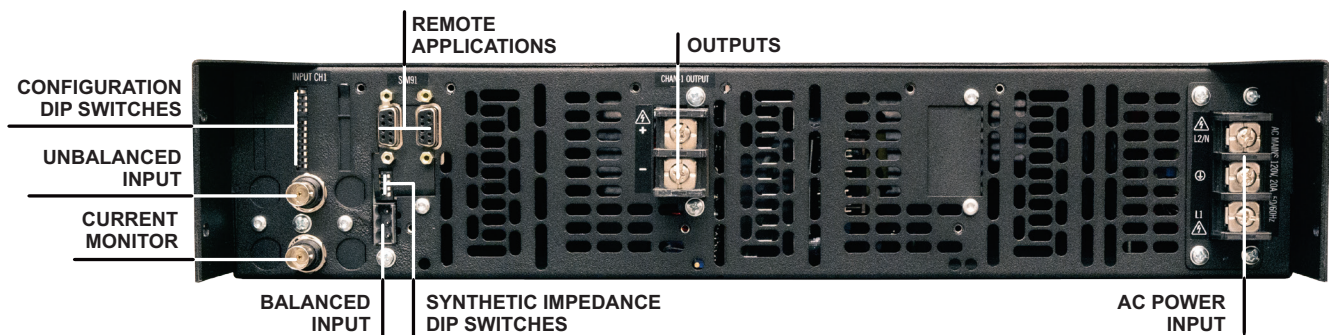

CURRENT MONITOR: 50A = 5V

Figure 4.2 – Back Panel Controls and Connectors

**Balanced WECO Input Connector** – This input option provides a balanced input.

**Remote Connectors** – These two 9-pin D-sub connectors, labeled Interconnect A and Interconnect B, can be used to set up a Safety Interlock circuit to automatically place the amplifier in Standby mode when tripped. See the “**Applications**” section for more information.

**Synthetic Impedance DIP Switches** – This set of

DIP switches allows the amplifier to be configured with one of eight levels of synthetic impedance. See the “**Advanced Configuration**” section for more information.

**Output Terminals** – Connect output lines from the load to this pair of high-current output terminals using #10 spade or ring terminals.

**AC Power Input** – Three-terminal barrier strip connector.

## 5 Advanced Configuration

The 9100 series amplifier was designed to offer exceptional versatility in operation. You can choose from a range of field-configurable options, including:

- Enable DC Servo to ensure DC offset remains at zero and safely drive coils and transformers.
- Select Controlled-Current or Controlled-Voltage modes of operation.
- Select between two compensation networks for Controlled Current operation: CC1, designed for loads from 50  $\mu$ H to 500  $\mu$ H; or CC2, designed for loads from 500  $\mu$ H to 1.5 mH.
- Select DC-coupled or AC-coupled operation.
- Adjust the amplifier gain from 2.5 to 20 in increments of 2.5.
- Limit current output from 15A to 60A in increments of 15A.

- Select and enable a synthetic impedance from 0.125 ohms to 0.875 ohms (**single-channel models only**).

### 5.1 DIP Switch Configurations

The 9100 series amplifier provides 12 DIP switches located on the amplifier back panel. Most configuration settings can be made using these DIP switches. See **Figure 5.1** for default DIP switch settings and descriptions.

Three additional DIP switches used to enable synthetic impedance are provided on the SIM-91 module, which is included on all standard 9100 series amplifiers. See **Figure 5.2** for default DIP switch settings and descriptions for the SIM-91 module.

### 9000 Series Default DIP Switch Settings

Red = Default

	OFF	ON		
1	<input type="checkbox"/>	<input checked="" type="checkbox"/>	1 DC SERVO	OFF ON
2	<input type="checkbox"/>	<input checked="" type="checkbox"/>	2 OPERATION MODE	CC CV
3	<input type="checkbox"/>	<input checked="" type="checkbox"/>	3 COMPENSATION NETWORK 2	OFF ON
4	<input type="checkbox"/>	<input checked="" type="checkbox"/>	4 COMPENSATION NETWORK 1	OFF ON
1	<input checked="" type="checkbox"/>	<input type="checkbox"/>	5 <i>CONTROL CONFIGURATION</i>	FOLLOWER MASTER
2	<input type="checkbox"/>	<input checked="" type="checkbox"/>	6 COUPLING	AC DC
3	<input type="checkbox"/>	<input checked="" type="checkbox"/>	7 GAIN BIT 3 (MSB)	OFF 10
4	<input type="checkbox"/>	<input checked="" type="checkbox"/>	8 GAIN BIT 2	OFF 5
5	<input type="checkbox"/>	<input checked="" type="checkbox"/>	9 GAIN BIT 1 (LSB)	OFF 2.5
6	<input checked="" type="checkbox"/>	<input type="checkbox"/>	10 <i>ELECTRONIC GAIN MATCHING</i>	OFF ON
7	<input type="checkbox"/>	<input checked="" type="checkbox"/>	11 CURRENT LIMIT BIT 2 (MSB)	OFF +30A
8	<input type="checkbox"/>	<input checked="" type="checkbox"/>	12 CURRENT LIMIT BIT 1 (LSB)	OFF +15A

NOTE: *GRAY TEXT INDICATES SWITCH USED FOR FACTORY CONFIGURATION ONLY.*  
 ALL BIT SWITCHES ARE ADDITIVE. RIGHT = ON.

Figure 5.1 – Default DIP Switch Settings and Descriptions

### SIM-91 Default DIP Switch Settings (Single-Channel Models Only)

Red = Default

	OFF	ON		
1	<input type="checkbox"/>	<input checked="" type="checkbox"/>	1 SYNTHETIC IMPEDANCE BIT 3 (MSB)	OFF 0.5 $\Omega$
2	<input type="checkbox"/>	<input checked="" type="checkbox"/>	2 SYNTHETIC IMPEDANCE BIT 2	OFF 0.25 $\Omega$
3	<input type="checkbox"/>	<input checked="" type="checkbox"/>	3 SYNTHETIC IMPEDANCE BIT 1 (LSB)	OFF 0.125 $\Omega$
4	<input type="checkbox"/>	<input checked="" type="checkbox"/>	4 UNUSED	OFF -----

NOTE: ALL BIT SWITCHES ARE ADDITIVE. RIGHT = ON.

Figure 5.2 – SIM-91 Default DIP Switch Settings and Descriptions

### SW#1: DC Servo

The DC Servo function ensures that no DC offset is present at the signal output (-3 dB at 3 Hz). Select DC Servo when driving transformers or other coils. When the DC Servo DIP switch is in the RIGHT position, the DC Servo function is enabled. When this switch is in the LEFT position (default), the DC Servo function is disabled.

### SW#2: Operation Mode

When the Operation Mode DIP switch is in the RIGHT position (default), the amplifier will operate in Controlled-Voltage mode, and the amplifier's output voltage will be controlled by its input voltage signal. When this switch is in the LEFT position, the amplifier will operate in Controlled-Current mode, and the amplifier's output current will be controlled by its input voltage signal.

**IMPORTANT:** Controlled-Current operation requires the use of a compensation network. The 9100 series amplifier provides two installed compensation networks: one suitable for loads from 50  $\mu$ H to 500  $\mu$ H; the other suitable for loads from 500  $\mu$ H to 1.5 mH. For more information on Controlled-Current operation, including instructions for selecting the best compensation option for your application, see the topic "Controlled Current Operation" in the *Applications* section of this manual. If neither of the available RC networks is suitable for your application, please contact **AE Techron Technical Support**.



## CAUTION

Do not change the setting of the Operation Mode switch while the amplifier is operating (Run mode). Damage to the amplifier or the load can occur. Place the amplifier in Standby mode by pressing the front-panel Standby-Run switch before changing the Operation Mode setting.

### SW#3: Compensation Network 2

When the 9100 series amplifier is used in Controlled-Current mode, the current control loop is tuned with an RC network. The factory default network (Compensation Network 1) provides



## CAUTION

In Controlled-Current Mode, the load is part of the amplifier circuit, and the relationship of the load to the amplifier is critical. For proper and safe operation in Controlled-Current mode, you must observe the following guidelines:

1. **Properly attach a load before operating the amplifier.**
2. **DO NOT use a blocking capacitor.** The load must have a DC path.
3. **Never leave the load open.** If you feel the load must be fused, which could lead to a potential open circuit, please contact AE Techron Technical Support.
4. **Check to make sure the load has some inductive component.**
5. **Provide appropriate Compensation for the load, using either Compensation Network 1 (SW#4) or Compensation Network 2 (SW#3).** If neither compensation network is adequate for your load, contact **AE Techron Technical Support**.
6. **Turn off the amplifier immediately if oscillation occurs.**

**Failure to follow these guidelines may result in damage to the amplifier or load.**

100k ohm resistance and 2.2 nF capacitance and should be used with loads that are 50  $\mu$ H to 500  $\mu$ H. If this default network is not adequate for your application and load, the Compensation Network 1 switch can be turned off and the Compensation Network 2 switch can be used to enable a network that provides 100k ohm resistance and 10 nF capacitance and should be used with loads that are 500  $\mu$ H to 1.5 mH.

**NOTE:** It is recommended to only use one of the compensation networks at a time. Having SW#3 and SW#4 both on (RIGHT) will likely provide improper compensation for the load, and may result in amplifier instability.

For more information on Controlled-Current operation, including instructions for selecting the best compensation setting for your application, see the topic "Controlled Current Operation" in the *Applications* section of this manual. If neither of the available RC networks is suitable for your application, please contact **AE Techron Technical Support**.

### SW#4: Compensation Network 1

When the 9100 series amplifier is used in Controlled-Current mode, the current control loop is

tuned with an RC network. The Compensation Network 1 switch enables the factory default RC network. This provides 100k ohm resistance and 2.2 nF capacitance and should be used with loads that are 50  $\mu$ H to 500  $\mu$ H. If this default network is not adequate for your application and load, the Compensation Network 1 switch can be turned off and the Compensation Network 2 switch can be used to enable a network that provides 100k ohm resistance and 10 nF capacitance and should be used with loads that are 500  $\mu$ H to 1.5 mH.

**NOTE:** It is recommended to only use one of the compensation networks at a time. Having SW#3 and SW#4 both on (RIGHT) will likely provide improper compensation for the load, and may result in amplifier instability.

For more information on Controlled-Current operation, including instructions for selecting the best compensation option for your application, see the topic “Controlled Current Operation” in the **Applications** section of this manual. If neither of the available RC networks is suitable for your application, please contact **AE Techron Technical Support**.

#### SW#5: Control Configuration

*Used for factory configuration only.*

#### SW#6: Coupling

When the Coupling DIP switch is in the RIGHT position (default), the amplifier can receive and amplify both DC and AC signal. When this switch is in the LEFT position, a 30-Hz high-pass filter on the inputs prevents the transmission of DC signal.

#### SW#7 – SW#9: Gain

The amplifier gain can be adjusted from 2.5 to 20 in increments of 2.5 using switches 7 through 9. All switches are additive and provide the following values toward the total Gain amount: SW#7 = 10.0, SW#8 = 5.0, SW#9 = 2.5. Refer to **Figure 5.3** for all available gain switch settings.

#### SW#10: Electronic Gain Matching

*Used for factory configuration only.*

ON = DIP Switch RIGHT OFF = DIP Switch LEFT			
SW#7	SW#8	SW#9	Gain
ON	ON	ON	20.0
ON	ON	OFF	17.5
ON	OFF	ON	15.0
ON	OFF	OFF	12.5
OFF	ON	ON	10.0
OFF	ON	OFF	7.5
OFF	OFF	ON	5.0
OFF	OFF	OFF	2.5

Figure 5.3 – Gain Switch Configurations

#### SW#11 - #12: Current Limit

These two switches control the current-limit settings for the amplifier. When both switches are in the RIGHT position (default), the amplifier's output current is limited to 60A. The current-limit can be lowered in 15A increments by setting one or more of the current limit switches in the LEFT position. Refer to **Figure 5.4** for all available current-limit switch settings.

ON = DIP Switch RIGHT OFF = DIP Switch LEFT		
SW#11	SW#12	Current Limit
ON	ON	60A
ON	OFF	45A
OFF	ON	30A
OFF	OFF	15A

Figure 5.4 – Current Limit Switch Configurations

#### 5.1.1 SIM-91 Module DIP Switches

This set of DIP switches allows the amplifier to be configured with one of eight levels of synthetic impedance.

#### SW#1 - SW#3: Synthetic Impedance

**NOTE SW#4 is unused.**

These three switches allow the addition of a synthetic impedance on the output of the amplifier. Synthetic Impedance can be used to increase stability when driving capacitive loads. It can also be used in testing where the effect of long power lines needs to be simulated (such as for power utility applications).

When all three switches are in the LEFT position (default), Synthetic Impedance is disabled. The

ON = DIP Switch RIGHT OFF = DIP Switch LEFT			
SW#1	SW#2	SW#3	Synthetic Impedance
ON	ON	ON	0.875Ω
ON	ON	OFF	0.750Ω
ON	OFF	ON	0.625Ω
ON	OFF	OFF	0.500Ω
OFF	ON	ON	0.375Ω
OFF	ON	OFF	0.250Ω
OFF	OFF	ON	0.125Ω
OFF	OFF	OFF	0.00Ω

Figure 5.5 – Synthetic Impedance Switch Configurations

synthetic impedance can be added in increments of 0.125 ohms by setting one or more of the synthetic impedance switches in the RIGHT position. Refer to **Figure 5.5** for all available synthetic impedance switch settings.

## 5.2 Custom Compensation

If you wish to change one of the two standard compensations to a custom compensation, please contact **AE Techron Technical Support** for specific instructions.



## 6 Applications

### 6.1 Emergency Standby Switch or Safety Interlock

The two 9-pin D-Sub connectors on the amplifier back-panel SIM-91 module labeled **Interlock A** and **Interlock B** can be used to remotely place the amplifier in Standby mode. This can provide a valuable safety feature, such as in creating a safety interlock for a cabinet in which one or more 9100-series amplifiers are installed or wiring an emergency stop switch to the cabinet front or another accessible location.

The Remote Standby functions the same as the amplifier's front-panel Standby-Run switch by placing the amplifier in Standby mode. When a 9100 series amplifier is in Standby mode, the low-voltage transformer is energized but the high-voltage transformers are not. By using a Remote Standby switch, all amplifiers in a multi-amp system can quickly and reliably be placed in Standby mode simultaneously. A Remote Standby switch also eliminates mechanical wear on the amplifier's front-panel Standby-Run switch.

To use this function, wire a switch using Pin 1 (Interlock) and either Pin 3 or Pin 6 (Ground), as shown in **Figure 6.1**. Note that either the Interlock A connector or the Interlock B connector can be used.

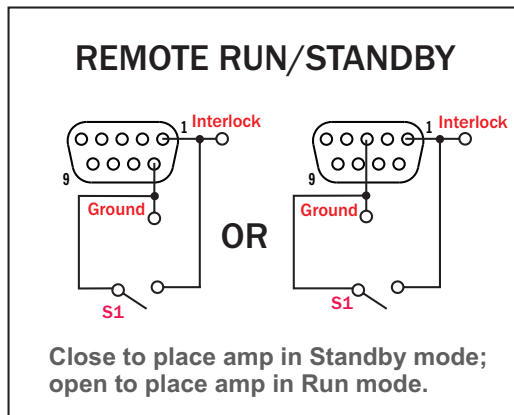

Figure 6.1 – Using the Interlock A or Interlock B connector to wire a safety interlock switch

### 6.2 Controlled-Voltage vs. Controlled-Current Modes of Operation

AE Techron 9100 series amplifiers can be field-configured to operate as **Voltage Amplifiers** (Voltage-Controlled Voltage Source) or as **Transconductance Amplifiers** (Voltage-Controlled Current Source). The mode selection is made via the back-panel DIP switch #2. See the **Advanced Configuration** section for more information.

When configured as a **Controlled-Voltage** source (voltage amplifier), the amplifier will provide an output voltage that is constant and proportional to the control (input) voltage. If the load's impedance changes, the amplifier will seek to maintain this ratio of input to output voltage by increasing or decreasing the current it produces, as long as it is within the amplifier's ability to create the required current. Use this mode if you want the output voltage waveform to be like the input waveform (see **Figure 6.2**).

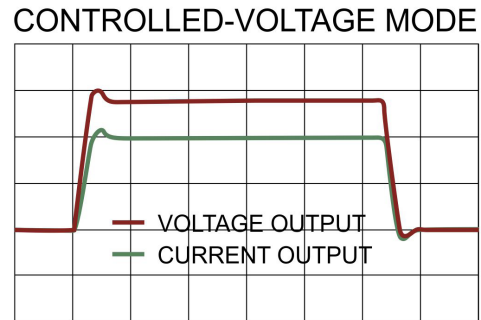

Figure 6.2 – Input to Output Comparison, Controlled-Voltage Operation

Conversely, when configured as a **Controlled-Current** source (transconductance amplifier), the amplifier will provide an output current that is constant and proportional to the control (input) voltage. If the load's impedance changes, the amplifier will seek to maintain this transconductance (ratio of input voltage to output current) by increasing or decreasing the voltage it produces, as long as it is within the amplifier's ability to create the required voltage. Use this mode if you want the output current waveform to be like the input waveform (see **Figure 6.3**).

**CONTROLLED-CURRENT MODE**

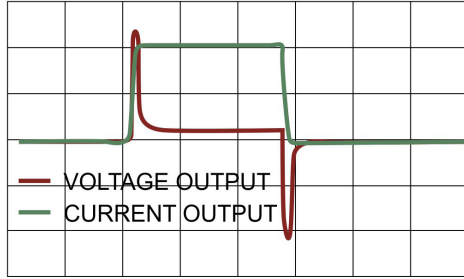

Figure 3.3 – Input to Output Comparison, Controlled-Current Operation

**6.2.1 Safety and Operation Considerations for Controlled Current Operation**

When an AE Techron amplifier is configured as a Controlled-Current source, care needs to be exercised in its operation. **Any voltage controlled current source should never be turned on without a load, (with some impedance, real or effective) connected to its output terminals.**

When asked to operate in this way, any current source (including an AE Techron amplifier) will increase its output voltage in an attempt to drive the requested current into the load. In an open-circuit condition, creating current flow will be impossible. The current source will increase its output voltage until it reaches its voltage limit. This is a potentially dangerous condition for both the AE Techron amplifier and for any user who might come in contact with the amplifier output terminals.

Likewise, operation in Controlled Current mode into a load that is completely resistive is **NOT recommended**. The load must have some inductance for Controlled Current mode to operate correctly.

When operating in Controlled-Current (CC) mode, a compensation circuit is required to ensure accurate output current. Since the load is a critical circuit component in CC mode, the inductive and resistive values of the load will determine the required compensation values.

One of the two compensation settings that can be enabled with DIP switch settings will be sufficient for most applications. If you determine that neither Compensation Network 1 or Compensation Network 2 will be adequate for your application and load, please contact **AE Techron Technical Support** for additional compensation options.

The following section describes methods for determining proper compensation setting for your application when operating in Controlled-Current mode.

**6.2.2 Selecting Compensation for CC Operation**

AE Techron 9000 series amplifiers can be configured for either Controlled Voltage (CV) or Controlled Current (CC) mode of operation. When operating the amplifier in Controlled Voltage (CV) mode, compensation is not required. However, when operating in Controlled Current (CC) mode, the amplifier load becomes an integral part of the system. In order to ensure system stability and to control available bandwidth, compensation via an RC network is required for CC operation. The following steps will show you how to determine the proper compensation network for your load to allow you to operate your amplifier in CC mode safely and effectively.

**STEP 1: Check Amplifier Operation in CV mode.**

We recommend that you power-up and enable the amplifier in Controlled Voltage mode without attaching a load before configuring your amplifier for Controlled Current operation. This will allow you to verify that the input signal and the amplifier are operating correctly.

Once this initial check is completed, power down the amplifier, attach your load, and move the back-panel Operation Mode DIP switch (SW#2) to the RIGHT position to place the amplifier in CC mode.

**STEP 2: Determine Required Compensation.**

When operating an amplifier in Controlled-Current mode, the load becomes an integral part of the system. In order to determine the required compensation for your load, consulting the following table to determine the approximate compensation capacitance (CC) required based on the inductance of your load. Note that these calculations are based on empirical measurements and are approximate.

**NOTE: Load Resistance (R) is assumed to be <5 ohms.**

Load Inductance (L)	Compensation Capacitance (CC)	Compensation Network
75 $\mu$ H to 1 mH	0.0022 $\mu$ F	Network 1
1 mH to 5 mH	0.0100 $\mu$ F	Network 2

**STEP 3: Enable Compensation Network**

If your load inductance is between 75  $\mu$ H and 1 mH, and your load resistance is less than 5 ohms, then you can likely use Compensation Network 1 for your application. If your load inductance is between 1 mH and 5 mH, and your load resistance is less than 5 ohms, then you can likely use Compensation Network 2 for your application. (See **Figure 7.4**). These compensation networks

are enabled when Compensation Network 1 DIP switch (SW#6) or Compensation Network 2 DIP switch (SW#5) on the Master amplifier module is set to the ON (LEFT) position.

If your load inductance falls outside of these ranges, or if your load resistance is greater than 5 ohms, please contact **AE Techron Technical Support** for assistance.

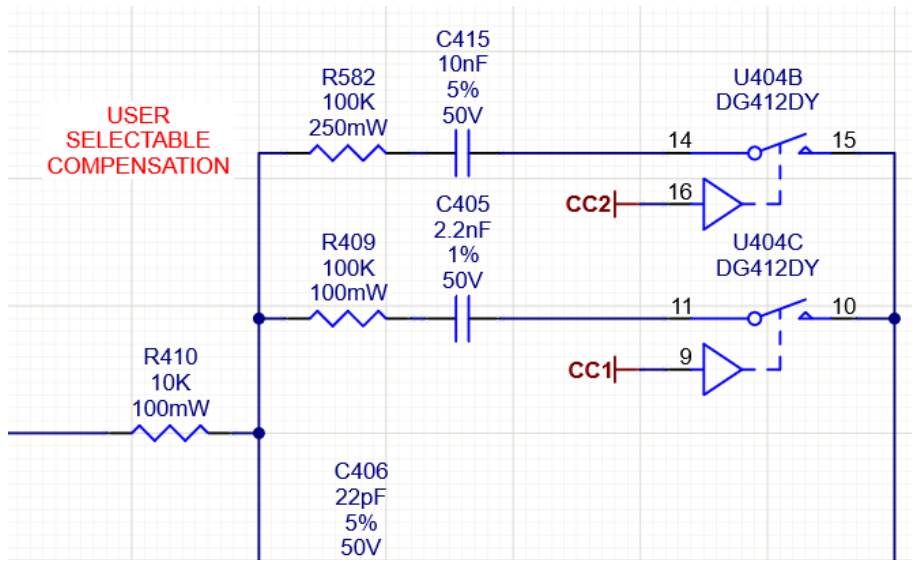

Figure 7.4 – Selectable factory-installed compensation networks

**STEP 4: Verifying Operation**

**Remember the load you are connecting is a part of the system and the amplifier should not be turned on without the load being connected.**

After selecting and enabling your choice of Compensation Network, check to ensure that the Operation Mode DIP switch is set to CC (RIGHT), then power up the amplifier without signal input.

To begin testing, input a square wave with a frequency of 100 Hz to 1 kHz, or a squared pulse at a low level (typically 0.25 to 2.0 volts). A limited-rise-time, repetitive pulse of low duty cycle is preferred.

Observe the output current through a current monitor or current probe. Look for clean transition edges. The presence of ringing or rounding on the

transition edges indicates compensation problems. (See **Figure 7.5.**)

If a change in compensation is necessary, please contact **AE Techron Technical Support** for assistance. **DO NOT** operate your amplifier in Controlled Current mode without proper compensation.

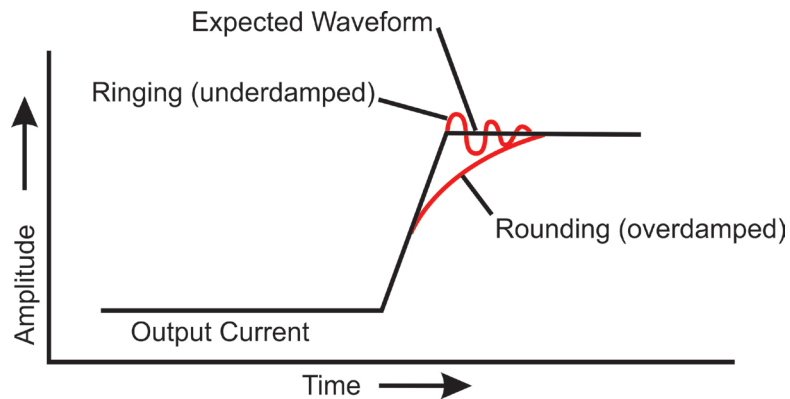

Figure 7.5 – Compensation Effects on Waveform

### 6.3 Driving Reactive Loads

Like all switching amplifiers, 9000 series amplifiers are able to reuse the energy returned from reactive loads. Unlike purely resistive loads, loads with some reactance (either capacitive or inductive) will store energy during part of a cycle, and then release some of this energy back later. This

energy is transferred back to the load through the amplifier's power supply. This allow the amplifier to deliver continuous apparent power that is up to five times the rated power of the amplifier when driving reactive loads.

## 7 Maintenance

Simple maintenance can be performed by the user to help keep the equipment operational. The following routine maintenance is designed to prevent problems before they occur. See the **Troubleshooting** section, for recommendations for restoring the equipment to operation after an error condition has occurred.

Preventative maintenance is recommended after the first 250 hours of operation, and every three months or 250 hours thereafter. If the equipment environment is dirty or dusty, preventative maintenance should be performed more frequently.

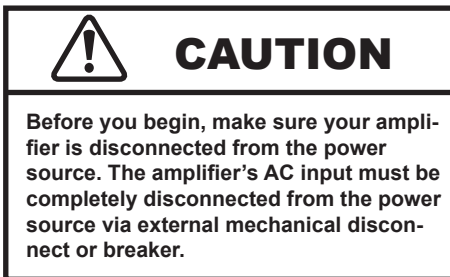

### 7.1 Clean Amplifier Filter and Grills

#### 7.1.1 Tools Required

The recommended equipment and supplies needed to perform the functions required for this task are described as follows.

- Vacuum cleaner
- Damp cloth (use water only or a mild soap diluted in water)

To ensure adequate cooling and maximum efficiency of the internal cooling fans, the amplifier's front and rear grills should be cleaned periodically. To clean the amplifier grills and filter, complete the following steps:

1. Disconnect the amplifier from its power source via external mechanical disconnect or breaker.
2. The front grill is secured to the amplifier front panel by magnets. Pull out on the grill to release it from the front panel.
3. Remove the filter located behind the front grill.
4. Using a vacuum cleaner, vacuum the front ventilation grill, the grill filter, and the back ventilation exit grill.
5. Using a damp cloth, clean the amplifier front panel and the rear ventilation grills. Also use the damp cloth to clean the front grill and filter. If necessary, these can be immersed in warm, soapy water.
6. Dry the front panel, filter, and grills with a clean cloth or allow to air dry. **IMPORTANT: All parts should be completely dry before reconnecting or restarting the amplifier.**
7. Reinstall the filter and replace the amplifier front grill.



## 8 Troubleshooting

### 8.1 Introduction & Precautions

This section provides a set of procedures for identifying and correcting problems with the 9100 series amplifier. Rather than providing an exhaustive and detailed list of troubleshooting specifications, this section aims to provide a set of short-cuts intended to get an inoperative amplifier back in service as quickly as possible.

The procedures outlined in this section are directed toward an experienced electronic technician; it assumes that the technician has knowledge of typical electronic repair and test procedures.

### 8.2 No Signal

Missing output signal may be caused by one of the following:

1. The Control Configuration DIP switch (#5) is set to the Follower (LEFT) position. The default setting for this switch is Master (RIGHT) and this setting should only be changed at the AE Techron. Return the switch setting to Master (RIGHT) to restore the signal path.
2. A signal source is not connected to the BNC input connector (or the WECO connector on single-channel models). See the **Amplifier Setup** section in this manual for more information on how to correctly connect to a signal source.

### 8.3 No LEDs Illuminated

If none of the LEDs on the Display Panel are illuminated, check the following:

1. The AC mains are not connected or not on (see the **Amplifier Setup** section for more information).

### 8.4 Over/Under Line LED Lit

The amplifier will protect itself from AC mains voltage that is 10% above or below the voltage indicated on the back panel. This can occur if the AC supply into the amplifier is higher or lower than the operable range.

Check the voltage level of the AC supply. If the AC mains voltage is more than 10% outside the range of the operating voltage, increase or reduce the AC mains voltage to the proper level. When the line voltage condition is corrected, the amplifier will automatically return to Run mode. If the amplifier does not reset, the amplifier's internal transformers may need to be replaced. Please see the **Factory Service** information at the end of this section.

### 8.5 Run/Standby LED Remains Amber

When the Run/Standby LED is lit solid amber, the amplifier is in Standby mode. Press the front-panel Standby-Run switch to the Run position to place the amplifier in Run mode.

If the amplifier does not return to run mode, check to see if the High/Low Line, Overtemp, or Fault LEDs are lit, and then follow the instructions in this section for remedying the fault condition and returning the amplifier to Run mode.

If the remedies given fail to restart the amplifier, the amplifier may require servicing. See the Factory Service Information at the end of this section.

### 8.6 Amplifier Overheats (Over Temp Fault Condition)

There are two possible reasons why the 9100 series amplifier is overheating: Excessive power requirements or inadequate airflow.

#### 8.6.1 Excessive Power Requirements

An amplifier will overheat if the required power exceeds the amplifier's capabilities. High duty cycles and low-impedance loads are especially prone to cause overheating. To see if excess power requirements are causing overheating, check the following:

1. The application's power requirements fall within the specifications of the amplifier. See the amplifier's Datasheet to verify operating parameters.
2. Faulty output connections and load.
3. Undesired DC offset at the Output and Input signal.

If the amplifier chronically overheats with suitable power/load conditions, then the amplifier may not be receiving adequate airflow. To check for adequate airflow, proceed with the following steps:

### 8.6.2 Check for Inadequate Airflow

1. Check air filters. Over time they can become dirty and worn out. It is a good idea to clean the air filters periodically with a mild detergent and water.
2. Visually inspect fans to assure correct operation while amplifier is On (I). Any inoperative, visibly slow, or reverse-spinning fan should be replaced. Please see the Factory Service information at the end of this section.

An OverTemp condition places the amplifier in Standby mode. If the OverTemp pulse is extremely short, as in the case of defective wiring or switches, the OverTemp pulse may be too brief to observe.

### 8.6.3 Resetting After OverTemp

To reset the amplifier after an OverTemp has occurred, make sure fans are running. Remove the input signal from the amplifier and allow the fans to run until the amplifier has cooled sufficiently and the amplifier automatically returns to Run mode.

**NOTE:** Typically, overheating that occurs in the amplifier outputs due to inadequate airflow or very low impedance loads will clear within 5 minutes. Overheating in the amplifier transformers due to excessive power requirements will take from 5 to 15 minutes to clear. Timing the cool-down period for the amplifier may help to determine the cause of the overheating.

If the fault condition does not clear, return the amplifier for Factory Service.

## 8.7 Fault LED is Illuminated

The 9100 series amplifier contains protection circuitry that disables the amplifier if an output stage is behaving abnormally. This usually indicates an output transistor has shorted.

To clear the Fault condition, follow these steps:

1. Turn off the signal source.

2. Turn off the AC mains.
3. Turn AC mains power back on. If the Fault LED doesn't illuminate again, press the Standby-Run switch to place the amplifier in Run mode and turn the signal source on.
4. If the Fault LED is still illuminated and the Fault condition doesn't clear, return the amplifier for Factory Service. See the Factory Service information at the end of this section.

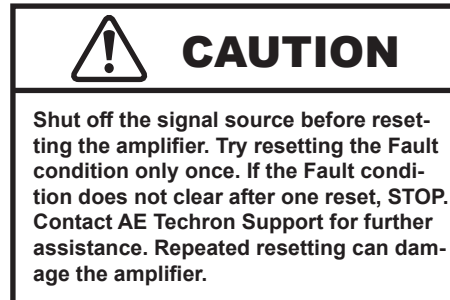

## 8.8 Factory Service

If the troubleshooting procedures are unsuccessful, the amplifier may need to be returned for Factory Service. All units under warranty will be serviced free of charge (customer is responsible for one-way shipping charges as well as any custom fees, duties, and/or taxes). Please review the Warranty at the beginning of this manual for more information.

All service units must be given Return Authorization by AE Techron, Inc. before being returned. Return Authorizations can be requested on our website or by contacting our Customer Service Department.

Please take extra care when packaging your amplifier for repair. It should be returned in its original packaging or a suitable alternative. Replacement packaging materials can be purchased for a nominal fee.

Please send all service units to the following address and be sure to include your Return Authorization Number on the box.

**AE Techron, Inc.**  
**Attn: Service Department / RMA#**  
**2507 Warren Street**  
**Elkhart, IN 46516**