

AETECHRON



7234

Operator's Manual

Single-Channel Industrial Amplifier for Demanding, High-Power Systems

DECLARATION OF CONFORMITY

Technical Construction File Route

Issued By: AE Techron, Inc.
2507 Warren Street
Elkhart, IN 46516

For Compliance Questions Only: Larry Shank
574-295-9495
lshank@aetechron.com

This Declaration of Conformity is issued under the sole responsibility of AE Techron, Inc., and belongs to the following product:

Equipment Type: Industrial Power Amplifiers

Model Name: 7234

EMC Standards:

- EN 61326-1: 2013 – Electrical Equipment for Measurement, Control and Laboratory use
— EMC Requirements
- EN 55011: 2009 + A1: 2010 – Industrial, Scientific and Medical (ISM) radio-frequency equipment
— Radio disturbance characteristics
— Limits and methods of measurement
- EN 61000-4-2: 2009 – Electromagnetic compatibility (EMC) Part 4: Testing and measurement techniques:
Electrostatic discharge immunity test
- EN 61000-4-3: 2006 + A2: 2010 – Electromagnetic compatibility (EMC) Part 4: Testing and measurement techniques:
Radiated radio-frequency electromagnetic field immunity test
- EN 61000-4-4: 2012 – Electromagnetic compatibility (EMC) Part 4: Testing and measurement techniques:
Electrical fast transient/burst immunity test
- EN 61000-4-5: 2006 – Electromagnetic compatibility (EMC) Part 4: Testing and measurement techniques:
Surge immunity test
- EN 61000-4-6: 2009 – Electromagnetic compatibility (EMC) Part 4: Testing and measurement techniques:
Immunity to conducted disturbances induced by radio frequency field
- EN 61000-4-8: 2010 – Electromagnetic compatibility (EMC) Part 4: Testing and measurement techniques:
Power frequency magnetic field immunity test
- EN 61000-4-11: 2004 – Electromagnetic compatibility (EMC) Part 4: Testing and measurement techniques:
Voltage dips, short interruptions and voltage variations immunity test

Safety Standard:

BSEN61010-1:2010 (inc Corr. May 2011) – Safety requirements for electrical equipment for measurement, control, and laboratory use

I certify that the product identified above conforms to the requirements of the EMC Council Directive 2014/30/E, and the Low Voltage Directive 2014/35/EU.

Signed:



Larry Shank
President

Place of Issue: Elkhart, IN, USA
Date of Issue: August 3, 2021

CE Affixing Date: August 2, 2021

Three-Year, No-Fault Warranty

SUMMARY OF WARRANTY

AE TECHRON INC., of Elkhart, Indiana (Warrantor) warrants to you, the ORIGINAL COMMERCIAL PURCHASER and ANY SUBSEQUENT OWNER of each NEW **AE TECHRON INC. product**, for a period of three (3) years from the date of purchase, by the original purchaser (warranty period) that the product is free of defects in materials and workmanship and will meet or exceed all advertised specifications for such a product. We further warrant the new AE Techron product regardless of the reason for failure, except as excluded in the Warranty.

ITEMS EXCLUDED FROM WARRANTY

This AE Techron Warranty is in effect only for failure of a new AE Techron product which occurred within the Warranty Period. It does not cover any product which has been damaged because of any intentional misuse, or loss which is covered under any of your insurance contracts. This warranty does not extend to any product on which the serial number has been defaced, altered, or removed. It does not cover damage to loads or any other products or accessories resulting from **AE TECHRON INC.** product failure. It does not cover defects or damage caused by the use of unauthorized modifications, accessories, parts, or service.

WHAT WE WILL DO

We will remedy any defect, regardless of the reason for failure (except as excluded), by repair or replacement, at our sole discretion. Warranty work can only be performed at our authorized service centers or at our factory.

Expenses in remedying the defect will be borne by **AE TECHRON INC.**, including one-way surface freight shipping costs within the United States. (Purchaser must bear the expense of shipping the product between any foreign country and the port of entry in the United States and all taxes, duties, and other customs fees for such foreign shipments.)

HOW TO OBTAIN WARRANTY SERVICE

When you notify us or one of our authorized service centers of your need for warranty service, you will receive an authorization to return the product for service. All components must be shipped in a factory pack or equivalent which, if needed, may be obtained

from us for a nominal charge. We will take corrective actions and return the product to you within three weeks of the date of receipt of the defective product, or will make available to you a product of equal or better performance on temporary loan until your product can be repaired or replaced and returned to you. If the repairs made by us are not satisfactory, notify us immediately.

DISCLAIMER OF CONSEQUENTIAL AND INCIDENTAL DAMAGES

You are not entitled to recover from us any consequential or incidental damages resulting from any defect in our product. This includes any damage to another product or products resulting from such a defect.

WARRANTY ALTERATIONS

No person has the authority to enlarge, amend, or modify this warranty. The warranty is not extended by the length of time for which you are deprived of the use of this product. Repairs and replacement parts provided under the terms of this warranty shall carry only the unexpired portion of this warranty.

DESIGN CHANGES

We reserve the right to change the design of any product from time to time without notice and with no obligation to make corresponding changes in products previously manufactured.

LEGAL REMEDIES OF PURCHASER

There is no warranty that extends beyond the terms hereof. This written warranty is given in lieu of any oral or implied warranties not contained herein. We disclaim all implied warranties, including, without limitation, any warranties of merchantability or fitness for a particular purpose. No action to enforce this Warranty shall be commenced later than ninety (90) days after expiration of the warranty period. This statement of warranty supersedes any others contained in this manual for AE Techron products.

AE TECHRON INC.

Customer Service Department

2507 Warren St. Elkhart, IN, 46516, U.S.A.

(574) 295-9495

www.aetechron.com

Contents

1	Introduction	5
1.1	Features	5
1.2	Configuration Options.....	5
2	Amplifier Unpacking and Installation	6
2.1	Safety First	6
2.2	Unpacking	6
2.3	Installation	6
3	Connections and Startup	7
3.1	Other Operation Modes and Configurations.....	7
3.2	Connecting the Load	7
3.3	Connecting the Input Signal	8
3.4	Other Back Panel Controls and Connectors	9
3.5	Connecting the AC Supply	9
3.6	Start-up Procedure	9
4	Amplifier Operation	10
4.1	Front-Panel Controls	10
4.2	Front-Panel Indicators.....	11
4.3	Back-Panel Controls and Connectors.....	14
5	Advanced Configuration.....	15
5.1	DIP Switch Configurations.....	15
5.2	Internal Configurations	16
6	Applications.....	23
6.1	Remote Status and Control using the Interconnect Ports	23
6.2	Remote Status and Control using the SIM Interlock I/O Connector	25
6.3	Controlled Current Operation	30
6.4	Multi-amp Systems for Increased Voltage or Current.....	35
7	Maintenance	48
7.1	Clean Amplifier Filter and Grills	48
8	Troubleshooting	49
8.1	Introduction & Precautions	49
8.2	Visual Inspection	49
8.3	No Signal.....	49
8.4	No LEDs Illuminated.....	49
8.5	OverVoltage LED Lit.....	49
8.6	Standby and Stop LEDs Remain Illuminated	50
8.7	Standby LED Remains Illuminated.....	50
8.8	Amplifier Overheats (Over Temp Fault Condition).....	50
8.9	Fault LED is Illuminated	50
8.10	Factory Service	51
	Appendix A: Alternate Interconnect Ports Application Wiring	52



Figure 1.1 – 7234 Front Panel

1 Introduction

Congratulations on your purchase of the 7234 power amplifier. AE Techron’s 7234 amplifier is a capable, versatile, and reliable EMC lab partner.

This powerful amplifier/battery simulator provides up to 28A of long-term DC current with surges of up to 50A and can slew voltages at rates of 100+V/μs.

It is load-tolerant, able to drive most inductive, capacitive, and resistive loads easily. The feature set of the 7234 allows it to meet or exceed the requirements of 1000+ Automotive and Aviation DC Conducted Susceptibility Standards Tests.

The 7234 is light enough to be hand-carried from one test location to another, rugged enough to tolerate being bounced around on a cart, and able to be powered from standard 120V/230V AC wall power. These features, along with the 7234’s powerful performance, make it possible to turn virtually any bench or desk into a competent test location.

1.1 Features

The 7234 is a single-channel linear amplifier designed for use in demanding applications requiring very low noise, low distortion, and accurate power amplification from DC to 1 MHz. It features:

- Drop outs and surges as fast as 1.2μs.
- Source and sink (4-quadrant).
- Small signal response up to 1 MHz.
- 13.5 VDC at up to 28A.
- Rugged design.
- Field-selectable ±40V, 75V or 150V potential.
- Protection circuitry protects the AE Techron 7234 from input overloads, improper output connection (including shorted and improper

Performance Overview	
Small Signal Bandwidth (3V p-p)	DC - 1 MHz
Max Continuous Power, 20 kHz	900 watts RMS
For High-Power Applications to:	150 kHz
DC Power:	28A at 13.5 VDC
40 ms Pulse (0.5Ω):	50 Ap
Slew Rate	100+V/μs
Output Voltage:	±150 Vp
Output Impedance:	4.4 mΩ in series with 0.43 μH

- loads), over-temperature, over-current, and supply voltages that are too high or low.
- Ground loop and circulating current protection includes a protection circuit that temporarily forces the amplifier to Standby.

1.2 Configuration Options

The 7234 can be easily configured in the field using back-panel DIP switches or remote contact closure. Configuration options include:

- DC Block enable/disable
- Switch from gain of 20 to gain of 6
- Enable 50 kHz low-pass filter
- Change from controlled-voltage to controlled-current operation
- Parallel operation
- Push/Pull operation
- Series operation

CE 230V versions of this product bear the CE mark

2 Amplifier Unpacking and Installation

The 7234 amplifier is a precision instrument that can be dangerous if not handled properly. Lethal voltages are present in both the AC input supply and the output of the amplifier. For this reason, safety should be your primary concern when you setup and operate this amplifier.

2.1 Safety First

Throughout this manual special emphasis is placed on good safety practices. The following graphics are used to highlight certain topics that require extra precaution.

	<h3>DANGER</h3>
<p>DANGER represents the most severe hazard alert. Extreme bodily harm or death will occur if these guidelines are not followed. Note the explanation of the hazard and instruction for avoiding it.</p>	
	<h3>WARNING</h3>
<p>WARNING alerts you to hazards that could result in severe injury or death. Note the explanation of the hazard and the instructions for avoiding it.</p>	
	<h3>CAUTION</h3>
<p>CAUTION indicates hazards that could result in potential injury or equipment or property damage. Once again, note the explanation of the hazard and the instructions for avoiding it.</p>	

2.2 Unpacking

All amplifiers are tested and inspected for damage before leaving the factory. Carefully unpack and inspect the amplifier for damage. **Please note any damage for future reference and notify the shipping company immediately if damage is found.** Also, please save the shipping carton and materials as evidence of damage and/or for returning the amplifier for repair.

Along with any additional accessories purchased by the customer, all 7234 amplifiers ship with the following:

- 7234 Amplifier
- Power Cord
- 7234 Operator's Manual and Quick Start sheet

2.3 Installation

The 7234 amplifiers are packaged in a rugged powder-coated steel chassis. This chassis is 2U (rack units) tall, and has rack "ears" on each side of the front panel for mounting to a standard EIA (Electronic Industries Association) rack. Use standard rack mounting hardware to mount the amplifier. Use nylon washers if you wish to protect the powder-coat finish on the front of the amplifier.

Optionally, the amplifier can be placed on a bench top; please keep in mind that the protective powder-coating can be scratched when placed on other equipment or on a bench top, especially when there is dirt present. To protect the finish, a set of rubber feet is included in the toolkit that can be installed on the bottom of the amplifier.

Allow ample space on the sides and especially the back of the amplifier for heated air to escape. The amplifier should be mounted in a rack that is adequately ventilated and not sealed. Likewise, the front of the amplifier should be unobstructed to allow cool air to enter the amplifier.



	<h3>CAUTION</h3>
<p>Do not operate the amplifier in a small sealed chamber of any kind. Improper operations and overheating will result.</p>	



Figure 3.1 – 7234 Back Panel

3 Connections and Startup

This section details the wiring and startup procedures for a single 7234 amplifier operating in Controlled-Voltage mode (factory default). Before connecting the amplifier, make sure the AC power cord is unplugged.



WARNING

ELECTRIC SHOCK HAZARD.
Output potentials can be lethal. Make connections only with AC Power OFF and input signals removed.

3.1 Other Operation Modes and Configurations

The 7234 amplifier can be field-configured for operation in a number of ways. The amplifier can be operated in Controlled-Voltage or Controlled-Current mode. It also can be configured for operation as a part of a multi-amplifier system. These alternate configurations may require special output wiring and/or additional components.

3.1.1 Controlled-Current Operation of a Stand-Alone Amplifier

IMPORTANT: If your application requires Controlled Current operation, the 7234 amplifier first should be wired and tested in Controlled-Voltage mode to verify that the amplifier and input signal are operating correctly. Once proper operation is confirmed, refer to the **Applications** section of this manual for instructions on configuring and operating your amplifier in Controlled-Current mode.

3.1.2 Multi-Amp Operation

If your application requires multi-amp operation for increased voltage or current, each amplifier should

first be wired and tested individually in Controlled-Voltage mode to ensure proper operation.

For **Series operation in Controlled-Voltage mode**, refer to the topic “Multiamp Systems for Increased Current or Voltage” in the **Applications** section of this manual for information on Series system configuration.

For **Series operation in Controlled-Current mode**, you should select one amplifier to be operated as the “Master” amplifier of the system, and then refer to the topic “Controlled Current Operation” in the **Applications** section of this manual for instructions on configuring this amplifier for operation in Controlled-Current mode. After the Master amplifier is configured and tested for Controlled-Current operation, refer to the topic “Multiamp Systems for Increased Current or Voltage” in the **Applications** section of this manual for information on Series system configuration.

For **Parallel operation in Controlled-Voltage mode**, refer to the topic “Multiamp Systems for Increased Current or Voltage” in the **Applications** section of this manual for information on Parallel system configuration.

CAUTION: DO NOT operate paralleled amplifiers in Controlled-Current mode without first contacting AE Techron Technical Support for assistance.

3.2 Connecting the Load

3.2.1 Preparation and Cautions

Before connecting the amplifier, make sure the AC power is disconnected.

Always use the appropriate wire size and insulation for the maximum current and voltage expected at the output. Never connect the output of the amplifier to any other model amplifier, power supply, signal source, or other inappropriate load; fire can result.



WARNING

ELECTRIC SHOCK HAZARD.

Output potentials can be lethal. Make connections only with AC Power OFF and input signals removed.

3.2.2 Connecting the Outputs

Connection to the output of the amplifier is to a 4-position terminal strip with #8 screws. Wires terminated with #8 ring terminals, tinned wires up to 10 AWG in size, or bus bars with 0.18 in. (4.6 mm) holes are recommended when connecting to the output terminals. Connect the load across the terminals marked “OUTPUT” (positive) and “SAMPLED COMMON” (negative/ground). The second terminal, “COMMON,” is used for some advanced applications. The fourth terminal, “CHASSIS GROUND” can be connected to an external ground point such as the rack chassis. See **Figure 3.2**.

IMPORTANT: DO NOT connect the load to the “CHASSIS GROUND” terminal.



Figure 3.2 – Connecting the Load

3.3 Connecting the Input Signal

The signal is connected to the amplifier through a “SIM” (Specialized Input Module) card located on the amplifier back panel. This standard SIM BNC

card can easily be removed and replaced with alternate SIM cards designed for special applications, when required.

The SIM BNC card provides both an unbalanced Input BNC jack and a balanced Input “WECO” terminal block connector. (Mating connector for the WECO connector is provided.) Connect your input signal to the unbalanced or balanced input connector as shown in **Figure 3.3**. Use cables that are high quality and shielded to minimize noise and to guard against possible feedback.

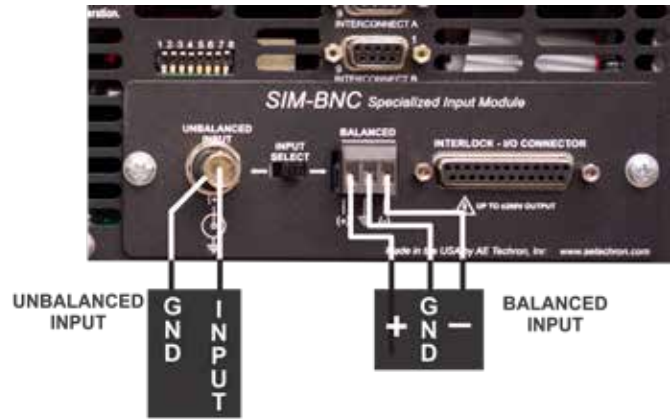

Figure 3.3 – Wiring for Unbalanced or Balanced Input Connector

The Input Select switch, also located on the SIM card, can be used to select balanced or unbalanced input wiring, and also can function as a ground-lift switch for the BNC input connector. The Input Select switch functions by connecting/disconnecting the inverting (–) pin on each input connector to the amplifier ground through a 2.7-ohm resistor (see **Figure 3.4**).

When the Input Select switch is placed in the LEFT position (factory default), the shield on the BNC connector and the inverting (–) pin on the terminal block connector are tied to the amplifier ground, allowing the connectors to be used for Unbalanced input wiring.

When the Input Select switch is placed in the RIGHT position, the inverting pin on the terminal block connector is floating, allowing the connector to be used for balanced input wiring.

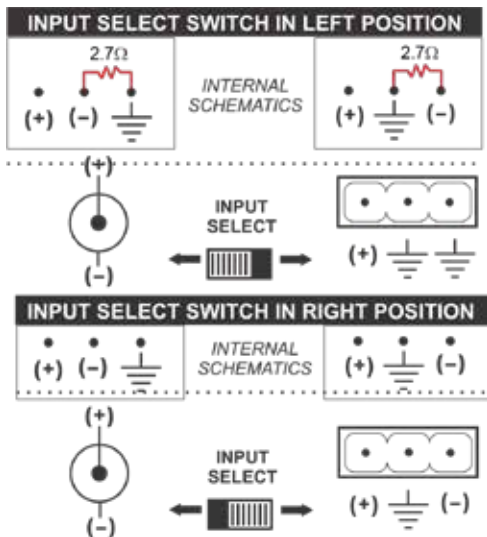

Figure 3.4 – Input Select Switch Settings for Unbalanced or Balanced Input Connectors

IMPORTANT: The Input Select switch can also function as a Ground Lift switch for the BNC Input connector. If circulating currents/ground loops/60-Hz Hum occur when using the BNC Input, move the Input Select switch to the **RIGHT** position to lift the ground on the connector.

3.4 Other Back Panel Controls and Connectors

REMOTE SENSE PORT: The Remote Sense port can be useful when the voltage at the load must be precise. See the **Advanced Configuration** section of this manual for more information on how to use Remote Sense capabilities.

CAUTION

Turn the amplifier OFF before changing DIP switch positions. Some switch changes could result in amplifier damage.

DIP SWITCHES: DIP switches can be used to enable features or configure the amplifier for special applications. See the **Advanced Configuration** section of this manual for more information. Before operating the amplifier, check to make sure all DIP switches are set as intended. The factory default setting for all DIP switches **EXCEPT SW#5** is the **UP** position.

INTERCONNECT PORTS: The Interconnect ports can be used to provide remote control and monitoring of the amplifier, and for connecting multiple amps in push/pull or parallel configurations. See the **Applications** section of this manual for more information.

INTERLOCK I/O CONNECTOR: The Interlock Connector can be used to provide remote control and monitoring of the amplifier, and for connecting multiple amps in series configurations. See the **Applications** section of this manual for information.



Figure 3.5 – Closeup of AC Mains Outlet

3.5 Connecting the AC Supply

The power cord connects to a standard 20A 3-pin IEC-type male connector on the back panel (see **Figure 3.5**). Make sure the Breaker/Switch on the front panel is switched to the OFF (O) position. Make sure the power cord is inserted and seated fully into the IEC connector by moving it slightly back and forth and up and down while pushing in. The power cord is relatively stiff and should be routed so that there is no excessive force pulling to the sides or up or down that would stress the pins or internal connections.

3.6 Start-up Procedure

1. Turn down the level of your signal source.
2. Turn down the gain control of the amplifier.
3. Depress the POWER switch to turn the amplifier ON.
4. Wait for the yellow READY and green RUN LEDs to illuminate.
5. Turn up the Gain control on the amplifier until the desired voltage or power level is achieved.
6. Adjust the input signal level to achieve the desired output level.

WARNING: If amplifier has been unused/inactive for 2 years or more, please startup connected to a low-voltage DC power supply. Start at 10% of the rated voltage and gradually increase to avoid damaging internal components.

4 Amplifier Operation

4.1 Front-Panel Controls

This section provides an overview of Front-Panel controls and indicators found on the 7234.

4.1.1 Power Switch

The Power Switch controls the AC mains power to the amplifier. Switch to the ON position (I) to turn the amplifier on. Switch to the OFF position (O) to turn the amplifier off. See **Figure 4.1**.

The Power Switch also serves as a Breaker. When the Breaker is tripped, the Power Switch moves to a neutral position between ON and OFF. To reset the Breaker, turn the amplifier OFF (O) and then turn it back ON (I).

4.1.2 Gain Control

The Gain Control Knob increases/decreases the gain from 0 – 100% of the overall Gain. Turn the Gain Control fully clockwise for maximum amplifier output. See **Figure 4.2**.

Factory default Gain is 20V/V in voltage mode and 5A/V in current mode. The amplifier can be configured for a maximum Gain of 6V/V in voltage mode by setting the back-panel DIP switch #4 to the DOWN position.

See the **Advanced Configuration** section for information on how to make the amplifier fixed-gain.

4.1.3 Push Buttons

Run and Standby Conditions

The 7234 provides three front-panel soft-touch Push Buttons that control two basic operating conditions: (1) **Run condition** (the high-voltage transformers are energized and the unit will amplify the input signal); and (2) **Standby condition** (the low-voltage transformer is energized but the high-voltage transformers are not and the unit will not amplify the input signal).

By default, the amplifier will automatically enter the Run condition on power-up. To change the factory-default setting and configure the amplifier



Figure 4.1 – Power Switch



Figure 4.2 – Gain Control

to power-up in Standby/Stop mode, please see the **Advanced Configuration** section.

The amplifier will enter one of three Standby modes under the following conditions:

Standby/Stop mode (Standby and Stop LEDs lit): The amplifier has been placed in Standby due to a Stop order or a Stop condition: The Stop button on the amplifier front panel has been pushed or the amplifier has been configured to enter Stop mode on power-up. See the **“Advanced Configuration”** section for information about configuring the amplifier for power-up in **Standby/Stop** mode.

Remote Standby mode (Ready and Standby LEDs lit): The amplifier is functioning properly and all Fault Status modes are clear, but the unit has been placed in Standby by an external condition.

If the amplifier has been configured as a **Follower** amplifier (DIP switch #6 DOWN), it will enter Remote Standby mode when the Enable button is pressed. It will remain in that mode until it receives the Enable signal from an interlocked Master amplifier.

If an amplifier is disabled using a Remote Standby switch, the amplifier will be placed in Remote Standby mode. To return the amplifier to a Run condition, release the Standby condition using the remote switch. See the **Applications** section of this manual for more information on remote amplifier operation.

Standby/Fault mode (Standby and one or more Fault LEDs lit): The amplifier has been placed in Standby due to an Output, Overload, Over Temp or Over Voltage condition. See the topic **“Fault Status Indicators”** later in this section to determine the fault condition being indicated and the action required to clear the fault condition.

Enable, Stop and Reset Buttons

The following details the results when each of the three Push Buttons are pressed on the amplifier front panel. See **Figure 4.3** for Push Button locations.

Enable – When the amplifier is in Standby/Stop mode, pressing the Enable button will release the amplifier from Standby and place the amplifier in Run mode.

Stop – Pressing the Stop button will place the amplifier in Standby/Stop mode (both Standby and Stop LEDs will be lit).

Reset – When the amplifier has been placed in Standby/Fault mode due to a fault condition, pressing the Reset button will return the amplifier to Run mode if the condition causing the fault con-

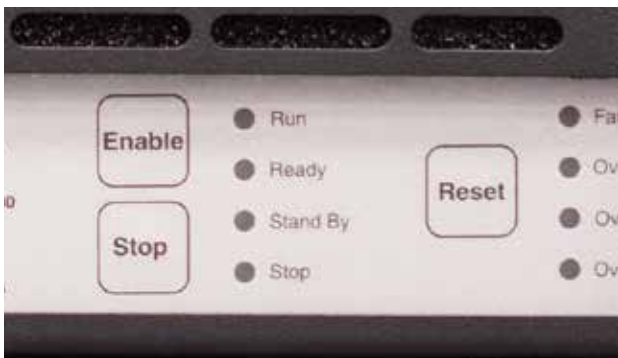

Figure 4.3 – Push Buttons

dition has been cleared and the amplifier has been configured for startup in Run mode. If the amplifier has been configured for startup in Standby/Stop mode, pressing the Reset button will place the amplifier in Standby/Stop mode. Press the Enable button to return the amplifier to Run mode.

4.2 Front-Panel Indicators

4.2.1 Main Status Indicators

Four Main Status indicators are located on the amplifier’s front-panel (see **Figure 4.4**). These LEDs monitor the internal conditions of the amplifier and indicate the current state of operation. The chart in **Figure 4.5** details the operational modes indicated by the Main Status indicators.

NOTE: See the **“Applications”** section for main status indicator interpretation when operating a multi-amp system.

4.2.2 Fault Status Indicators

Four Fault Status indicators are located on the amplifier front panel (see **Figure 4.4**). These LEDs monitor the internal conditions of the amplifier and will illuminate when a fault condition occurs. Depending on the fault condition and the configuration of the unit, the amplifier may be placed in Standby/Fault mode when a fault condition occurs. Refer to the chart in **Figure 4.6** to determine the fault condition being indicated and the action required to clear the fault condition.

NOTE: See the **“Applications”** section for fault status indicator interpretation when operating a multi-amp system.

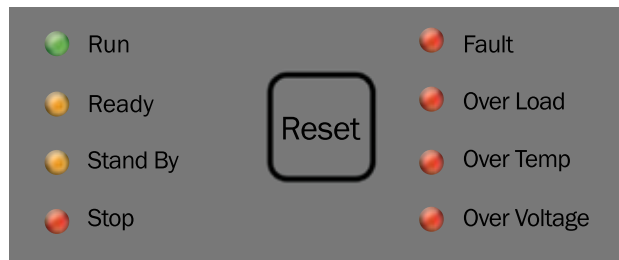

Figure 4.4 – Main Status and Fault Status Indicators

Figure 4.5 – Main Status Indicators

● ● ● Indicator is lit ● Indicator is not lit ○ Indicator may be lit

Main Status Indicators	State of Operation	Action Needed to Return to Run Mode
<ul style="list-style-type: none"> ● Run ● Ready ● Standby ● Stop 	<p>Run mode: The amplifier's high-voltage transformers are energized and the unit will amplify the input signal. Run mode is initiated by: (1) the Enable push button, or (2) when the amplifier powers up in Run mode (factory default). See the Advanced Configuration section for more information.</p>	<p>N/A</p>
<ul style="list-style-type: none"> ● Run ● Ready ● Standby ● Stop 	<p>Remote Standby mode: Remote Standby mode indicates that the amplifier is functioning properly and all Fault Status modes are clear, but it is being held in Standby by an external condition. As configured from the factory (Run mode on startup), the amplifier will enter Remote Standby mode briefly after powering up, and then will move automatically into Run mode. In Remote Standby mode, the amplifier's low-voltage transformer is energized but the high-voltage transformers are not.</p>	<p>If the amplifier remains in Remote Standby mode, it is: 1) Being held in Standby by remote control; or 2) Has been configured as a Follower amplifier. If the amplifier has been configured as a Follower (DIP switch #6 DOWN), it will automatically enter Run mode when the interlocked Master amplifier enters Run mode. Or, if the amplifier is not part of a multi-amp system, place DIP switch #6 in the UP position and then press the Enable button to return to Run mode. If the amp has a remote Standby switch, activate the switch to clear the Remote Standby condition and return the amplifier to Run mode. See the Applications section of this manual for more information on remote amplifier operation.</p>
<ul style="list-style-type: none"> ● Run ● Ready ● Standby ● Stop 	<p>Standby/Stop mode: The amplifier will enter Standby/Stop mode: 1) When the Stop button on the amplifier front panel is pressed; or 2) After powering up if the amplifier is configured to enter Stop mode on startup. In Standby/Stop mode, the amplifier's low-voltage transformer is energized but the high-voltage transformers are not.</p>	<p>To release the amplifier from Standby/Stop mode, press the Enable button.</p>

Figure 4.6 – Fault Status Indicators

● ● ● Indicator is lit ● Indicator is not lit ○ Indicator may be lit

Main Status Indicators	Fault Status Indicators	State of Operation	Action Needed to Clear Fault Condition and Return to Run Mode
<ul style="list-style-type: none"> ● Run ● Ready ● Standby ● Stop 	<ul style="list-style-type: none"> ● Fault ● Over Load ● Over Temp ● Over Voltage 	<p>Output Fault status: This indicates that an Output Fault condition has occurred and the amplifier has been placed in Standby mode. The Fault indicator will light under two conditions: 1) High-frequency oscillation is causing high shoot-through current; or 2) An output transistor has shorted, causing the output fault condition.</p>	<p>This fault condition cannot be cleared using the front-panel Reset button. See the Troubleshooting section for more information on diagnosing and clearing this fault condition.</p>
<ul style="list-style-type: none"> ● Run ● Ready ○ Standby ● Stop 	<ul style="list-style-type: none"> ● Fault ● Over Load ● Over Temp ● Over Voltage 	<p>Over Load status: This indicates that the output of the amplifier could not follow the input signal due to voltage or current limits. Under normal operation with the factory-default settings, an Over Load condition will not place the amplifier in Standby mode. If the amplifier has been configured to be forced to Standby on Over Load, the amplifier will be placed in Standby mode when the Over Load indicator lights.</p>	<p>To remedy the Over Load fault during operation, turn down the level of the input signal until the Over Load indicator turns off. To clear an Over Load fault condition when the amplifier is forced to Standby, turn down the level of the input signal, then push the Reset button.</p>
<ul style="list-style-type: none"> ● Run ● Ready ● Standby ● Stop 	<ul style="list-style-type: none"> ● Fault ● Over Load ○ Over Temp ● Over Voltage 	<p>Over Temp status: The amplifier monitors the temperature inside the high-voltage transformers, low-voltage transformer and in the output stage heat sinks. The Over Temp indicator will light and the amplifier will be placed in Standby mode when the temperature sensors detect a condition that would damage the amplifier. If the Over Temp pulse is extremely short, as in the case of defective wiring or switches, the Over Temp LED may be lit too briefly to observe.</p>	<p>To reset after an Over Temp fault has occurred, make sure the fans are running, and then remove the input signal from the amplifier. Allow the fans to run for about 5 to 15 minutes, and then push and hold the Reset button until the Standby LED turns off. Release the Reset button to return the system to Run mode. See the Troubleshooting section for information on correcting the cause of an Over Temp fault condition.</p>
<ul style="list-style-type: none"> ● Run ● Ready ● Standby ● Stop 	<ul style="list-style-type: none"> ● Fault ● Over Load ● Over Temp ● Over Voltage 	<p>Over Voltage status: This indicates that the AC mains voltage is more than +10% of nominal. The amplifier will be forced to Standby when an Over Voltage condition occurs. When the Over Voltage condition is cleared, the amplifier will automatically return to Run mode.</p>	<p>To clear an Over Voltage fault condition, the AC mains must be brought down to the nominal value. Once the Over Voltage condition has been cleared, press the Reset button to return the amplifier to Run mode. If the amplifier does not return to Run mode, the amplifier may require servicing. Please see the Troubleshooting section for more information.</p>

4.3 Back-Panel Controls and Connectors

This section provides an overview of Back-Panel controls and connectors found on the 7234. Please refer to **Figure 4.7** for visual locations.

AC Supply – Standard 20 amp 3-pin IEC-type male connector.

Output Terminal Strip – Connect output lines from the load to this 4-position terminal strip with #8 screws. It accepts up to 10 AWG wire.

Unbalanced BNC Input Connector – This input option provides a standard unbalanced input.

Balanced Terminal Block (“WECO”) Input Connector – This input option provides a balanced input. A 3-pin mating connector is provided.

Input Selector Switch – This switch can be used to select balanced or unbalanced input wiring, and also can function as a ground-lift switch for the BNC input connector.

Remote Sense Port: The Remote Sense port is a 2-pin terminal block connector used to provide

remote voltage sense at the load. It can be useful when the voltage at the load must be precise.

CAUTION

Turn the amplifier OFF before changing DIP switch positions. Some switch changes could result in amplifier damage.

DIP Switches: The eight DIP switches can be used to enable features or configure the amplifier for special applications. Before operating the amplifier, check to make sure all DIP switches are set as intended. The factory default setting for all DIP switches **EXCEPT SW#5** is the **UP** position.

Interconnect Ports: The two D-sub 9-pin Interconnect ports can be used for voltage, current and temperature monitoring, and for connecting multiple amps in series or parallel configurations.

Interlock I/O Connector: The D-sub 32-pin Interlock Connector can be used to provide remote control and monitoring of the amplifier.

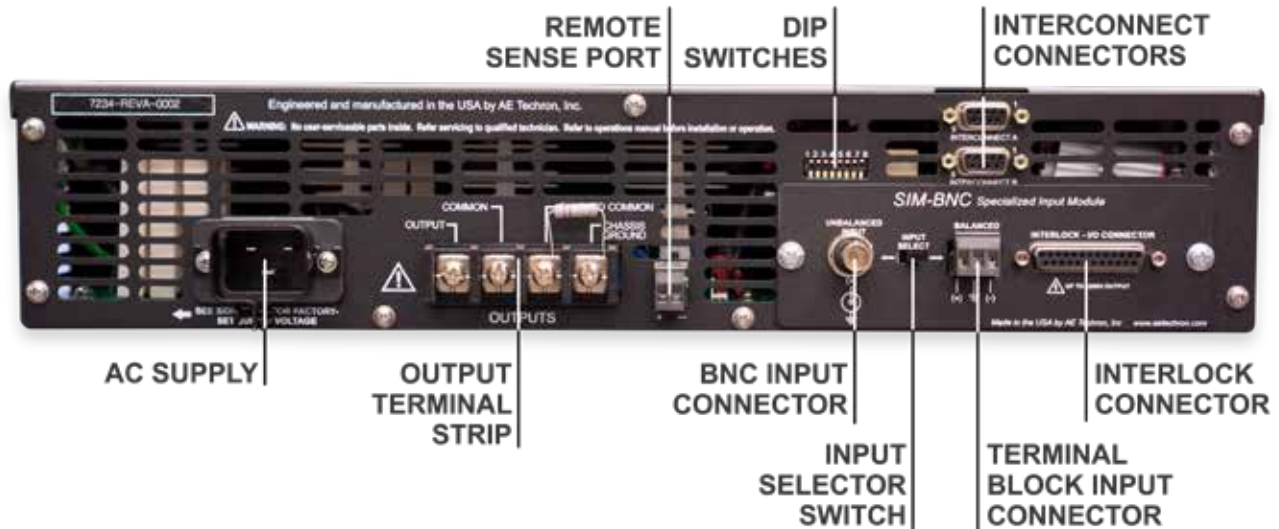

Figure 4.7 – Back Panel Controls and Connectors

5 Advanced Configuration

The 7234 amplifier was designed to offer exceptional versatility in operation. You can choose from a range of field-configurable options, including:

- Operate as a stand-alone amplifier or as part of a multiple-amplifier system.
- Select DC-coupled or AC-coupled operation.
- Select Controlled-Current or Controlled-Voltage modes of operation.
- Enable a 50-kHz low-pass filter.
- Configure the bi-level power supply for use in high voltage applications, high current applica-

tions, or for applications requiring mid-level amounts of both voltage and current.

- Change the maximum amplifier gain from 20:1 to 6:1.
- Operate with variable gain control or at a fixed gain setting (20 or 6).
- Configure the amplifier to enter Standby on startup
- Configure the amplifier to enter Standby when an overload condition occurs.

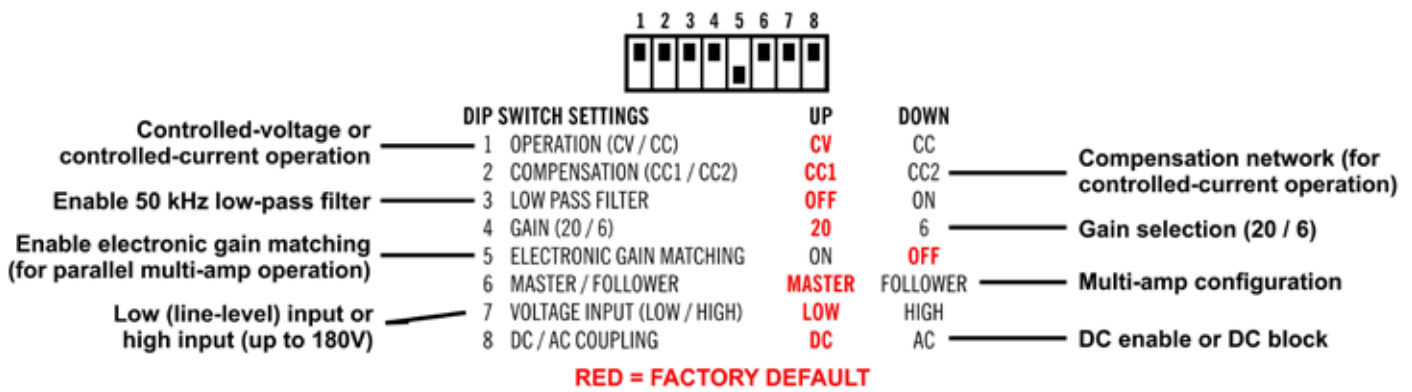

Figure 5.1 – DIP Switch Settings and Descriptions

5.1 DIP Switch Configurations

The 7234 amplifier provides eight DIP switches located on the amplifier back panel above the SIM BNC card. Most configuration settings can be made using these DIP switches. See **Figure 5.1** for DIP switch settings and descriptions.

CAUTION

Turn the amplifier OFF before changing DIP switch positions. Some switch changes could result in amplifier damage.

SW#1: Operation (CV/CC)

When the Operation DIP switch is in the UP position (default), the amplifier will operate in Controlled-Voltage mode, and the amplifier's output voltage will be controlled by its input voltage signal. When this switch is in the DOWN position, the amplifier will operate in Controlled-Current mode,

CAUTION

In Controlled-Current Mode, the load is part of the amplifier circuit, and the relationship of the load to the amplifier is critical. For proper and safe operation in Controlled-Current mode, you must observe the following guidelines:

1. **Properly attach a load before operating the amplifier.**
2. **DO NOT use a blocking capacitor.** The load must have a DC path.
3. **Never leave the load open.** If you feel the load must be fused, which could lead to a potential open circuit, please contact AE Techron Technical Support.
4. **Make sure the load has some inductive component.**
5. **Provide appropriate compensation for the load.**
6. **If oscillation occurs, turn off the amplifier immediately.**

Failure to follow these guidelines may result in damage to the amplifier or load.

and the amplifier's output current will be controlled by its input voltage signal.

IMPORTANT: Controlled-Current operation requires the use of a compensation network, and the 7234's default compensation network may not be suitable for your application. For more information

on Controlled-Current operation, including how to determine and configure a custom compensation network, see the **Applications** section.

SW#2: Compensation (CC1/CC2)

When a 7234 amplifier is used in Controlled-Current mode, the current control loop is tuned with an RC network. Place the Compensation DIP switch in the **Up** position (default) to enable the factory-installed RC network (**CC1**). This network consists of a 68.1 kΩ resistor in series with a 47 nF capacitor. Place the DIP switch in the **Down** position to select **CC2** network. This network is unpopulated, but can be populated with a custom compensation network to fit your requirements. For more information on Controlled-Current operation and installing a custom compensation network, see the “**Applications**” section of this manual.

SW#3: Low-Pass Filter

The Low Pass Filter function inserts a 50 kHz (3-dB down) low-pass filter at the amplifier input to ensure that signals above 50 kHz are not amplified.

Place the Low-Pass Filter DIP switch in the **Up** position (default) to disable the low-pass filter. To enable the low-pass filter, place the DIP switch in the **Down** position.

SW#4: Gain (20/6)

When the Gain DIP switch is in the **Up** position (default), the amplifier's maximum gain will be 20:1. Placing the DIP switch in the **Down** position will change the amplifier's maximum gain to 6:1.

SW#5: Electronic Gain Matching

The Electronic Gain Matching function serves to minimize circulating currents when multiple amplifiers are used in a parallel configuration. When enabled, the Electronic Gain Matching function progressively increases impedance from the voltage gain as current increases, up to a maximum 0.10-ohm increase. This allows the amplifiers to operate in parallel without the use of separate ballast resistors in multi-amp applications up to 20 kHz. For more information on multi-amplifier system configuration and operation, see the **Applications** section.

When this switch is in the **Down** position (default), Electronic Gain Matching is disabled. When the Electronic Gain Matching DIP switch is in the **Up** position, the Electronic Gain Matching function is enabled.

SW#6: Master/Follower

When the Master/Follower DIP switch is in the **Up** position (default), the amplifier will function as a stand-alone amplifier or as a Master amplifier in a multi-amp system. When this switch is in the **Down** position, the amplifier will function as a Follower amplifier in a multi-amp system.

For more information on multi-amplifier system configuration and operation, see the **Applications** section.

SW#7: Voltage Input (Low/High)

When the Voltage Input DIP switch is in the **Up** position (default), the voltage input is set to line level and the amplifier can be configured for use in a Parallel or Push/Pull multi-amp system, or as a Master amplifier in a Series multi-amp system. When this switch is in the **Down** position, voltage input is set to high, and the amplifier can be configured for use as a Follower amplifier in a Series multi-amp system.

SW#8: DC/AC Coupling

When the DC/AC Coupling DIP switch is in the **Up** position (default), the amplifier can receive and amplify both DC and AC signal. When this switch is in the **Down** position, a 2-Hz high-pass filter on the inputs prevents the transmission of DC signal.

5.2 Internal Configurations

The 7234 amplifier contains a main circuit board and a power supply board with jumpers, switches, and other controls that can be used to alter the amplifier operation from the factory defaults. Using these controls, you can:

Main Board:

- Install a custom compensation network for use in Controlled-Current operation,
- Configure the amplifier to operate with a fixed gain instead of the default variable gain,

- Configure the amplifier to enter Standby on startup instead of entering Run mode (default)
- Configure the amplifier to enter Standby when an Overload fault condition occurs.

Power Supply Board

- Change the amplifier voltage potential for high-current or high-voltage operation
- Change the bi-level power supply function for auto, locked low, or locked high operation

The main and power supply boards can be accessed by removing the amplifier top cover. To remove the amplifier top cover, complete the steps detailed in the following section.

5.2.1 Amplifier Top Cover Removal

Tool Required

#2 Phillips screwdriver

Procedure

1. Remove power from the amplifier and disconnect any load from the amplifier outputs. Wait a minimum of three minutes to allow the amplifier's capacitors to discharge.
2. Remove the amplifier's front grill cover by firmly pulling the grill cover away from the front panel. The grill is held by magnets.
3. Use the Phillips screwdriver to remove nine (9) screws:
 - a. Three (3) screws from each side
 - b. One (1) screw from the back
 - c. Two (2) screws from the front (after the grill cover is removed).
4. Lift the cover straight up to remove it and set it aside.

! DANGER

Uninsulated terminals with AC mains potential are exposed when the top cover is removed. Do not proceed until the amplifier has been turned off and the AC Mains has been disconnected.

! CAUTION

After turning the amplifier off, let the unit sit for 3-5 minutes before removing the top cover. This will allow the electrical charge in the power supply capacitors to discharge.

! CAUTION

The front grill is held on by strong magnets. When replacing the front grill, hold the grill by its side edges and be sure to keep fingers clear of the grill back. Pinching injuries can occur if the grill is replaced improperly.

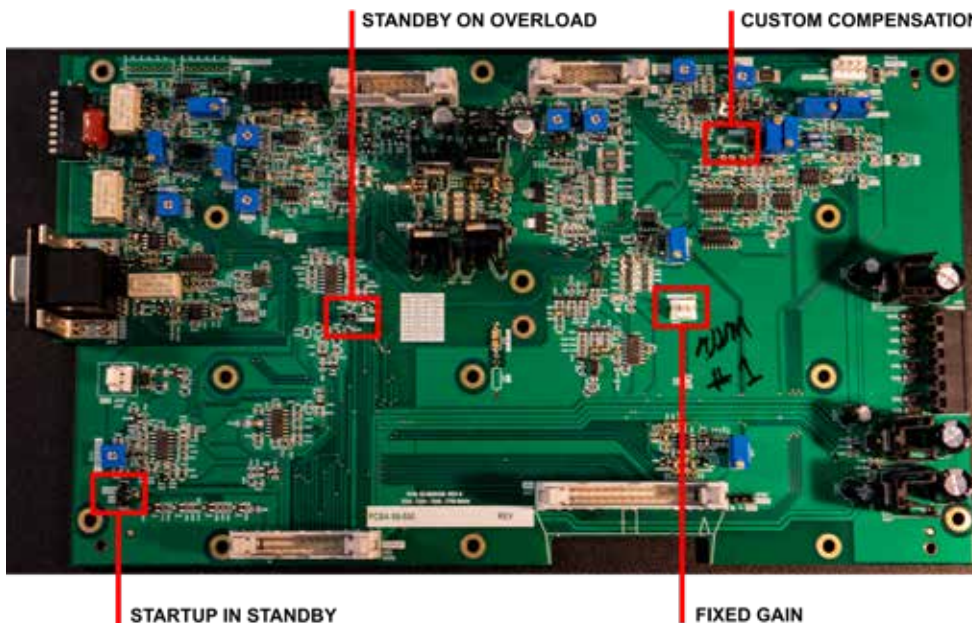

Figure 5.2 – Main Board Configuration Locations

5. To replace the top cover, slide the cover in to place on the amplifier and replace the nine screws.
6. Position the grill near the front panel and snap into place.

5.2.2 Configuration Settings on the Main Board

Refer to Figure 5.2 for main board configuration locations.

Custom Compensation Network

When the 7234 amplifier is used in Controlled-Current mode, the current control loop is tuned with an RC network. The factory default network (CC1) provides 68.1k ohm resistance and 47 nF capacitance. If this default network is not adequate for your application and load, CC2 can be used to install a custom RC network on the amplifier main board.

For information on installing a custom RC network, please see the topic “**Controlled Current Operation**” in the *Applications* section of this manual.

Enable/Stop on Power-up

The 7234 amplifier will power-up to Run Mode when a shunt is placed across pins 1 and 2 on the Enable/Stop jumper (default setting). See **Figure 5.3**. To cause the 7234 amplifier to enter Standby

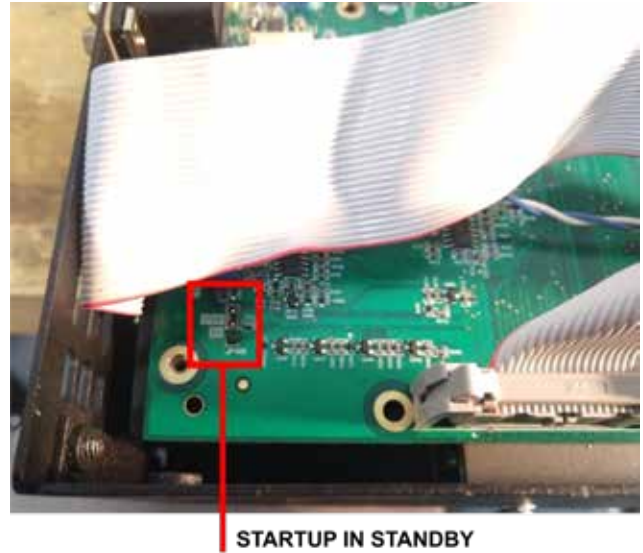

Figure 5.3 – Enable/Stop on Power-up Configuration

(Stop Mode) on power-up, place the shunt across pins 2 and 3.

Fixed or Variable Gain

The 7234 amplifier ships with an enabled Gain Control knob, which is located on the amplifier front panel. To disable the Variable Gain control and set for a Fixed Gain, locate the Gain Control Bypass jumper, remove the gain control wire, and place a shunt across the two pins at that location. See **Figure 5.4**.

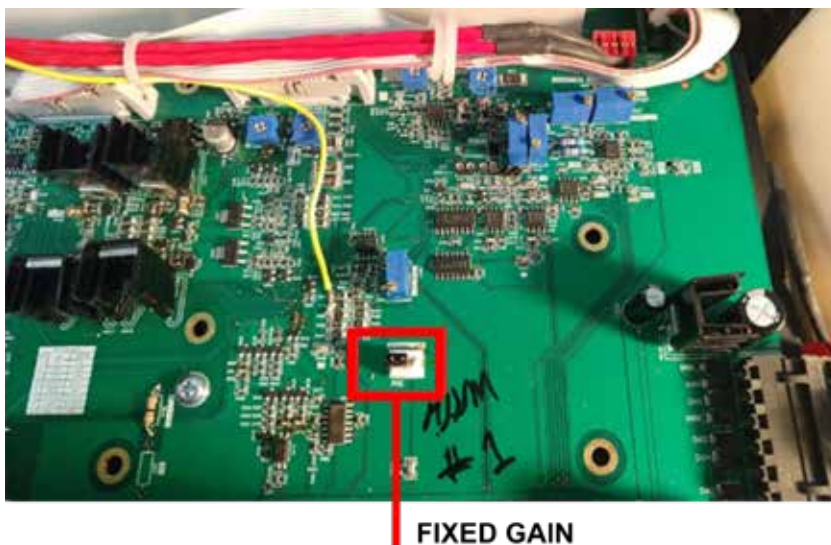

Figure 5.4 – Configure for Fixed or Variable Gain

Standby on Overload

The 7234's IOC (Input/Output Comparator) Distortion Alert circuit continuously compares the waveforms observed at the amplifier input and output. When a distortion between the two waveforms of more than 0.5% occurs, the IOC circuit will activate, and the Overload LED will light, but the

amplifier will continue to operate. To configure the 7234 to move to Standby (Fault mode) when the IOC circuit is activated, locate the Overload Latch (see **Figure 5.5**) and place a shunt across the two pins of the jumper.

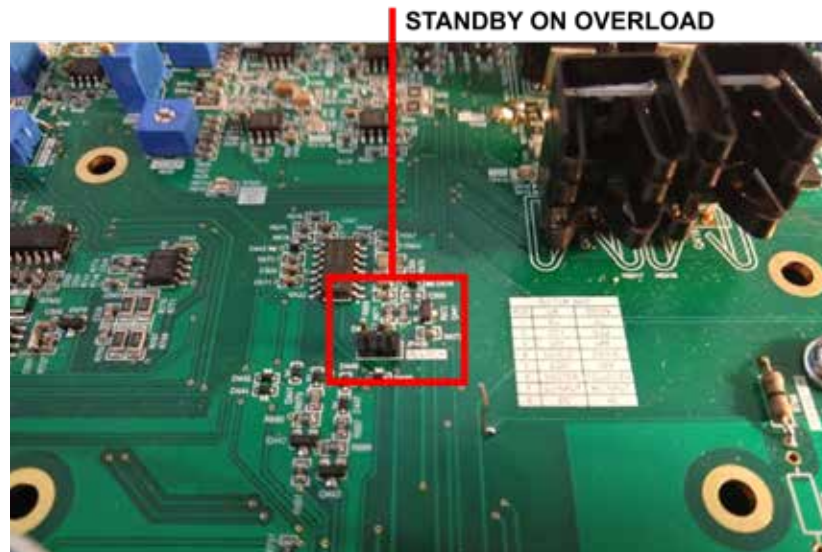

Figure 5.5 – Configure for Standby (Fault Mode) on Overload

5.2.3 Configuration Settings Located on the Power Supply Board

The following custom settings are configured on the Power Supply Board:

- Amplifier Voltage Potential setting (high current or high voltage)
- Bi-Level Power Supply setting

Power Supply Settings for Increased Voltage or Current

The 7234 amplifier features a bi-level power supply that contains two, dual-secondary transformers. The secondary rails of each transformer and the two transformers themselves can be placed in a series or parallel configuration, as shown in **Figure 5.6**, providing a range of options for operating with increased voltage or current capabilities.

As shipped from the factory, the 7234 is set to operate with the transformer rails configured in series

and the dual transformers configured in parallel, providing a voltage potential of 90V.

During normal operation, the 7234 will use the signal received at input to calculate the expected voltage requirements of the application. When voltages higher than 90V are required, the transformers will automatically be switched to a series configuration to provide up to 180V output.

When the 7234 senses that the voltage required has dropped below the 90V limit, the transformers will automatically be returned to a parallel configuration, reducing heat output and increasing operating efficiency.

While this default configuration works well for most applications, some applications, especially those with a voltage requirement near the 90V switching

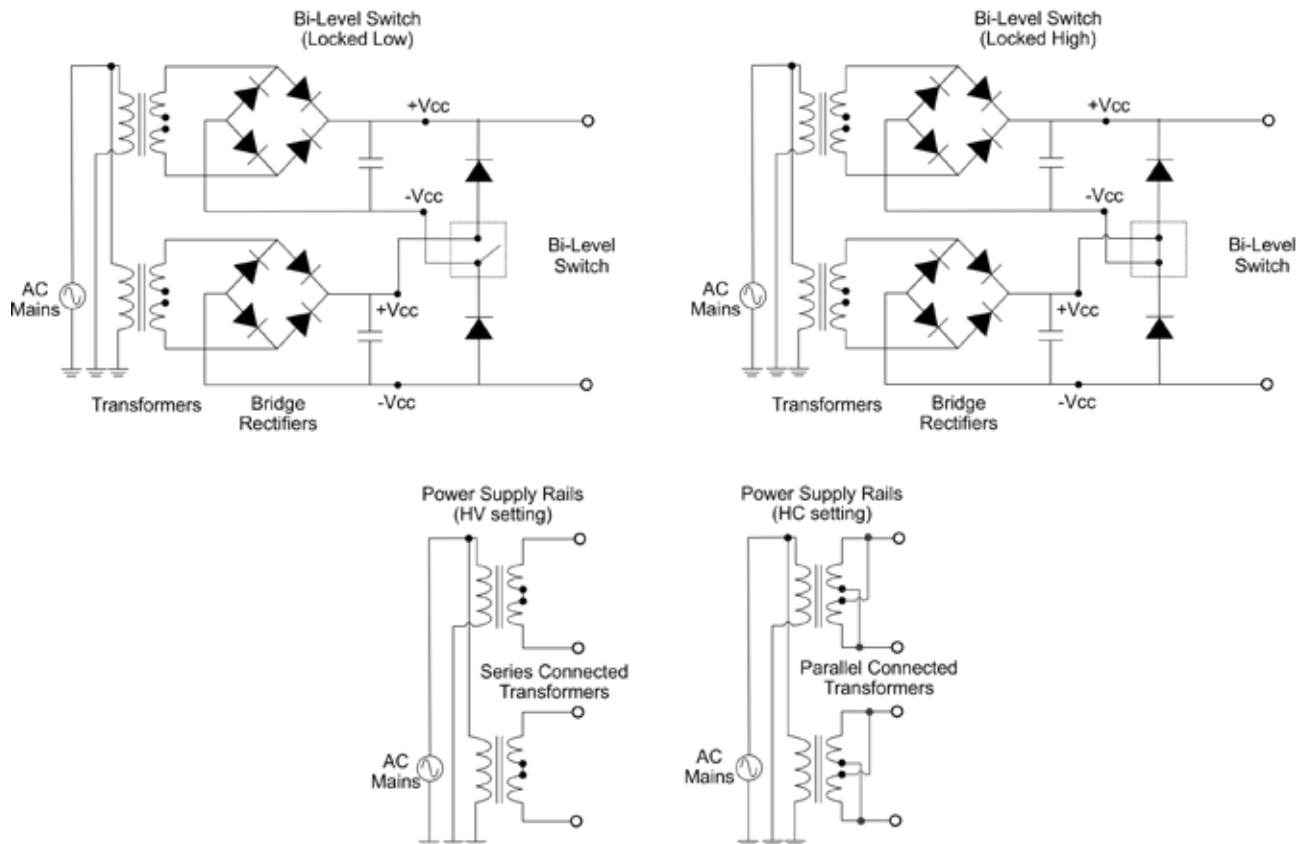

Figure 5.6 – Power Supply Settings

frequency, may require a fixed configuration for maximum continuous operation. For those applications, the Bi-level switch allows the user to select the High setting for a fixed series configuration with higher voltage potential, or the Low setting for a fixed parallel configuration with a lower voltage potential.

In the same way, the two secondaries in each transformer can be configured for series (high voltage: 180V) or parallel operation (high current: 90V)

operation via user-selectable plugs on the Power Supply Board.

Refer to the chart in **Figure 5.7** for recommended applications and expected output voltage based on the various configuration settings.

Accessing the Power Supply Board

To access the Power Supply Board, follow the instructions given previously in this section under the topic “**Amplifier Top Cover Removal.**” The

OUTPUT VOLTAGE	LOAD (ohms)		BI-LEVEL SWITCH	POWER SUPPLY RAILS	RECOMMENDED APPLICATIONS
	Continuous	Pulse			
45	0.5 - 1	0.25 - 0.75	Low	HC	High current operation
45-90	2 - 4	1 - 2	Auto	HC	Mid-level operation
90			High	HC	Not recommended
90	2 - 4	1 - 2	Low	HV	Fastest rise to >45V; <90V
90-180	8 - 16	4 - 16	Auto	HV	High voltage operation
180	8 - 16	4 - 16	High	HV	Fastest rise to >90V; <180V

Figure 5.7 – Recommended Power Supply Configuration Settings by Application

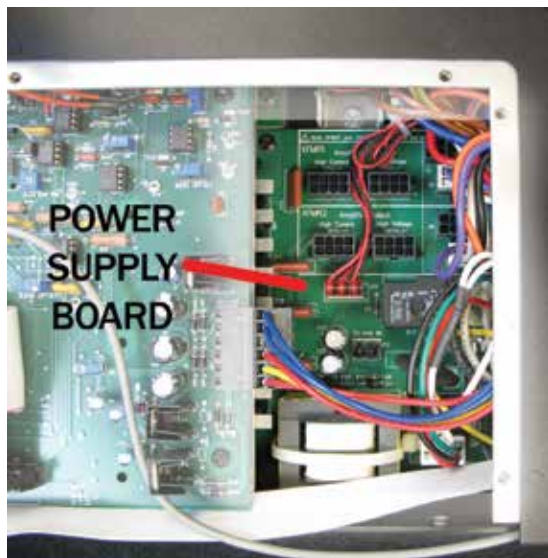

Figure 5.8 – Accessing the Power Supply Board

Power Supply Board is located to the right of the Main Board, as shown in **Figure 5.8**.

Changing Amplifier Voltage Potential

The amplifier can be configured for High Current (90V) or High Voltage (180V) operation via user-selectable plugs on the Power Supply Board. Complete the following steps to change the amplifier voltage potential.

1. Locate the two XFMR sections (left of Line Voltage sections) (see **Figure 5.9**).
2. For High Current (90V) Output (see **Figure 5.10**).
3. For High Voltage (180V) Output (see **Figure 5.11**).

Changing Bi-Level Power Supply Setting

The amplifier provides three Bi-Level switch settings: Automatic, High, or Low. The user can select between settings via a switch on the Power Supply Board.

To access and change the Bi-Level Power Switch, follow these steps:

1. Locate the SIM Input Card on the right side of the rear panel of the amplifier.
2. Using a #2 Phillips screwdriver, remove the two screws located at the edges of the SIM card.
3. Keeping the ribbon cable attached, remove the

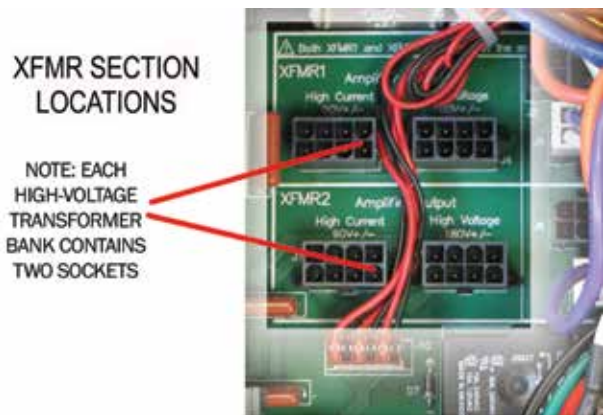

Figure 5.9 – Location of Amplifier High-Voltage Transformer Sockets

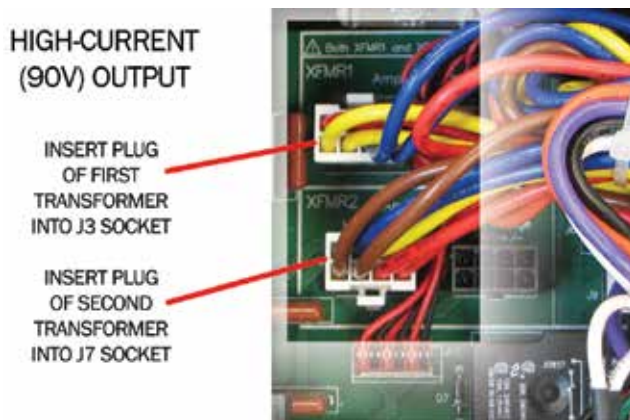

Figure 5.10 – J3 and J7 Plug Locations for High-Current Output

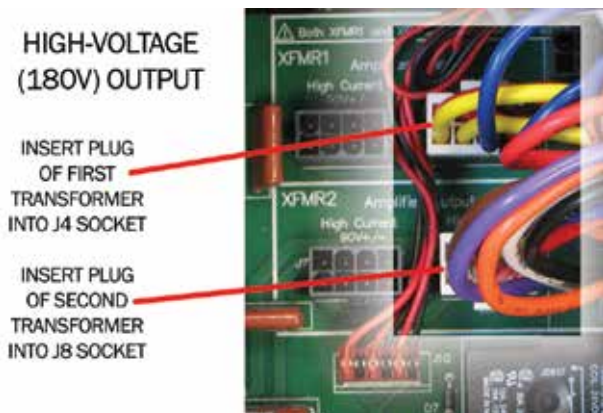

Figure 5.11 – J4 and J8 Plug Locations for High-Voltage Output

SIM card from the amplifier until it is completely clear from the card bay.

4. Locate Bi-Level Power Switch, S1, a black, three-position switch at the rear of the card bay. (See **Figure 5.12**)
5. Move Black switch to desired setting. If necessary, use a pointed, non-metallic object (such as a pen) to help in moving the switch.
 - a. Automatic – Left
 - b. Low – Middle
 - c. High – Right



Figure 5.12 – Bi-Level Power Switch Location

6 Applications

The procedures outlined in this section assume competence on the part of the reader in terms of amplifier systems, electronic components, and good electronic safety and working practices.

6.1 Remote Status and Control using the Interconnect Ports



CAUTION

These Application instructions for the Interconnect Ports apply only to units with a **serial number ending in "B."** Units with a **serial number ending in "A"** were built using a different configuration for these 9-pin D-Sub connectors. For proper wiring for units with a serial number ending in "A," please refer to Appendix A of this manual.

AE Techron 7234 amplifiers come with two back-panel female 9-pin D-Sub connectors that can be used to provide remote control and monitoring of the amplifier.

The information provided here will instruct you in the wiring of several control and status applications including:

- Remote Enable/Standby
- Temperature monitor
- Current monitor
- Voltage monitor

Figure 6.1 maps the pins used for these applications. NOTE: Both 9-pin D-Sub connectors have the same pin-outs and either port can be used for remote applications.

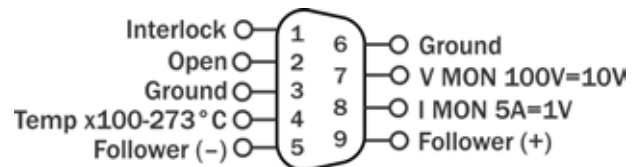

Figure 6.1 – Remote Status and Control Pin-outs on 9-pin D-Sub Connectors

6.1.1 Remote Enable/Standby

Using one of the 9-pin D-Sub connectors located on the back panel of the amplifier, you can remotely Enable the amplifier and/or place the unit in Standby mode. See **Figure 6.2**.

Remote Enable/Standby

Purpose: Use a switch or optocoupler to remotely disable the amplifier and place it in Standby mode. Also, return the amplifier from Standby mode to the Run condition.

Method: Short PIN 1 (Interlock) of connector to Ground (PIN 3 or PIN 6) using a dry contact switch or optocoupler. In multi-amp applications, a switch can be used for Parallel systems, but an optocoupler must be used for Series systems. Multiple amplifiers (sharing the same Ground power connections) can be simultaneously forced to Standby by daisy-chaining Interlock (PIN 1) across amps. When Interlock (PIN 1) is shorted to Ground (PIN 3 or PIN 6), amplifier is placed in Standby mode. When switch is open, amplifier is released to the Run condition.

Signal Type: DC

Level when Asserted: 0 to 8 V

Level when Deasserted: 10 to 15 V

IMPORTANT: The amplifier must be configured for Ready mode at startup (factory default) or the Run button must be pressed at the amplifier front panel at startup. The Remote Enable/Standby circuit will not function if the Startup to Standby Latch has been activated on the amplifier.

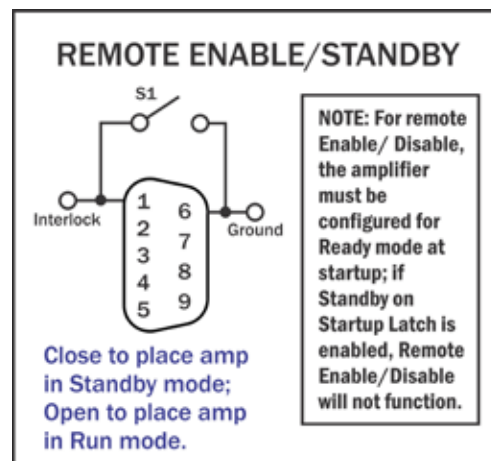

Figure 6.2 – Remote Enable/Standby

6.1.2 Remote Monitoring of Temperature

Using one of the 9-pin D-Sub connectors located on the back panel of the amplifier, you can remotely monitor the temperature at the heat-sinks of the amplifier.

Remote Monitoring of Temperature

Purpose: Use a voltage meter to monitor temperature at the heat-sinks.

Method: Connect a voltage meter to monitor the temperature at the heatsinks of the amplifier. Connect across Temp (PIN 4) and Ground (PIN 3 or 6). See **Figure 6.3**.

Signal Type: AC

Level: (VDC X 100) - 273 = degrees Celsius

IMPORTANT: This circuit has a 1K build-out resistor. Make sure the monitor function has sufficient impedance to avoid accidentally influencing status.

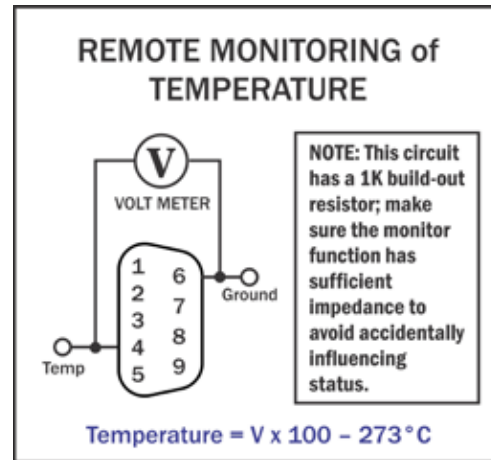

Figure 6.3 – Remote Temperature Monitor

Most digital multimeters have an input impedance of 1 megohm and would work well for this application.

6.1.3 Remote Monitoring of Current

Using one of the 9-pin D-Sub connectors located on the back panel of the amplifier, you can remotely monitor current output.

Remote Monitoring of Current Output

Purpose: Use a voltage meter to monitor output current.

Method: Connect a voltage meter to monitor the output current being produced by the amplifier. Connect across I MON (PIN 8) and Ground (PIN 3 or 6). See **Figure 6.4**.

Signal Type: AC

Level: 5A/V

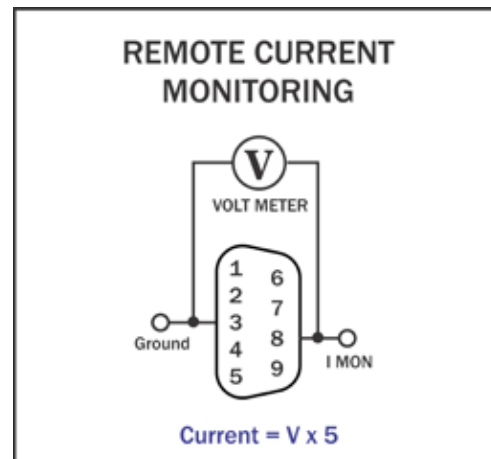

Figure 6.4 – Remote Current Monitor

6.1.4 Remote Monitoring of Voltage

Using one of the 9-pin D-Sub connectors located on the back panel of the amplifier, you can remotely monitor voltage output.

Remote Monitoring of Voltage Output

Purpose: Use a voltage meter to monitor output voltage.

Method: Connect a voltage meter to monitor the output voltage being produced by the amplifier. Connect across V MON (PIN 7) and Ground (PIN 3 or 6). See **Figure 6.5**.

Signal Type: AC

Level: 10V/V

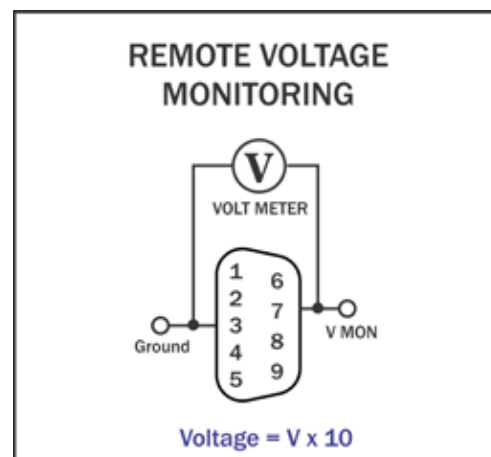

Figure 6.5 – Remote Voltage Monitor

6.2 Remote Status and Control using the SIM Interlock I/O Connector

AE Techron 7234 amplifiers come with a SIM-BNC input module that also contains a female, 25-pin D-Sub connector. This connector can be used

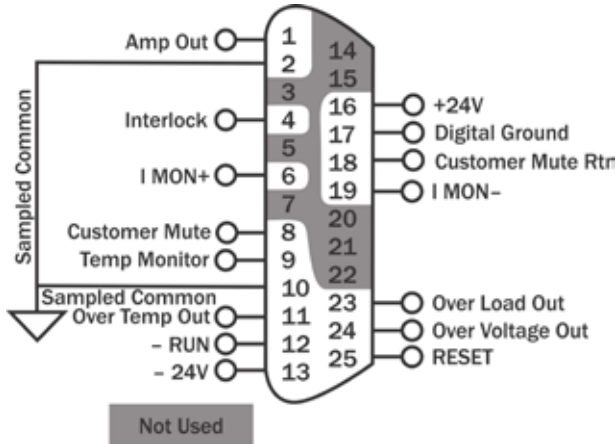

Figure 6.1 – Remote Status and Control Pinouts on 25-pin D-Sub Connector (SIM card)

to provide remote control and monitoring of the amplifier.

The information provided here will instruct you in the wiring of several control and status applications including:

- Run/Standby status
- Amplifier status: Run, Over-temperature, Overload, Overvoltage; and Reset after Overload error
- Remote Enable/Standby
- Current monitor
- Temperature monitor
- Activate Blanking circuit

Figure 6.6 maps the pins used for these applications.

6.2.1 Remote Run/Standby Status Monitor

Using the SIM-BNC Interlock connector located on the back panel of the amplifier, you can remotely monitor the Run/Standby status of the amplifier.

Remote Run/Standby Status

Purpose: Use a voltage meter to monitor the status of the amplifier to determine if the amplifier is in a “Run” or “Standby” state.

Method: Connect a voltage meter to monitor the circuit voltage. Connect across PIN 4 (Interlock) and PIN 10 (Sampled Common).

When the voltage meter reads greater than 10V, the amplifier is in the Run state; when the meter reads less than 10V, the amplifier is in the Standby state. See Figure 6.7.

Signal Type: DC

Level when Asserted: >10 V

Level when Deasserted: <10 V

IMPORTANT: This circuit has a 100K pull-up resistor. Make sure the monitor function has sufficient impedance to avoid accidentally influencing status.

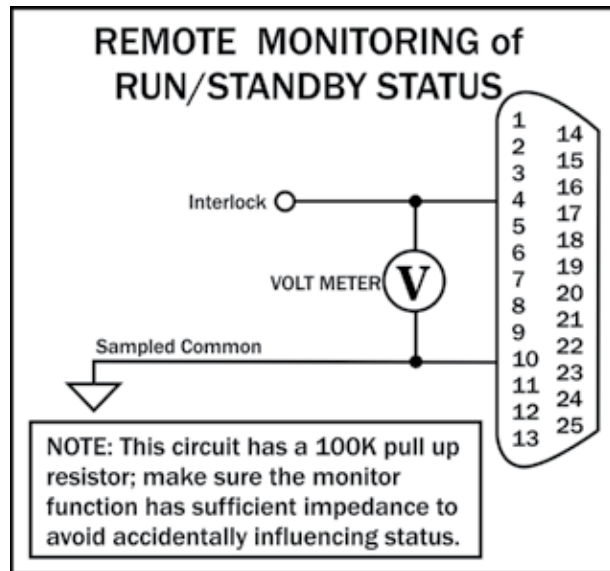

Figure 6.7 – Remote Run/Standby Monitor

6.2.2 Remote Amplifier Status & Reset

The SIM Interlock I/O Connector can be used to create a circuit to monitor remotely one or more amplifier conditions, including Run status, Over-temperature, Overload and Overvoltage. The circuit can also be constructed to allow remote reset

of the amplifier when it is forced to Standby due to Over-load conditions.

Use a male, 25-pin D-Sub connector and high-quality wire to build the circuit. **Figure 6.8** schematic details the circuit and components required for all status and reset functions.

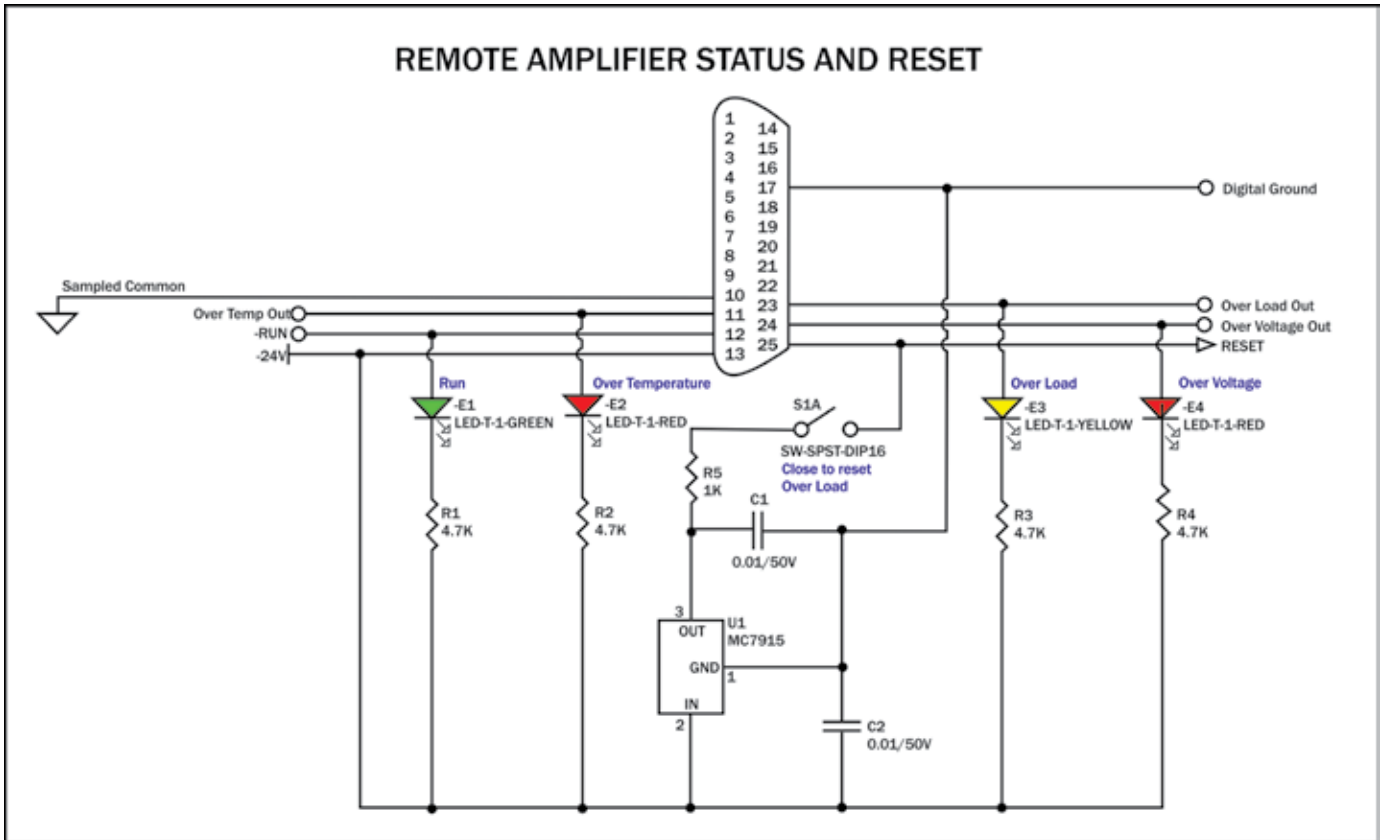

Figure 6.8 – Remote Status and Reset Schematic

Remote Signal of Over Temperature Condition

Purpose: LED, when lit, signals Over Temperature condition.

Method: Use a 6mA series resistor of 4.02 Kohm for LED or OPTO, tie OverTemp Out (PIN 11) to -24V source (PIN 13).

Signal Type: DC

Level when Asserted: -24V

Level when Deasserted: 0V

Note: When amp is normal, this pin is pulled to -24V through a 47.5K-ohm resistor; when amp is in OverTemp state, transistor Q37 turns on and sources chassis ground as an output. Do not exceed 20 milliamps.

An OverTemp condition will force the amp to Standby. The amplifier will automatically move to Run when temperature cools to operating levels.

Remote Signal of Run Condition

Purpose: LED, when lit, signals Run state.

Method: Use a 6mA series resistor of 4.02K-ohm for LED or OPTO, tie Run (PIN 12) to –24V source (PIN 13).

Signal Type: DC

Level when Asserted: –24V

Level when Deasserted: 0V

Remote Signal of OverLoad Condition

Purpose: LED, when lit, signals Overload condition.

Method: Use a 6mA series resistor of 4.02K-ohm for LED or OPTO, tie OverLoad Out (PIN 23) to –24V source (PIN 13).

Signal Type: DC

Level when Asserted: –24V

Level when Deasserted: 0V

Note: When amp is normal, this pin is pulled to –24V through a 47.5K-ohm resistor; when amp is in Overload state, transistor Q36 turns on and sources chassis ground as an output. Do not exceed 20 milliamps.

An Over Load condition will not place the amplifier in Standby when operating with the factory default settings. In order to clear the fault condition, reduce the input levels until the Over Load LED turns off. However, if the Standby Mode on Over Load option is set, an Over Load condition will force amp to Standby. To return the amplifier to Run mode, reduce the input signal level, then trigger a Reset command using the front-panel Reset button or a remote amplifier Reset command.

Remote Signal of OverVoltage Condition

Purpose: LED, when lit, signals Overvoltage condition.

Method: Use a 6mA series resistor of 4.02K-ohm for LED or OPTO, tie OverVoltage Out (PIN 24) to –24V source (PIN 13).

Signal Type: DC

Level when Asserted: –24V

Level when Deasserted: 0V

Note: When amp is normal, this pin is pulled to –24V through a 47.5K-ohm resistor; when amp is in Overvoltage state, transistor Q29 turns on and sources chassis ground as an output. Do not exceed 20 milliamps.

Reset from Standby

Purpose: Switch, when thrown, returns amp to Run condition after an Overload condition.

Method: Use a dry-contact switch, voltage regulator (MC7915), and two 0.01/50V capacitors; wire the circuit as shown (above). Assert 15V for at least 100 ms to clear the error condition.

Signal Type: DC

Level when Asserted: –15V

Level when Deasserted: 0V

Note: Tie to PIN 13 (–24V dc) and create a –15V dc source; <2mA required for reset. Connect the –15V dc source to PIN 25 (Reset) through a 1K buffer resistor to reset.

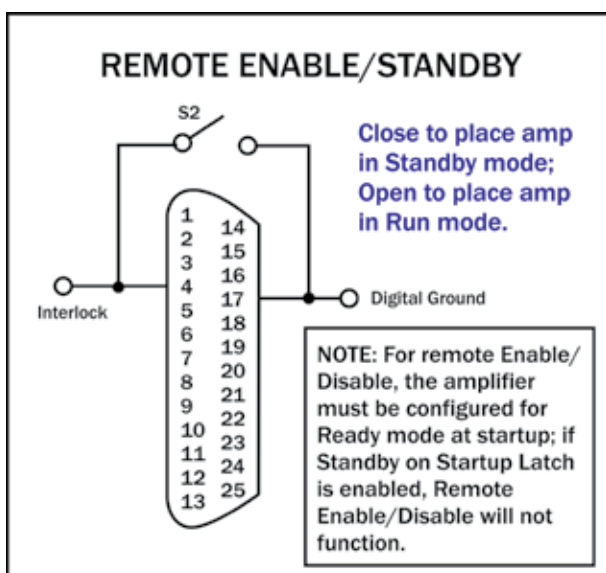

Figure 6.9 – Remote Enable/Standby

6.2.3 Remote Enable/Standby

Using the SIM-BNC Interlock connector located on the back panel of the amplifier, you can remotely Enable the amplifier and/or place the unit in Standby mode. See Figure 6.9.

Remote Enable/Standby

Purpose: Use a switch or optocoupler to remotely disable the amplifier and place it in Standby mode. Also, return the amplifier from Standby mode to the Run condition.

Method: Short PIN 4 of amplifier to Digital Ground (PIN 17) using a dry contact switch or optocoupler. In multi-amp applications, a switch can be used for Parallel systems, but an optocoupler must be used for Series systems. Multiple amplifiers (sharing the same Sampled Common power connections) can be simultaneously forced to Standby by daisy-chaining Interlock (PIN 4) across amps.

When Interlock (PIN 4) is shorted to Digital Ground (PIN 17), amplifier is placed in Standby mode. When switch is open, amplifier is released to the Run condition.

Signal Type: DC

Level when Asserted: 0 to 8 V

Level when Deasserted: 10 to 15 V

IMPORTANT: The amplifier must be configured for Ready mode at startup (factory default) or the Run button must be pressed at the amplifier front panel at startup. The Remote Enable/Standby circuit will not function if the Startup to Standby Latch has been activated on the amplifier.

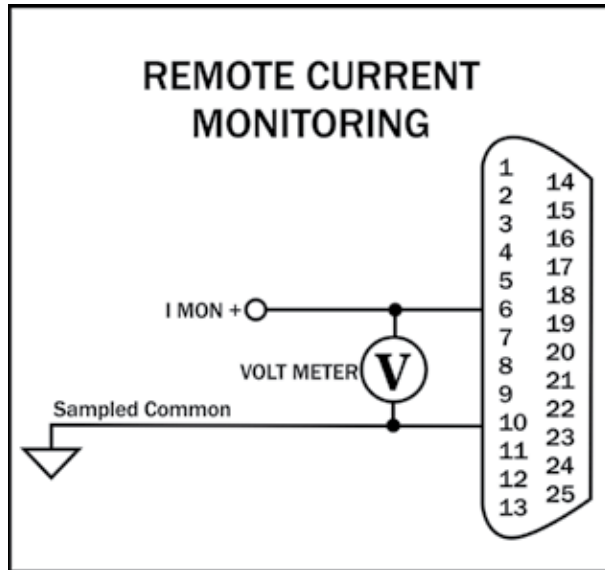

Figure 6.10 – Remote Current Monitoring

6.2.4 Remote Monitoring of Current

Using the SIM-BNC Interlock connector located on the back panel of the amplifier, you can remotely monitor current output.

Remote Monitoring of Current Output

Purpose: Use a voltage meter to monitor output current.

Method: Connect a voltage meter to monitor the output current being produced by the amplifier. Connect across PIN 6 (I MON+) and PIN 10 (Sampled Common). See **Figure 6.10**.

Signal Type: AC

Level: 5A/V

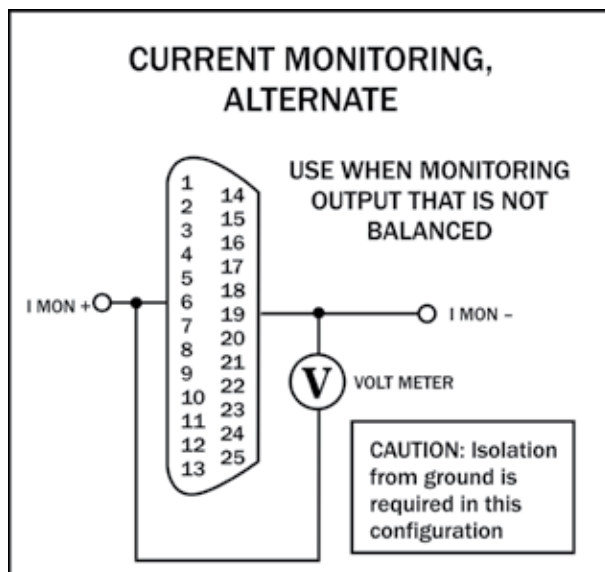

Figure 6.11 – Remote Current Monitoring, Alternate Method

Remote Monitoring of Current Output - Alternate Method

Purpose: Use a voltage meter to monitor output current when output is not balanced.

Method: Connect a voltage meter to monitor the output current being produced by the amplifier. Connect across PIN 6 (IMON+) and PIN 19 (IMON-). See **Figure 6.11**.

Signal Type: AC

Level: 2.5A/V

CAUTION: To avoid ground loops, isolation from ground must be provided. Use of a differential probe is recommended.

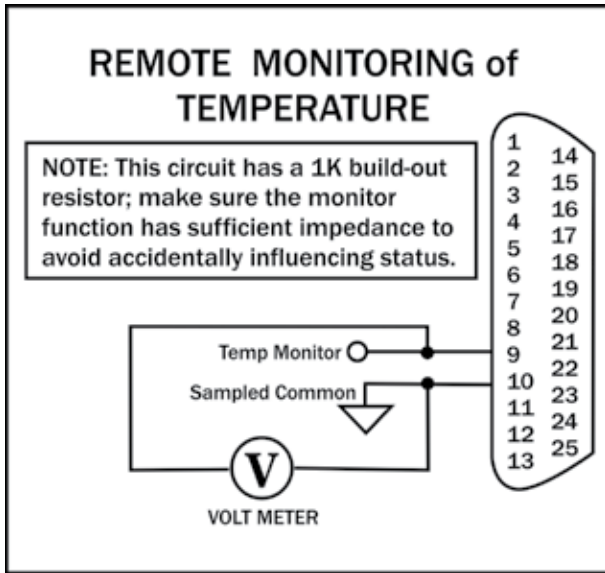

Figure 6.12 – Remote Monitoring of Temperature

6.2.5 Remote Monitoring of Temperature

Using the SIM-BNC Interlock connector located on the back panel of the amplifier, you can remotely monitor the temperature at the heat-sinks of the amplifier.

Remote Monitoring of Temperature

Purpose: Use a voltage meter to monitor temperature at the heat-sinks.

Method: Connect a voltage meter to monitor the temperature at the heatsinks of the amplifier. Connect across PIN 9 (TEMP MONITOR) and PIN 10 (Sampled Common). See **Figure 6.12**.

Signal Type: AC

Level: (VDC * 100) - 273 = degrees Celsius

IMPORTANT: This circuit has a 1K build-out resistor. Make sure the monitor function has sufficient impedance to avoid accidentally influencing status. Most digital multimeters have an input impedance of 1 megohm and would work well for this application.

Blanking Circuit Activation

Purpose: Activate the blanking circuit that shuts down the amplifier output stage in less than 10 μs.

Method: Build a switchable circuit using an external, isolated 5V power supply that can apply a +5V signal to PIN 8. Connect across PIN 8 (Blanking) and PIN 18 (Blanking Return). See **Figure 6.13**.

Signal Type: DC

Level when Asserted: 5-6 Vdc

Level when Deasserted: 0 Vdc

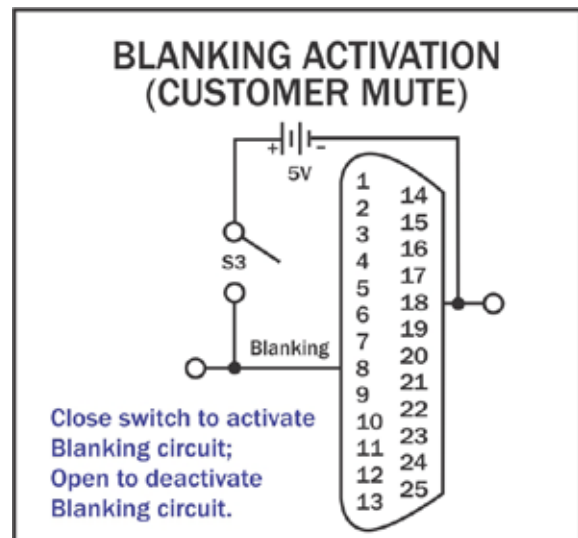

Figure 6.13 – Blanking Activation

6.3 Controlled Current Operation

The procedures outlined in this section assume competence on the part of the reader in terms of amplifier systems, electronic components, and good electronic safety and working practices.

NOTE: Controlled-current operation for multi-amp systems is not recommended. If you find your application requires this configuration, please contact AE Techron Technical Support for more details.

6.3.1 Controlled-Voltage vs. Controlled-Current Modes of Operation

AE Techron 7234 amplifiers can be field-configured to operate as **Voltage Amplifiers** (Voltage-Controlled Voltage Source) or as **Transconductance Amplifiers** (Voltage-Controlled Current Source). The mode selection is made via a DIP switch on the amplifier's back panel. See the **Advanced Configuration** section for more information.

When configured as a **Controlled-Voltage** source (voltage amplifier), the amplifier will provide an output voltage that is constant and proportional to the control (input) voltage. If the load's impedance changes, the amplifier will seek to maintain this ratio of input to output voltage by increasing or decreasing the current it produces, as long as it is within the amplifier's ability to create the required current. Use this mode if you want the output voltage waveform to be like the input waveform (see **Figure 6.13**).

Conversely, when configured as a **Controlled-Current** source (transconductance amplifier), the amplifier will provide an output current that is constant and proportional to the control (input) voltage. If the load's impedance changes, the amplifier will seek to maintain this transconductance (ratio of input voltage to output current) by increasing or decreasing the voltage it produces, as long as it is within the amplifier's ability to create the required voltage. Use this mode if you want the output current waveform to be like the input waveform (see **Figure 6.14**).

CONTROLLED-VOLTAGE MODE

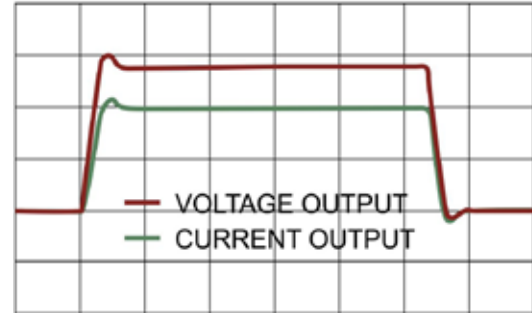

Figure 6.13 – Input to Output Comparison, Controlled-Voltage Operation

CONTROLLED-CURRENT MODE

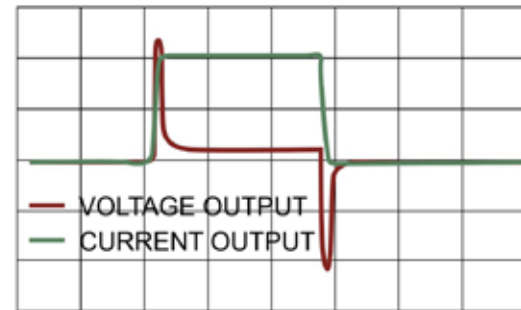

Figure 6.14 – Input to Output Comparison, Controlled-Current Operation

6.3.2 Safety and Operation Considerations for Controlled Current Operation

When an AE Techron amplifier is configured as a Controlled-Current source, care needs to be exercised in its operation. **Any voltage controlled current source should never be turned on without a load, (with some impedance, real or effective) connected to its output terminals.** When asked to operate in this way, any current source (including an AE Techron amplifier) will increase its output voltage in an attempt to drive the requested current into the load. In an open-circuit condition, creating current flow will be impossible. The current source will increase its output voltage until it reaches its voltage limit. This is a potentially dangerous condition for both the AE Techron amplifier and for any user who might come in contact with the amplifier output terminals.

When operating in Controlled-Current (CC) mode, a compensation circuit is required to ensure accurate output current. Since the load is a critical circuit component in CC mode, the inductive and resistive values of the load will determine the required compensation values. While the factory-default compensation setting will be sufficient for some applications, the compensation setting may also be adjusted in the field. The following section describes methods for determining and setting proper compensation when operating in Controlled-Current mode.

6.3.3 Controlling Compensation for CC Operation

AE Techron 7234 amplifiers can be configured for either Controlled Voltage (CV) or Controlled Current (CC) mode of operation. When operating the amplifier in Controlled Voltage (CV) mode, compensation is not required. However, when operating in Controlled Current (CC) mode, the amplifier load becomes an integral part of the system. In order to ensure system stability and to control available bandwidth, compensation via an RC network is required for CC operation. The following steps will allow you to compensate your amplifier for operation in CC mode safely and effectively.

STEP 1: Check Amplifier Operation in CV mode.

We recommend that you power-up and enable the amplifier in Controlled Voltage mode without attaching a load before configuring your amplifier for Controlled Current operation. This will allow you to verify that the input signal and the amplifier are operating correctly.

Once this initial check is completed, power down the amplifier, attach your load, and move the back-panel Operation (CV/CC) DIP switch (SW#1) to the DOWN position to place the amplifier in CC mode. **IMPORTANT:** Make sure the back panel **Compensation (CC1/CC2)** DIP switch (SW#2) is in the **UP** position to enable the factory-default

compensation network. See **Figure 6.15**. Refer to the **Advanced Configuration** section for more information.

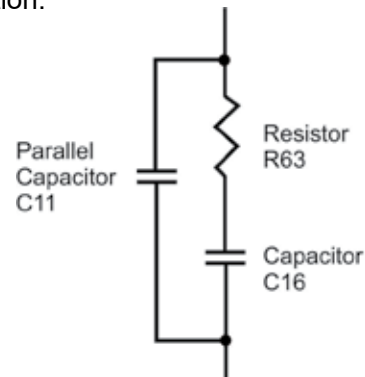

Figure 6.15 – Factory-installed Default RC Network

STEP 2: Determine Required Compensation.

When operating an amplifier in Controlled-Current mode, the load becomes an integral part of the system. In order to determine the required compensation for your load, begin by consulting the following table to determine the approximate

compensation capacitance (C) required based on the inductance of your load. Note that these calculations are based on empirical measurements and are approximate.

	Load Inductance (L)		
	<200 μ H	<>200 μ H – <1 mH	>1 mH
Compensation Capacitance (CC)	0.001 μ F	0.01 μ F	0.1 μ F

NOTE: Load Resistance (R) is assumed to be <5 ohms.

STEP 3: Determine if Default or Custom Compensation is Required.

If your load inductance is between 200 microHenries and 1 milliHenry, and your load resistance is less than 5 ohms, then you can likely use the default compensation provided by the amplifier's factory-installed RC network.

If your load inductance falls outside of the mid-range, or if your load resistance is greater than

5 ohms, then you must calculate your required compensation. If, after calculating your required compensation, you determine that the default compensation will be insufficient for your load, then you will need to calculate and then enable and install a custom RC network. See **STEP 5** below.

STEP 4: (Optional) Verify Suitability of Default Compensation (CC1)

If desired, the following values of the components contained in the default RC network can be used with the formulas provided in **STEP 5** below to verify the suitability of the default compensation for your uses.

Compensation Resistor: 68.1k ohms

Compensation Capacitor: 47 nF

Parallel Capacitor: 100 pF

STEP 5: Calculating Values for an RC Network for Custom Compensation

If the default RC network does not provide suitable compensation for your intended load, you will need to install a custom RC network that is matched to your load. This network will require two components (a resistor (R) and a capacitor (C)) to be installed on the amplifier's main board. To calculate the approximate values required for each component, use the following formulas.

COMPENSATION FORMULAS:

To find the value for the resistor (Rc) in the RC network: **$R_c = 20,000 \times 3.14 \times L \times BW$**

where:

Rc is compensation resistance in ohms.

L is load inductance in henries.

BW is bandwidth in hertz.

To find the value for the capacitor (Cc) in the RC network: **$C_c = L / (R \times R_c)$**

where:

Cc is compensation capacitance in farads.

L is load inductance in henries.

R is resistance of load in ohms.

Rc is compensation resistance in ohms.

STEP 6: Installing and Enabling the Custom RC Network

Once an approximate Rc and Cc have been computed, these values will need to be evaluated. To do this, you will need to install the custom components on the amplifier's main board and enable the alternate compensation network (CC2).

The main board can be accessed by removing the amplifier top cover. To remove the amplifier top cover, complete the steps detailed in the following section.

Amplifier Top Cover Removal

Tool Required

#2 Phillips screwdriver

⚠ DANGER

Uninsulated terminals with AC mains potential are exposed when the top cover is removed. Do not proceed until the amplifier has been turned off and the AC Mains has been disconnected.

⚠ CAUTION

After turning the amplifier off, let the unit sit for 3-5 minutes before removing the top cover. This will allow the electrical charge in the power supply capacitors to discharge.

4. Lift the cover straight up to remove it and set it aside.
5. To replace the top cover, slide the cover in to place on the amplifier and replace the nine screws.
6. Position the grill near the front panel and snap into place.

⚠ CAUTION

The front grill is held on by strong magnets. When replacing the front grill, hold the grill by its side edges and be sure to keep fingers clear of the grill back. Pinching injuries can occur if the grill is replaced improperly.

Procedure

1. Remove power from the amplifier and disconnect any load from the amplifier outputs. Wait a minimum of three minutes to allow the amplifier's capacitors to discharge.
2. Remove the amplifier's front grill cover by firmly pulling the grill cover away from the front panel. The grill is held by magnets.
3. Use the Phillips screwdriver to remove nine (9) screws:
 - a. Three (3) screws from each side
 - b. One (1) screw from the back
 - c. Two (2) screws from the front (after the grill cover is removed).

Custom Compensation Network Installation

When the 7234 amplifier is used in Controlled-Current mode, the current control loop is tuned with an RC network. The factory default network (CC1) provides 68.1k ohm resistance and 47 nF capacitance. If this default network is not adequate for your application and load, CC2 can be used to install a custom RC network on the amplifier main board.

First, install components with the required values in the main board at locations **R5** and **C2** as shown in **Figure 6.16**.

To change the compensation network: First, make



Figure 6.16 – Custom Compensation Component Locations

sure the amplifier is turned OFF. Then, locate back panel **Compensation (CC1/CC2)** DIP switch

(SW#2). Move the switch to the **Down** position to enable the path to the custom network (CC2).

STEP 7: Optimizing the Compensation Values.

Remember the load you are connecting is a part of the system and the amplifier should not be turned on without the load being connected.

After installing the components, check to ensure that the Operation DIP switch (SW#1) is set to Current mode, then power up the amplifier without signal input.

To begin testing, input a square wave with a frequency of 100 Hz to 1 kHz, or a squared pulse at a low level (typically 0.25 to 2.0 volts). A limited-rise-time, repetitive pulse of low duty cycle is preferred.

Observe the output current through a current monitor or current probe. Look for clean transition edges. The presence of ringing or rounding on the transition edges indicates compensation problems. (See **Figure 6.17.**)

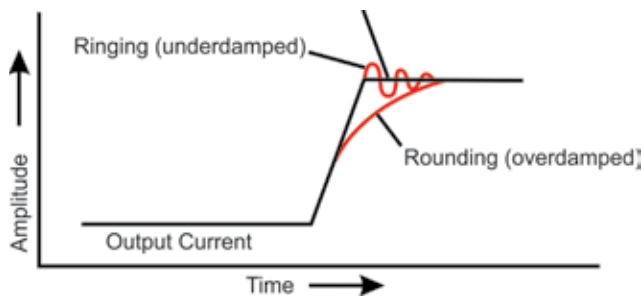

Figure 6.17 – Compensation Effects on Waveform

If a change in compensation is necessary, an adjustment to the resistor component of the Compensation circuit is probably required.

If the output current waveform is ringing, the circuit is underdamped: You have too much compensation and should lower the resistance (see **Figure 6.18.**)

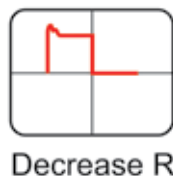

Figure 6.18 – Square Wave Showing a Decrease in R is Required

If the output current waveform is rounded, the circuit is overdamped: You have too little compensation and should increase resistance (see **Figure 6.19.**)

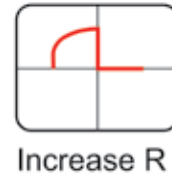

Figure 6.19 – Square Wave Showing an Increase in R is Required

If the output current waveform is neither underdamped or overdamped, but the top of the squarewave is not level, then you should instead decrease the capacitor value (see **Figure 6.20.**)

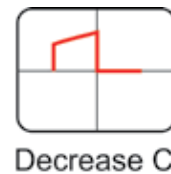

Figure 6.20 – Square Wave Showing a Decrease in C is Required

When making adjustments:

Resistor: Increase or decrease resistance values in increments of +/- 10%.

Capacitor: Incrementally decrease capacitor values by a factor of 2 or 3.

After final adjustments have been made to the circuit, the final waveform for your planned application should be tested to confirm the amplifier's compensation setting.

NOTE:

- If possible, use 1% metal film resistors. AE Techron discourages installation of potentiometers in the resistor location of the compensation circuit because this can decrease stability and may increase inductance.
- The parallel capacitor in the RC network serves to increase stability but can be removed, if it is not required for system stability. If the parallel

capacitor is used, it will usually decrease the value of resistance needed.

- In multiple amplifier systems, expect to decrease the value of R5 in series systems by 1/2.

6.4 Multi-amp Systems for Increased Voltage or Current

The 7234 amplifier may be used with other 7234 amplifiers to increase voltage or current. Because the internal circuitry of a 7234 amplifier is not connected to chassis ground, the amplifier is well suited for use in series or parallel with other 7234 amplifiers.

7234 multi-amplifier configurations include: Push/Pull, Series, or Parallel. Two 7234 amplifiers can be wired in a Push/Pull configuration for approximately double the output voltage. Up to three 7234 amplifiers may be configured in series for up to three times the continuous output voltage. Up to four 7234 amplifiers may be configured in parallel for up to four times the continuous current output. See **Figure 6.21** for the approximate output levels you can expect from each multi-amp system.

CONFIGURATION	CONTINUOUS OUTPUT (100% Duty Cycle)
Push/Pull	316 Vp
Two in Series	316 Vp
Three in Series	474 Vp
Two in Parallel	90 Ap
Three in Parallel	135 Ap
Four in Parallel	180 AP

Figure 6.21 – Typical Output Levels for 7234 Multiamp Systems

While it is possible to operate a multi-amp system in either Controlled Voltage or Controlled Current modes of operation, multi-amp operation in Controlled Current mode requires additional configuration of the equipment. Please contact **AE Techron Tech Support** for assistance with configuring a multi-amp system for Controlled Current operation.

Configurations with more amplifiers in series or parallel, and combination series/parallel systems may be possible, depending on the application.

For more information on these complex multi-amp systems or for assistance in determining the best multi-amp configuration to meet your requirements, please contact **AE Techron Application Support**.

For routine, Controlled-Voltage applications, Push/Pull, Series, or Parallel amplifier systems can be configured using standard 7234 amplifiers and the following accessories available from AE Techron:

Push/Pull Systems:

7234 Push/Pull DB9 Cable (part number 69-8005917)

Parallel Systems:

7234 Parallel Wiring Kit (2-amp) (part number 69-8005918)

7234 Parallel Wiring Kit (3-amp) (part number 69-8005919)

7234 Parallel Wiring Kit (4-amp) (part number 69-8005920)

Series Systems:

SIM-BNC-OPTOC (part number 69-1875020)

DB9M Series Cable (part number 69-8002516)

Please contact AE Techron's **Sales Department** for more information.

6.4.1 Multiamp Safety Principles

Following these basic principles will help to ensure the safety of your equipment and personnel.

One Master Amplifier

Typical multiamp configurations require one amplifier configured as a Master amplifier, and all other amplifiers in the system configured as Follower amplifiers. Do not operate with more than one Master in your multiamp system unless instructed by AE Techron Technical Support.

Use Only 7234 Amplifiers

Use only AE Techron 7234 amplifiers to construct a 7234 multiamp system. Do not combine different models of AE Techron amplifiers in the same system or use amplifiers made by another manufacturer in a 7234 multiamp system. Such improper connections could damage the amplifiers.

Use Correct Wiring

Never directly connect one amplifier's OUTPUT terminal to another amplifier's OUTPUT terminal. The resulting circulating currents will waste power and may damage the amplifiers. Depending on the configuration to be used, the OUTPUT terminal of one amplifier should only be directly connected to the next amplifier's COM terminal or to the load.

Operate with Safety in Mind

Potentially lethal voltages and currents are present within the 7234 amplifiers. While the amplifiers' chassis are earth-grounded, **all internal grounds are floating**. Particularly in series systems, all internal grounds of **Follower amplifiers could carry lethal voltages**.

6.4.2 Configuration and Wiring for Push/Pull Operation

To configure and connect two amplifiers for operation in a push/pull configuration, begin by designating one amplifier as the Master amplifier, and the other amplifier as the Follower amplifier. Consider placing a "Master" or "Follower" label on each amplifier's back panel to clarify the amplifier designation during setup and operation.

Make sure both amplifiers are disconnected from AC power.

Required DIP Switch Settings

DIP switch settings required for Push/Pull operation are shown in **red** in **Figure 6.22**. Configure these back-panel DIP switches for both Master and Follower amplifiers.

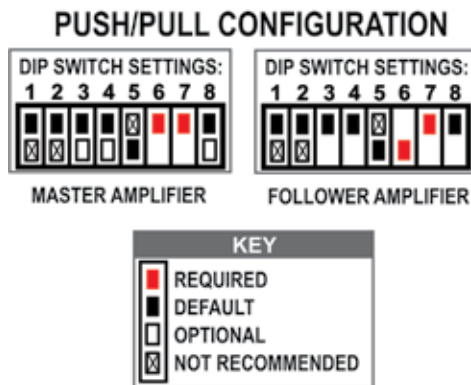

Figure 6.22 – DIP Switch Settings for Push/Pull Configuration

Optional DIP Switch Settings

DIP switches 3, 4 and 8 control amplifier functions that can be optionally enabled for use during multi-amp operation. The Master amplifier controls these functions for the multi-amp system, so you only need to adjust these settings on the Master amplifier.



SW#3 - Low-Pass Filter (50 kHz): Set DIP switch #3 on the Master amplifier in the DOWN position to enable.

SW#4 - Gain (20 / 6): Set DIP switch #4 on the Master amplifier in the DOWN position to change the system gain to 6..

SW#8 - DC/AC Coupling: Set DIP switch #8 on the Master amplifier in the DOWN position to block DC signals.

Amplifier Wiring

Refer to **Figure 6.23** and make the following connections to the Master and Follower amplifiers.

1. Connect the DB9 cable from the 7234 Push/Pull Cable Kit (part number 69-8005917) from the back-panel Interconnect B Port on the Master amplifier to the Interconnect A Port on the Follower amplifier.
2. Connect from a signal generator to the BNC or WECO signal input connector on the Master amplifier's back panel SIM-BNC input card.
3. Using wiring appropriate for your application, connect from the Master amplifier's back-panel SAMPLED COMMON connector to the Follower amplifier's back-panel SAMPLED COMMON connector.

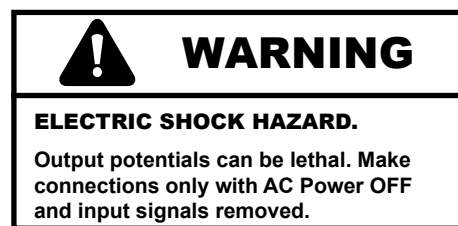

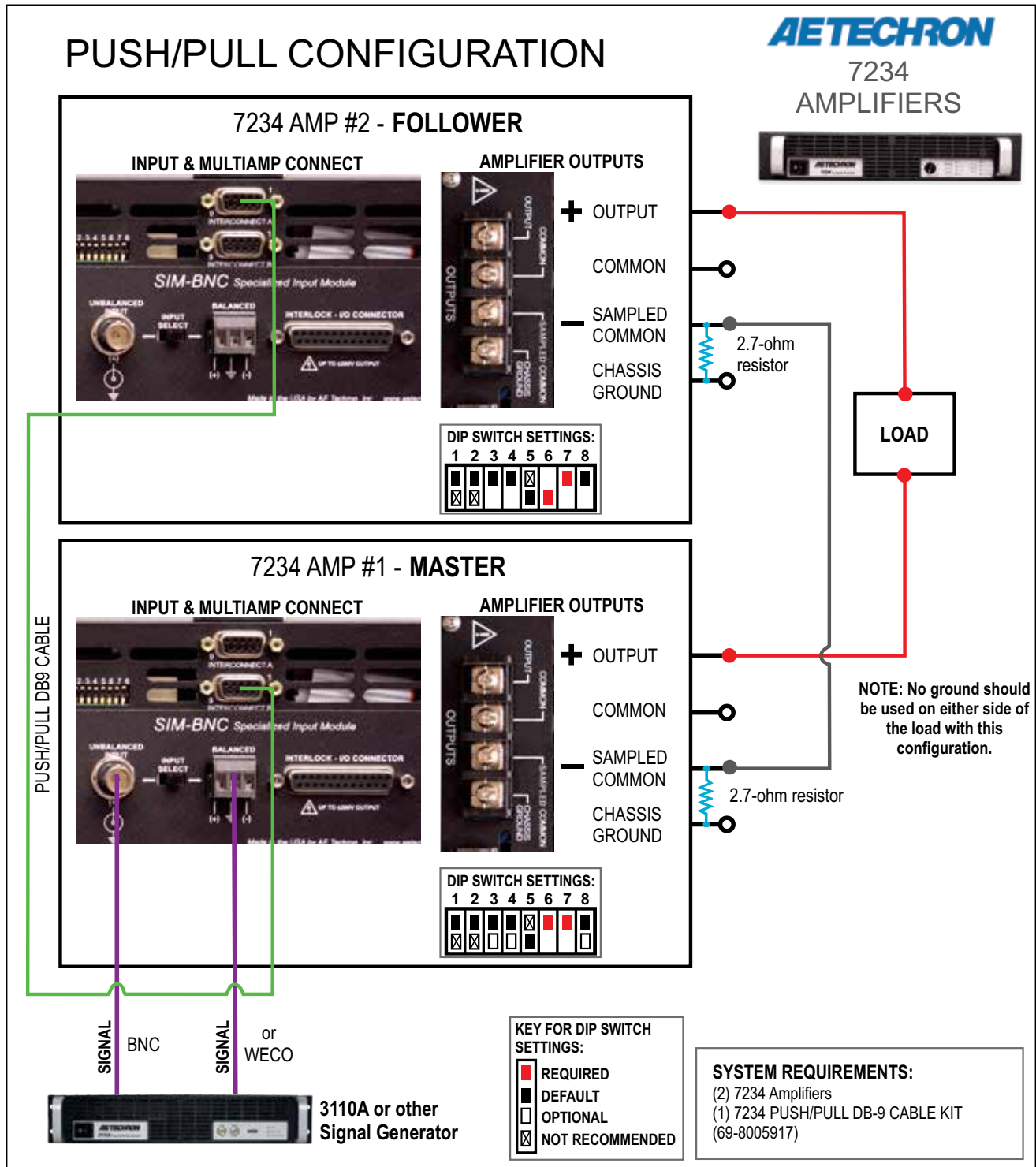

Figure 6.23 – Configuration and Wiring for Push/Pull Operation

4. Using wiring appropriate for your application and your load, connect from the Master and Follower amplifiers' OUTPUT connectors to the load

6.4.3 Configuration and Wiring for Parallel Operation

To configure and connect up to four 7234 amplifiers for operation in a parallel configuration, begin by designating one amplifier as the Master amplifier. Up to four 7234 amplifiers can be configured

for parallel operation, so all other amplifiers in the system will operate as Follower amplifiers. Consider placing labels on each amplifier's back panel to clarify the amplifier designation during setup and operation (Master, Follower #1, Follower #2, etc.).

Make sure all amplifiers are disconnected from AC power.

Required DIP Switch Settings

DIP switch settings required for Parallel operation are shown in red in **Figure 6.24**. Configure these back-panel DIP switches for the Master and all Follower amplifiers.



Optional DIP Switch Settings

DIP switches 3, 4 and 8 control amplifier functions that can be optionally enabled for use during multi-amp operation. The Master amplifier controls these functions for the multi-amp system, so you only need to adjust these settings on the Master amplifier.

SW#3 - Low-Pass Filter (50 kHz): Set DIP switch #3 on the Master amplifier in the DOWN position to enable.

SW#4 - Gain (20 / 6): Set DIP switch #4 on the Master amplifier in the DOWN position to change the system gain to 6..

SW#8 - DC/AC Coupling: Set DIP switch #8 on the Master amplifier in the DOWN position to block DC signals.

Amplifier Wiring

Refer to **Figure 6.25** and make the following connections to the Master and Follower amplifiers.

1. Connect a Parallel DB9 cable from the 7234 Parallel Wiring Kit (2-Amp: part number 69-8005918; 3-Amp: part number 69-8005919; 4-Amp: part number 69-8005920) from the back-panel Interconnect B port on the Master amplifier to the Interconnect A port on the first Follower amplifier (Follower #1).

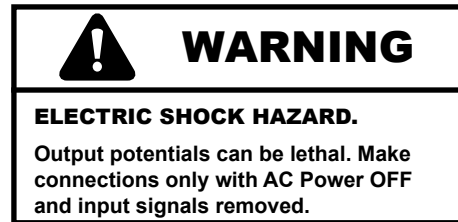

2. If additional Follower amplifiers are to be used, connect an additional Parallel DB9 cable from the back-panel Interconnect B port on Follower #1 amplifier to the Interconnect A port on the second Follower amplifier (Follower #2). Repeat this set with an additional Parallel DB9 cable for the third Follower amplifier, if used.
3. Connect from a signal generator to the BNC or WECO signal input connector on the Master amplifier's back panel SIM-BNC input card.
4. Using the red and black output cables from the **7234 Parallel Wiring Kit**, connect one cable leg of the black (ground) output cable to each of the amplifier's back-panel SAMPLED COMMON connectors, and then connect the cable's terminated end to the ground terminal of your load. Next, connect one cable leg of the red (positive) output cable to each of the amplifier's back-panel OUTPUT connectors, and then connect the cable's terminated end to the positive terminal of your load.

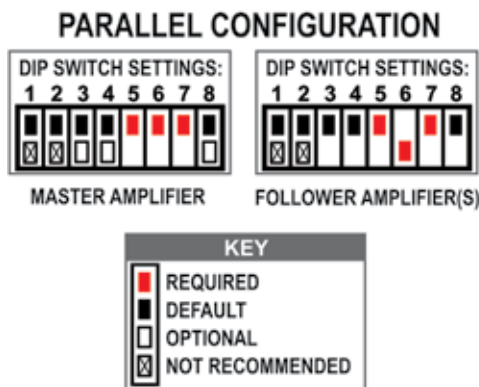

Figure 6.24 – DIP Switch Settings for Parallel Configuration

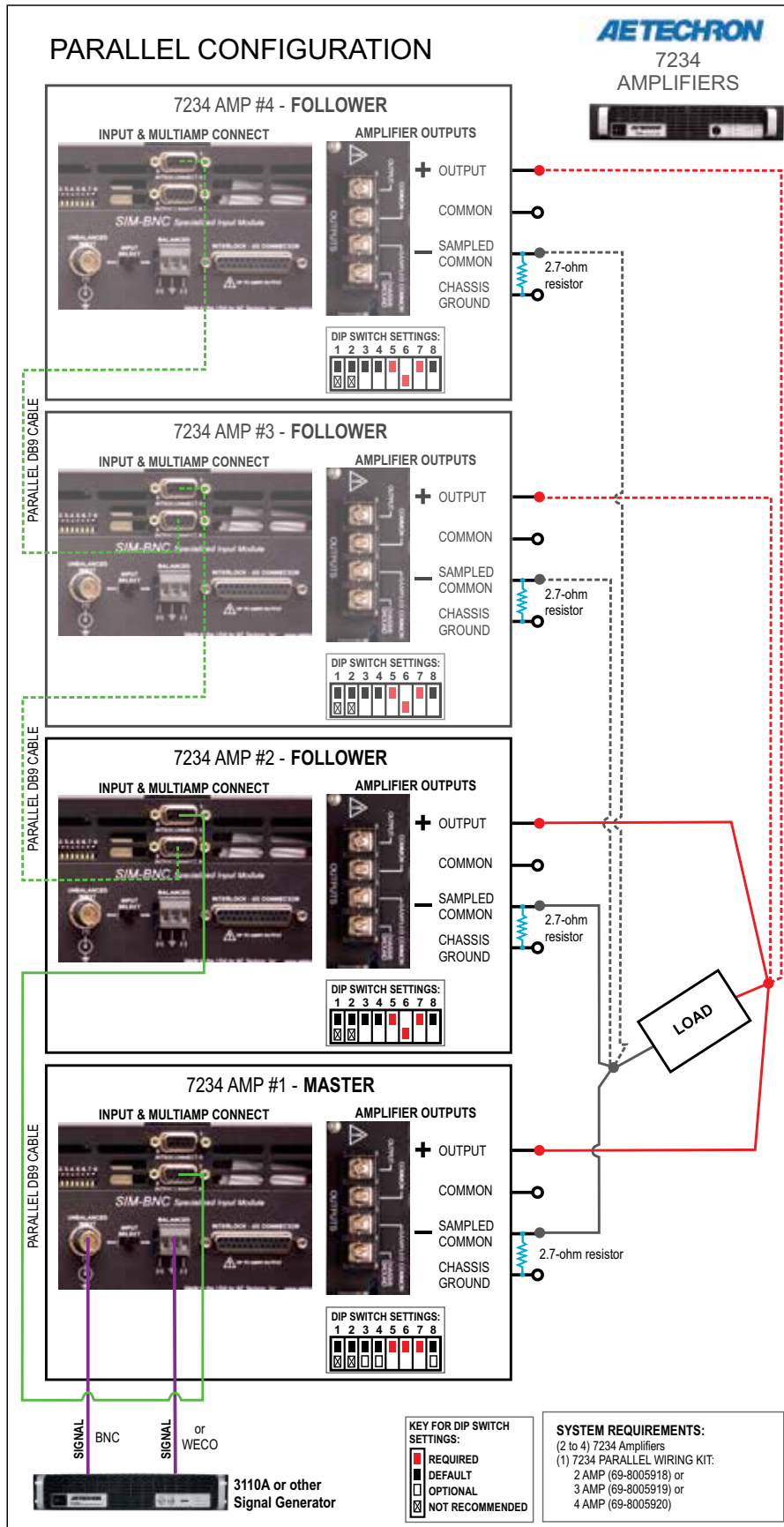

Figure 6.25 – Configuration and Wiring for Parallel Operation

6.4.4 Series Configuration

To configure and connect up to three amplifiers for operation in a series configuration, begin by designating one amplifier as the Master amplifier. Up to three 7234 amplifiers can be configured for series operation, so all other amplifiers in the system will operate as Follower amplifiers. Consider placing labels on each amplifier's back panel to clarify the amplifier designation during setup and operation (Master, Follower #1, Follower #2).

Make sure all amplifiers are disconnected from AC power.

Required DIP Switch Settings

DIP switch settings required for Parallel operation are shown in red in Figure 6.26. Configure these back-panel DIP switches for the Master and all Follower amplifiers.



CAUTION

Turn the amplifier OFF before changing DIP switch positions. Some switch changes could result in amplifier damage.

Optional DIP Switch Settings

DIP switches 3, 4 and 8 control amplifier functions that can be optionally enabled for use during multi-amp operation. The Master amplifier controls these functions for the multi-amp system, so you only need to adjust these settings on the Master amplifier.

SW#3 - Low-Pass Filter (50 kHz): Set DIP switch #3 on the Master amplifier in the DOWN position to enable.

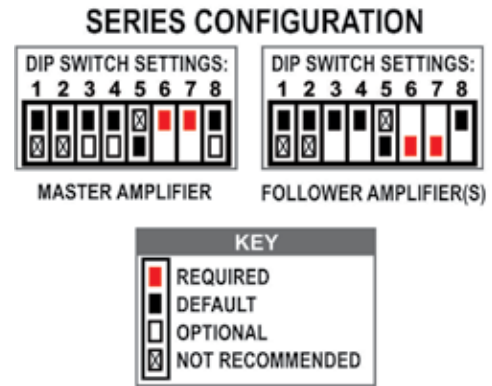

Figure 6.26 – DIP Switch Settings for Series Configuration

SW#4 - Gain (20 / 6): Set DIP switch #4 on the Master amplifier in the DOWN position to change the system gain to 6..

SW#8 - DC/AC Coupling: Set DIP switch #8 on the Master amplifier in the DOWN position to block DC signals.

Configure SIM-BNC-OPTOC cards

Each amplifier in a 7234 Series multi-amp system uses a specialized input card (SIM-BNC-OPTOC) that helps to synchronize the operation of all amps in the system and provides for optical isolation. The input card allows you to designate (via jumpers located on the card), that the input card will function as a Master or a Follower.

If desired, you can also configure the WECO input connector on the SIM-BNC-OPTOC card to be used as an unbalanced input via jumpers located on the input card.

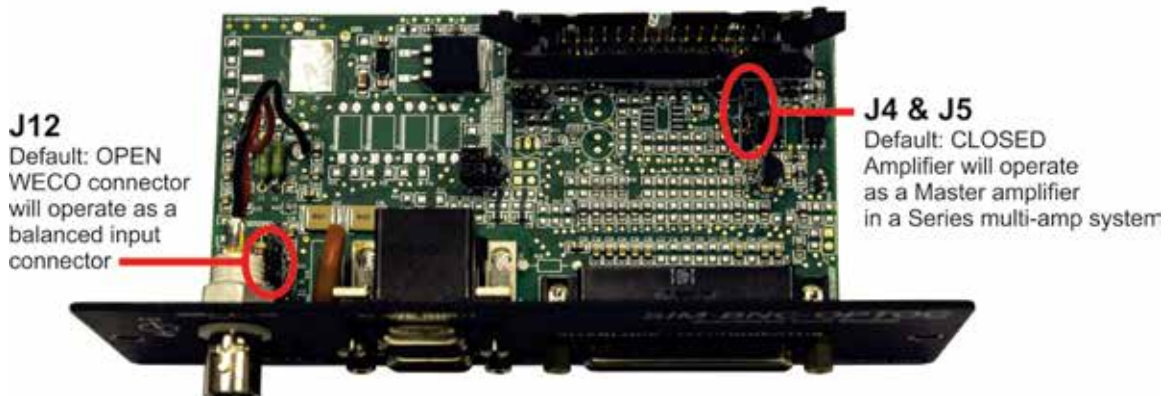

Figure 6.27 – SIM-BNC-OPTOC jumper locations

Jumper locations for the SIM-BNC-OPTOC card are shown in **Figure 6.27**.

Jumpers 4 & 5: When J4 and J5 are Closed, the input card is configured to function in an amplifier that will act as a Single amplifier, or as a Master amplifier in a multi-amplifier system. When J4 and J5 are Open, the input card is configured to function in an amplifier that will act as a Follower in a multi-amplifier system. **Factory default:** Closed.

Jumper Configuration: For all except one SIM-BNC OPTOC input cards, remove the shunts from Jumpers 4 and 5 to configure the cards to function as Followers. Place a label reading “Master” or “Follower” on the front of each input card to clarify the function of each card.

Jumper J12: When Open, this option lifts the negative (–) leg from ground on both input connectors, allowing the WECO connector to be used as a balanced input and the BNC connector to be used as an unbalanced floating input. When Closed, the negative (–) leg is tied to ground through a 2.7-ohm resistor, allowing either the BNC or the Removable Barrier Block connector to be used as an unbalanced grounded input. **Figure 6.28** details the input connectors' internal wiring. **Factory default:** Open.

Jumper Configuration: To configure the WECO input to be used as an unbalanced input, place a shunt at Jumper J12 on the Master input card only.

Install SIM-BNC-OPTOC cards in Amplifiers

Before preparing the amplifiers, make sure the amplifier is turned off for at least 3-5 minutes and the AC mains are disconnected.

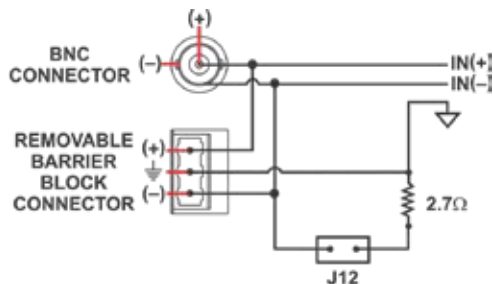
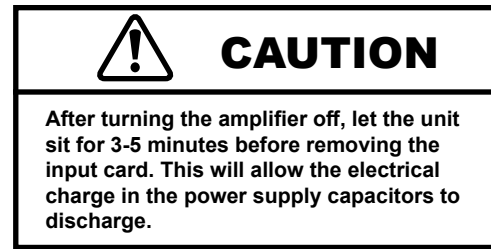

Figure 6.28 – SIM-BNC-OPTOC input connectors' internal wiring



1. Locate the standard SIM-BNC Input Card on the right side of the rear panel of each amplifier.
2. Use a #2 Phillips screwdriver to remove and retain the two (2) screws located at the edges of the input card.
3. Unplug the ribbon cable from the back of the input card; remove the card from the amplifier card bay.
4. For each amplifier, plug the ribbon cable into the ribbon connector on the SIM-BNC-OPTOC card. Reinstall the card into the card bay on the amplifier back panel and secure in place using the retained screws.

Remove 2.7-ohm Resistors from Follower Outputs

Use a #1 Phillips screwdriver to remove the 2.7-ohm resistor on the amplifier output connectors from all amplifiers that will be operating as Follower amplifiers. See **Figure 6.29**. **IMPORTANT: These resistors must be removed before operating your Series system to avoid potential product failure.**



Figure 6.29 – Remove the 2.7-ohm resistor from Follower amplifiers

Amplifier Wiring

Refer to **Figure 6.30** or **6.31** and make the following connections to the Master and Follower amplifiers.

1. Connect the DB9M Series Cable (part number 69-8004125) from the MASTER OUTPUT connector on the Master amplifier's SIM-BNC-OPTOC card to the SLAVE INPUT connector on the first Follower amplifier's SIM-BNC-OPTOC card.
2. Connect from a signal generator to the BNC or WECO signal input connector on the Master amplifier's back panel SIM-BNC-OPTOC input card.
3. Using wiring appropriate for your application, connect from the Master amplifier's back-panel OUTPUT connector to the first Follower amplifier's back-panel SAMPLED COMMON connector.

4. For a three amplifier system, connect from the first Follower amplifier's back-panel OUTPUT connector to the second Follower amplifier's back-panel SAMPLED COMMON connector.
5. Using wiring appropriate for your application and your load, connect from the first (or second, if a three amplifier system) Follower amplifier's OUTPUT connector to the load's positive terminal.
6. Connect from the load's negative terminal to the Master amplifier's SAMPLED COMMON connector.

6.4.5 Multiamp System Start-up Procedure

1. Turn down the level of your signal source.
2. Make sure the Gain Control on both amplifiers is turned fully clockwise (100%).

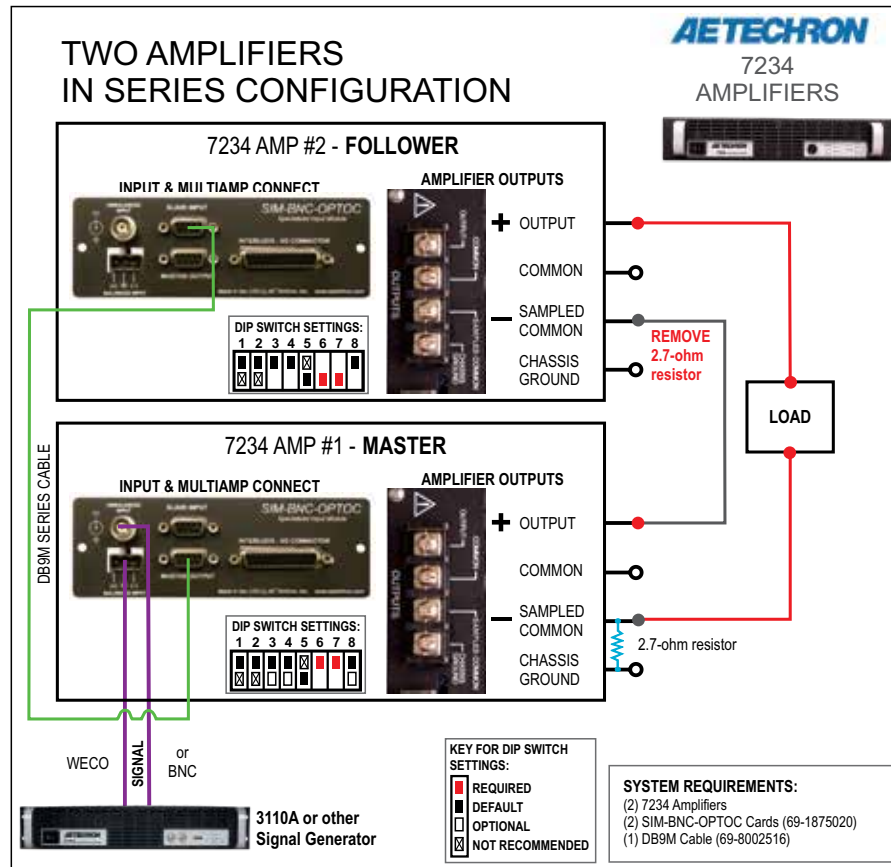

Figure 6.30 – Configuration and Wiring of Two Amplifiers for Series Operation

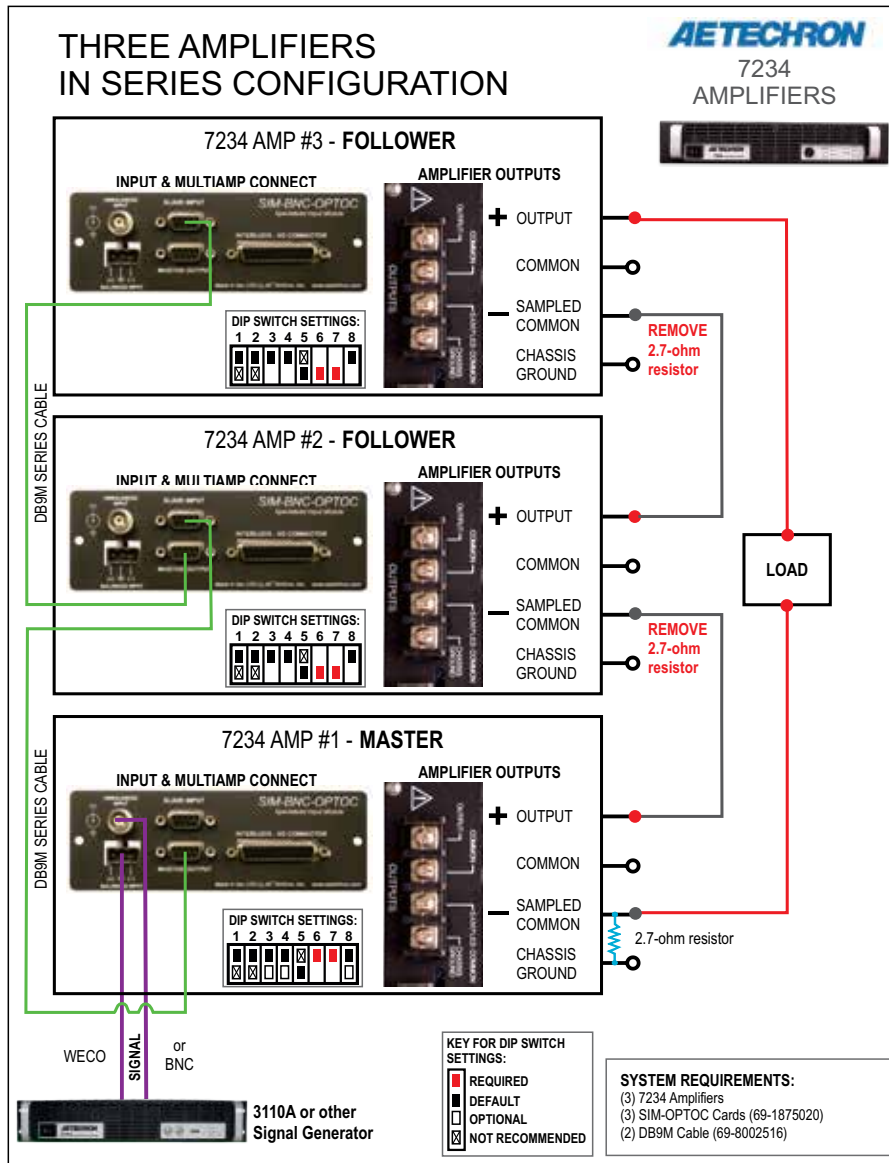

Figure 6.30 – Configuration and Wiring of Three Amplifiers for Series Operation

- Depress the POWER switches on both the Master and the Follower amplifiers (in any order) to turn the power ON.
- Wait for the yellow READY and green RUN LEDs to illuminate on both amplifiers.
- Adjust the input signal level to achieve the desired output level.

6.4.6 Multiamp System Operation

In multiamp systems, the Master amplifier controls several operating functions for all amplifiers included in the system, so Follower amplifiers are said to be “interlocked” with the Master amplifier.

The functions controlled by the Master amplifier include input signal, operating status, low-pass filter, gain, AC/DC coupling, mode of operation (controlled-voltage or controlled-current operation) and amplifier compensation.

Because the amplifiers in a multiamp system are interlocked, the main and fault status indicators of all amplifiers in the system must be considered to determine the current status and the necessary remedies to return the system to operational status when a fault condition occurs.

Enable, Stop and Reset Buttons

The following details the results when each of the three Push Buttons are pressed on an amplifier front panel in a multi-amp system.

Enable – In multi-amp systems that have been configured to start up in Run mode (factory default setting), when an amplifier is powered on, the amplifier will be placed in Remote Standby mode (Ready and Standby LEDs lit) and remain in Remote Standby mode until all amplifiers in the system have been powered on. The system will automatically proceed to Run mode when all amplifiers in the system are powered on and achieve Remote Standby mode.

In multi-amp systems that have been configured to start up in Stop mode, when an amplifier is powered on, the amplifier will be placed in Standby/Stop mode (Stop and Standby LEDs lit). When the Enable button is pressed on each amplifier, that amplifier will be placed in Remote Standby mode (Ready and Standby LEDs lit) and remain in Remote Standby mode until all amplifiers in the system have been Enabled. The system will automatically proceed to Run mode when all amplifiers in the system achieve Remote Standby mode.

Stop – Pressing the Stop button on any amplifier in the system will place that amplifier in Standby/Stop mode and place all other amplifiers in the system in Remote Standby mode.

Reset – Pressing the Reset button on the amplifier reporting a fault condition will return all of the amplifiers to Run mode if the condition causing the fault condition has been cleared and the amplifier has been configured for startup in Run mode. However, pressing the Reset button on other amplifiers in the system (not reporting a fault condition) will NOT clear the fault condition. Refer to the

“Fault Status Indicators” section for information on how to clear fault conditions and restore amplifier operation.

If the amplifier reporting the fault condition has been configured for startup in Stop mode, pressing the Reset button will place the amplifier in Standby/Stop mode. Press the Enable button to return the amplifier system to Run mode.

Main Status Indicators for Multi-amplifier Systems

The Main Status indicators on each amplifier in a multi-amp system are used to determine the operational status of the amplifier. When evaluated along with the statuses of other amplifiers in the system, the Main Status indicators can be used to determine the system status and the action required to return the system to Run mode. See **Figure 6.31**.

Fault Status Indicators for Multi-Amp Systems

The four Fault Status indicators located on each amplifier's front panel are used to monitor the internal conditions of the amplifier and will illuminate when a fault condition occurs. All amplifiers in the system may be placed in Standby mode when a fault condition occurs, depending on the fault condition and the configuration of the system. Typically, the system can be released from Standby mode by pressing the Reset button on the amplifier displaying the Fault status. Refer to the chart in **Figure 6.32** to determine the fault condition being indicated and the action required to clear the fault condition and return the system to Run mode.

Figure 6.31 – Main Status Indicators for Multi-Amplifier Systems

● ● ● Indicator is lit ● Indicator is not lit ○ Indicator may be lit

Main Status of One or More Amps in the System	Main Status of Other Amps in the System	State of Operation	Action Needed to Return to Run Mode
<ul style="list-style-type: none"> ● Run ● Ready ● Standby ● Stop 	<ul style="list-style-type: none"> ● Run ● Ready ● Standby ● Stop 	<p>Run mode: All of the amplifiers in the system are in Run mode. The amplifiers' high-voltage transformers are energized and the system will amplify the input signal.</p>	N/A
<ul style="list-style-type: none"> ● Run ● Ready ● Standby ● Stop 	<ul style="list-style-type: none"> ● Run ● Ready ● Standby ● Stop 	<p>Remote Standby mode: All of the amplifiers in the system are being held in Standby mode by an external condition. In Standby mode, the amplifiers' low-voltage transformers are energized but the high-voltage transformers are not.</p>	<p>If the amplifiers remain in Standby mode, the system is being held in Standby by remote control through one of the Interconnect ports or the SIM Interlock I/O connector. Activate the Standby switch to clear this remote Standby condition and return the system to Run mode. See the topic <i>“Remote Status and Control Using the Interconnect Ports”</i> and <i>“Remote Status and Control Using the Interlock I/O Connector”</i> in the Applications section of this manual for more information on remote amplifier operation.</p>
<ul style="list-style-type: none"> ● Run ● Ready ● Standby ● Stop 	<ul style="list-style-type: none"> ● Run ● Ready ● Standby ● Stop 	<p>System Not Ready: If one or more of the amplifiers has no LEDs lit, the amplifier has no power or has not been turned on, and the other amplifiers in the system will be held in Remote Standby mode. In Remote Standby mode, the amplifier's low-voltage transformer is energized but the high-voltage transformers are not.</p>	<p>Make sure all amplifiers have AC power and have been turned on. When all amplifiers attain Standby status, all amplifiers in the system will simultaneously be placed in Run mode.</p>
<ul style="list-style-type: none"> ● Run ● Ready ● Standby ● Stop 	<ul style="list-style-type: none"> ● Run ● Ready ● Standby ● Stop 	<p>Standby/Stop mode: When the Stop button on any amplifier in the system is pressed, that amplifier will enter Stop mode and all other amplifiers will enter Remote Standby mode. The system may also enter Stop mode after powering up if one or more amplifiers in the system is configured to enter Stop mode on startup. In Stop mode, the amplifier's low-voltage transformer is energized but the high-voltage transformers are not.</p>	<p>To release the system from Standby/Stop mode, press the Enable button on the amplifier displaying the Stop mode status.</p>

Figure 6.32 – Fault Status Indicators for Multi-Amplifier Systems

● ● ● Indicator is lit ● Indicator is not lit ○ Indicator may be lit

One or More Amps in System		Other Amps in System		State of Operation	Action Needed to Clear Fault Condition and Return to Run Mode
Main Status Indicators	Fault Status Indicators	Main Status Indicators	Fault Status Indicators		
<ul style="list-style-type: none"> ● Run ● Ready ● Standby ● Stop 	<ul style="list-style-type: none"> ● Fault ● Over Load ● Over Temp ● Over Voltage 	<ul style="list-style-type: none"> ● Run ● Ready ● Standby ● Stop 	<ul style="list-style-type: none"> ● Fault ● Over Load ● Over Temp ● Over Voltage 	<p>Output Fault status: This indicates that an Output Fault condition has occurred in the amplifier displaying the Fault status, and the system has been placed in Standby mode. The Fault indicator will light under two conditions: 1) High-frequency oscillation is causing high shoot-through current; or 2) An output transistor has shorted, causing the output fault condition.</p>	<p>This fault condition cannot be cleared using the front-panel Reset button. See the “Troubleshooting” section for more information on diagnosing and clearing this fault condition.</p>
<ul style="list-style-type: none"> ● Run ● Ready ○ Standby ● Stop 	<ul style="list-style-type: none"> ● Fault ● Over Load ● Over Temp ● Over Voltage 	<ul style="list-style-type: none"> ● Run ○ Ready ○ Standby ● Stop 	<ul style="list-style-type: none"> ● Fault ● Over Load ● Over Temp ● Over Voltage 	<p>Over Load status: This indicates that the output of the system could not follow the input signal due to voltage or current limits. Under normal operation with the factory-default settings, an Over Load condition will not place the system in Standby mode. If the system has been configured to be forced to Standby on Over Load, the system will be placed in Standby mode when the Over Load indicator lights.</p>	<p>To remedy the Over Load fault during operation, turn down the level of the input signal until the Over Load indicator turns off. To clear an Over Load fault condition when the amplifier is forced to Standby, turn down the level of the input signal, then push the Reset button on the amplifier(s) displaying the Over Load status.</p>

One or More Amps in System		Other Amps in System		State of Operation	Action Needed to Clear Fault Condition and Return to Run Mode
Main Status Indicators	Fault Status Indicators	Main Status Indicators	Fault Status Indicators		
<ul style="list-style-type: none"> ● Run ● Ready ● Standby ● Stop 	<ul style="list-style-type: none"> ● Fault ● Over Load ○ Over Temp ● Over Voltage 	<ul style="list-style-type: none"> ● Run ● Ready ● Standby ● Stop 	<ul style="list-style-type: none"> ● Fault ● Over Load ● Over Temp ● Over Voltage 	<p>Over Temp status: Each amplifier in the system monitors the temperature inside the high-voltage transformers, low-voltage transformer and in the output stage heat sinks. The Over Temp indicator will light and the system will be placed in Standby mode when the temperature sensors detect a condition that would damage the amplifier system. If the Over Temp pulse is extremely short, as in the case of defective wiring or switches, the Over Temp LED may be lit too briefly to observe.</p>	<p>To reset after an Over Temp fault has occurred, make sure the amplifier fans in all amplifiers are running, and then remove the input signal from the system. Allow the fans to run for about 5 minutes, or until the amplifier has sufficiently cooled. Push and hold the Reset button on any amplifier displaying the Over Temp status until the Standby LED turns off, then release the Reset button to return the system to Run mode. Please see the Troubleshooting section for information on correcting the cause of an Over Temp fault condition.</p>
<ul style="list-style-type: none"> ● Run ● Ready ● Standby ● Stop 	<ul style="list-style-type: none"> ● Fault ● Over Load ● Over Temp ● Over Voltage 	<ul style="list-style-type: none"> ● Run ● Ready ● Standby ● Stop 	<ul style="list-style-type: none"> ● Fault ● Over Load ● Over Temp ● Over Voltage 	<p>Over Voltage status: This indicates that the AC mains voltage is more than +10% of nominal. All amplifiers in the system will be forced to Standby when an Over Voltage condition occurs. When the Over Voltage condition is cleared, the system will automatically return to Run mode.</p>	<p>To clear an Over Voltage fault condition, the AC mains must be brought down to the nominal value. If the system does not return to Run mode when the Over Voltage condition has cleared, one or more amplifiers may require servicing. Please see the Troubleshooting section for more information.</p>

7 Maintenance

Simple maintenance can be performed by the user to help keep the equipment operational. The following routine maintenance is designed to prevent problems before they occur. See the **Troubleshooting** section, for recommendations for restoring the equipment to operation after an error condition has occurred.

Preventative maintenance is recommended after the first 250 hours of operation, and every three months or 250 hours thereafter. If the equipment environment is dirty or dusty, preventative maintenance should be performed more frequently.

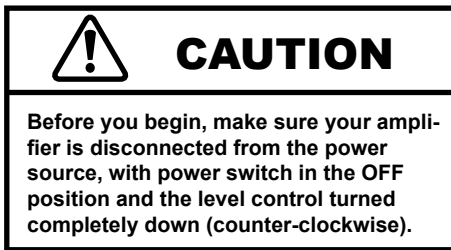

7.1 Clean Amplifier Filter and Grills

The recommended equipment and supplies needed to perform the functions required for this task are described in the following:

- Vacuum cleaner
- Damp cloth (use water only or a mild soap diluted in water)

To ensure adequate cooling and maximum efficiency of the internal cooling fans, the amplifier's front and rear grills should be cleaned periodically. To clean the amplifier grills and filter, complete the following steps:

1. Turn completely down (counter-clockwise) all level controls and turn the amplifier OFF. Disconnect the amplifier from its power source.
2. Using a vacuum cleaner, vacuum the front ventilation grill and the back ventilation exit grill.
3. Remove the front grill by pulling the grill firmly away from the amplifier.
4. Remove the filter and vacuum. You can also clean the filter using mild soap and water. **IMPORTANT:** Make sure the filter is completely dry before reinstalling in the amplifier.
5. Using a damp cloth, clean the front and rear ventilation grills. Dry with a clean cloth or allow to air dry. **IMPORTANT:** Grills should be completely dry before plugging in or restarting amplifier.
6. Reinstall the filter and replace the amplifier front grill.



8 Troubleshooting

8.1 Introduction & Precautions

This section provides a set of procedures for identifying and correcting problems with the 7234 amplifier. Rather than providing an exhaustive and detailed list of troubleshooting specifications, this section aims to provide a set of shortcuts intended to get an inoperative amplifier back in service as quickly as possible.

The procedures outlined in this section are directed toward an experienced electronic technician; it assumes that the technician has knowledge of typical electronic repair and test procedures.

Please be aware that the 7234 will undergo frequent engineering updates. As a result, modules and electronic assemblies may not be interchangeable between units. Particularly, the circuit boards undergo periodic engineering modifications that may make interchangeability between units impossible.

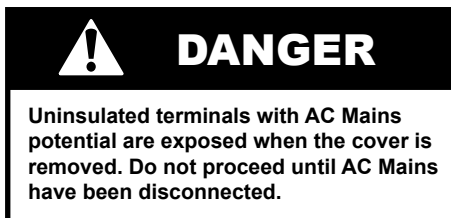

8.2 Visual Inspection

Before attempting to troubleshoot the amplifier while it is operating, please take time to complete a visual inspection of the internal components of the amplifier.

1. To perform a Visual Inspection, first turn the Breaker/Switch to the Off (O) position.
2. Disconnect the AC mains plug from the amplifier.
3. Wait three to five minutes for the Power Supply capacitors to discharge.
4. Inspect the amplifier's internal components. Check the following:
5. Inspect modules for charring, breaks, deformation or other signs of physical damage.

6. Look for any foreign objects lodged inside the unit.
7. Inspect the entire lengths of wires and ribbon cables for breaks or other physical damage.
8. If there is any physical damage to the amplifier, please return it to AE Techron for repair.

8.3 No Signal

Missing Output signal may be caused by one of the following:

1. The Master/Follower DIP switch (SW#6) is set to the Follower (Down) position. The amplifier should only be configured for Follower operation if it is in a multi-amplifier system; otherwise the Master/Follower DIP switch should be set to the Master (Up) position. See the **Advanced Configuration** section in this manual for more information.
2. Signal is not connected to any inputs on the SIM card. See the **Amplifier Setup** section in this manual for more information.

8.4 No LEDs Illuminated

If none of the LEDs on the Display Panel are illuminated, check the following:

1. The AC mains are not connected or not on (see the **Amplifier Setup** section for more information).
2. Front Panel Breaker/Switch has been tripped. Reset by turning the unit Off (O) and then On.

8.5 OverVoltage LED Lit

The amplifier will protect itself from AC mains voltage that is 10% above the voltage indicated on the back panel. If the AC mains voltage is more than 10% above the operating voltage, reduce the AC mains voltage to the proper level. When the line voltage condition is corrected, press the Reset button to return the amplifier to Run mode. If the amplifier does not reset, the amplifier's internal transformers may need to be replaced. Please see the **Factory Service** information at the end of this section.

8.6 Standby and Stop LEDs Remain Illuminated

A Remote Standby switch will cause the amplifier to enter Standby mode.

If the Interlock I/O port on the SIM card and/or one of the Interconnect ports is being used for remote control, the amplifier might be held in Remote Standby mode by another device. Release the remote switch or device to return the amplifier to Run mode. For more information on 7234 Remote Operation, see the **Applications** section in this manual.

8.7 Standby LED Remains Illuminated

The Standby indicator may remain illuminated under two conditions:

1. If the output wells or power transformer have overheated. If overheating is the problem, see the following topic (“Amplifier Overheats”).
2. If the connection to the Interlock I/O port or other input/output connections aren't fully secure. Check all wiring and connections.

8.8 Amplifier Overheats (Over Temp Fault Condition)

There are two possible reasons why the 7234 amplifier is overheating: Excessive power requirements or inadequate airflow.

8.8.1 Excessive Power Requirements

An amplifier will overheat if the required power exceeds the amplifier's capabilities. High duty cycles and low-impedance loads are especially prone to cause overheating. To see if excess power requirements are causing overheating, check the following:

1. The application's power requirements fall within the specifications of the amplifier. See the product's **Specifications Sheet**.
2. Faulty output connections and load.
3. Undesired DC offset at the Output and Input signal.

If the amplifier chronically overheats with suitable power/load conditions, then the amplifier may not

be receiving adequate airflow. To check for adequate airflow, proceed with the following steps:

8.8.2 Check for Inadequate Airflow

1. Check air filters. Over time they can become dirty and worn out. It is a good idea to clean the air filters periodically with a mild detergent and water.
2. Visually inspect fans to assure correct operation while amplifier is On (I). When an OverTemp fault occurs, the amplifier fans will automatically be placed in continuous high-speed operation. Any inoperative, visibly slow, or reverse-spinning fan should be replaced. Please see the Factory Service information at the end of this section.

An OverTemp condition places the amplifier in Standby mode. If the OverTemp pulse is extremely short, as in the case of defective wiring or switches, the OverTemp pulse may be too brief to observe.

8.8.3 Resetting After OverTemp

To reset the amplifier after an OverTemp has occurred, make sure fans are running. Remove the input signal from the amplifier and allow the fans to run for several minutes until the amplifier has cooled sufficiently. Then push the Reset button to reset the amplifier.

If the fault condition does not clear, return the amplifier for Factory Service.

8.9 Fault LED is Illuminated

The 7234 contains protection circuitry that disables the amplifier if an output stage is behaving abnormally. This usually indicates an output transistor has shorted.

To clear the Fault condition, follow these steps:

1. Turn off the signal source.
2. Turn off the AC mains.
3. Turn AC mains power back on. If the Fault LED doesn't illuminate again, turn the signal source on.
4. If the Fault LED is still illuminated and the Fault condition doesn't clear, return the amplifier for

Factory Service. See the Factory Service information at the end of this section.

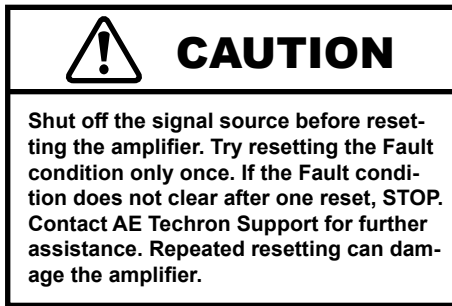

8.10 Factory Service

If the troubleshooting procedures are unsuccessful, the amplifier may need to be returned for Factory Service. All units under warranty will be serviced free of charge (customer is responsible for one-way shipping charges as well as any custom fees, duties, and/or taxes). Please review the Warranty at the beginning of this manual for more information.

All service units must be given Return Authorization by AE Techron, Inc. before being returned. Return Authorizations can be requested on our website or by contacting our Customer Service Department.

Please take extra care when packaging your amplifier for repair. It should be returned in its original packaging or a suitable alternative. Replacement packaging materials can be purchased for a nominal fee.

Please send all service units to the following address and be sure to include your Return Authorization Number on the box.

AE Techron, Inc.
Attn: Service Department / RMA#
2507 Warren Street
Elkhart, IN 46516

Appendix A: Alternate Interconnect Ports Application Wiring

Remote Status and Control using the Interconnect Ports

For Units with Serial Numbers Ending in "A"

CAUTION

These Application instructions for the Interconnect Ports apply only to units with a **serial number ending in "A."** Units with a **serial number ending in "B"** were built using a different configuration for these 9-pin D-Sub connectors. For proper wiring for units with a serial number ending in "B," please refer to the topic titled "Remote Status and Control using the Interconnect Ports" in the *Applications* section of this manual.

The information provided here will instruct you in the wiring of control and status applications including:

- Remote Enable/Standby
- Temperature monitor
- Current monitor

Figure A.1 maps the pins used for these applications. NOTE: Both 9-pin D-Sub connectors have the same pin-outs and either port can be used for remote applications.

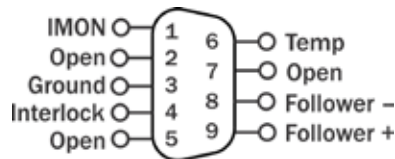

Figure A.1 – Remote Status and Control Pin-outs on 9-pin D-Sub Connectors

Remote Enable/Standby

Using one of the 9-pin D-Sub connectors located on the back panel of the amplifier, you can remotely Enable the amplifier and/or place the unit in Standby mode. See **Figure A.2**.

Purpose: Use a switch or optocoupler to remotely disable the amplifier and place it in Standby mode. Also, return the amplifier from Standby mode to the Run condition.

Method: Short PIN 4 (Interlock) of connector to Ground (PIN 3) using a dry contact switch or optocoupler. In multi-amp applications, a switch can be used for Parallel systems, but an optocoupler must be used for Series systems. Multiple amplifiers (sharing the same Ground power connections) can be simultaneously forced to Standby by daisy-chaining Interlock (PIN 4) across amps.

When Interlock (PIN 4) is shorted to Ground (PIN 3), amplifier is placed in Standby mode. When switch is open, amplifier is released to the Run condition.

Signal Type: DC

Level when Asserted: 0 to 8 V

Level when Deasserted: 10 to 15 V

IMPORTANT: The amplifier must be configured for Ready mode at startup (factory default) or the Run button must be pressed at the amplifier front panel at startup. The Remote Enable/Standby circuit will not function if the Startup to Standby Latch has been activated on the amplifier.

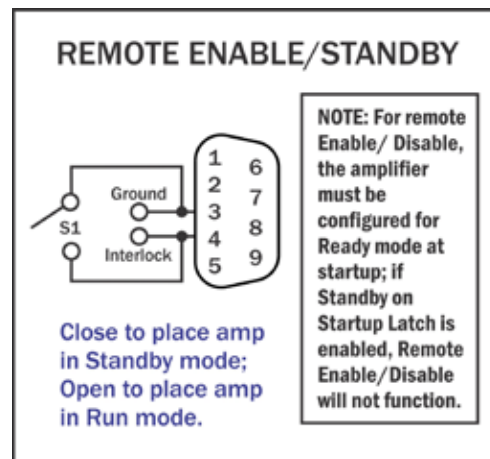

Figure A.2 – Remote Enable/Standby

Remote Monitoring of Temperature

Using one of the 9-pin D-Sub connectors located on the back panel of the amplifier, you can remotely monitor the temperature at the heat-sinks of the amplifier.

Purpose: Use a voltage meter to monitor temperature at the heat-sinks.

Method: Connect a voltage meter to monitor the temperature at the heatsinks of the amplifier. Connect across Temp (PIN 6) and Ground (PIN 3). See **Figure A.3**.

Signal Type: AC

Level: (VDC X 100) - 273 = degrees Celsius

IMPORTANT: This circuit has a 1K build-out resistor. Make sure the monitor function has sufficient impedance to avoid accidentally influencing status.

Most digital multimeters have an input impedance of 1 megohm and would work well for this application.

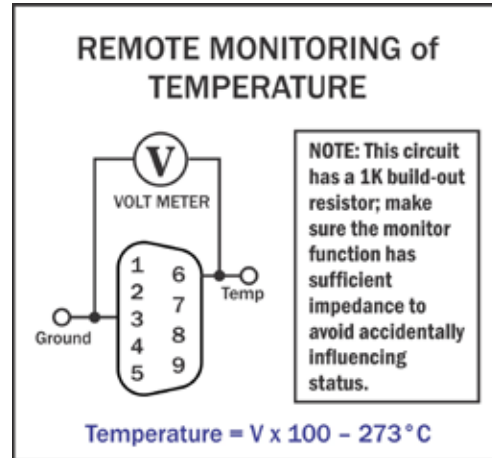

Figure A.3 – Remote Temperature Monitor

Remote Monitoring of Current Output

Using one of the 9-pin D-Sub connectors located on the back panel of the amplifier, you can remotely monitor current output.

Purpose: Use a voltage meter to monitor output current.

Method: Connect a voltage meter to monitor the output current being produced by the amplifier. Connect across I MON (PIN 1) and Ground (PIN 3). See **Figure A.4**.

Signal Type: AC

Level: 5A/V

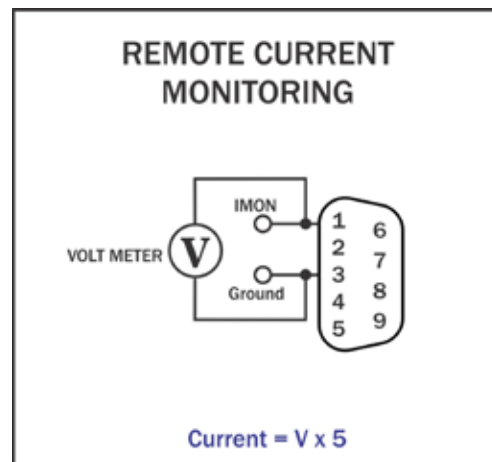

Figure A.4 – Remote Current Monitor