

AETECHRON



7224RLY

Operator's Manual Supplement

For Variable, Very-Low-Impedance Loads in Controlled-Current Mode

NOTE

This Supplement only provides information specific to the 7224RLY model and is intended to be used together with the AE Techron 7224 Operator's Manual. Please refer to the Operator's Manual for general information about safety, installation, operation and trouble-shooting.

1 Introduction

The 7224RLY amplifier is a special model of the AE Techron 7224 amplifier that has been modified to make it suitable for driving a Protection Relay or other variable very-low impedance loads in controlled-current mode.

Capable of outputting a 40 mSec pulse with up to 52 amperes peak current, the 7224RLY is powerful enough to put protection relays, fuses and other critical components through a full range of tests. The low noise floor, low distortion and minimal phase error of the 7224RLY make it the ideal amplifier for power grid modeling.

1.1 Features

- Factory preset for controlled-current operation.
- Multi-pole compensation optimized for resistive loads below 2 ohms.

1.2 About AE Techron

- AE Techron focuses on the development of power conversion and amplifier solutions for difficult environments. In addition to a line of standard power supplies and power amplifier products, AE Techron provides the design and manufacture of custom, high-quality, low-volume electronic products for research, military and industrial applications.

2 Factory Configuration (Factory Default Settings)

Your 7224RLY amplifier differs from a standard AE Techron 7224 amplifier in the following ways:

1. The 7224RLY ships with **Controlled Current** set as the default mode of operation. Note that the amplifier operation mode can be changed to Controlled Voltage mode by adjusting the setting for DIP switch #1, located on the amplifier back panel (see the “DIP Switch Functions and Default Settings” section in this supplement).
2. The 7224RLY ships with a multi-pole compensation enabled for the compensation setting for Controlled Current mode. The compensation is optimized for resistive loads below 2 ohms but is stable with higher impedances. Note that the amplifier Compensation Setting can be changed to the standard 7224 setting by adjusting the setting DIP switch #2, located on the amplifier back panel (see the “DIP Switch Functions and Default Settings” section in this supplement).

CAUTION

The 7224RLY is designed for pulsed operation and should not be run at high power levels for long periods of time (greater than 5 minutes). Damage to components in the output of the amplifier can result from extended high-power usage (1,000 watts or above).

3 Setup

Please refer to the AE Techron 7224 Operator's Manual for standard 7224RLY Unpacking and Installation instructions.

CAUTION

ELECTRIC SHOCK HAZARD.
Output potentials can be lethal. Make connections only with AC Power OFF and input signals removed.

4 Connections

4.1 Connecting the Load

Before connecting the amplifier, make sure the AC power cord is unplugged.

Connection to the outputs of the amplifier is with #8 screws. Wires terminated with #8 spade or ring terminals, tinned wires up to 10GA in size, or bus bars with 0.18 in. (4.6 mm) holes are recommended when connecting to the output terminals.

Connect the load across the COMMON (negative/ground) and OUTPUT (positive) terminals located on the 3-position terminal strip on the amplifier back panel. The CHASSIS GROUND terminal also located on the 3-position terminal strip can be connected to an external ground point such as the rack chassis. See **Figure 4.2**.

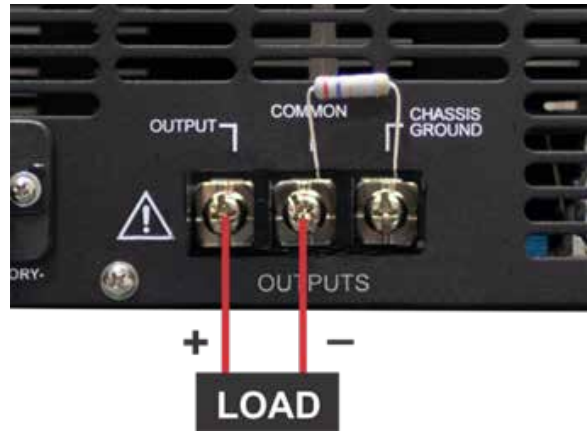

Figure 4.2 – Connecting the Load

Always use the appropriate wire size and insulation for the maximum current and voltage expected at the output. Never connect the output of the amplifier to any other model amplifier, power supply, signal source, or other inappropriate load; fire can result.

NOTE: The 7224RLY amplifier comes with a factory-installed 2.7-ohm, 2W, 5%, metal-oxide resistor connecting the terminals marked COM and

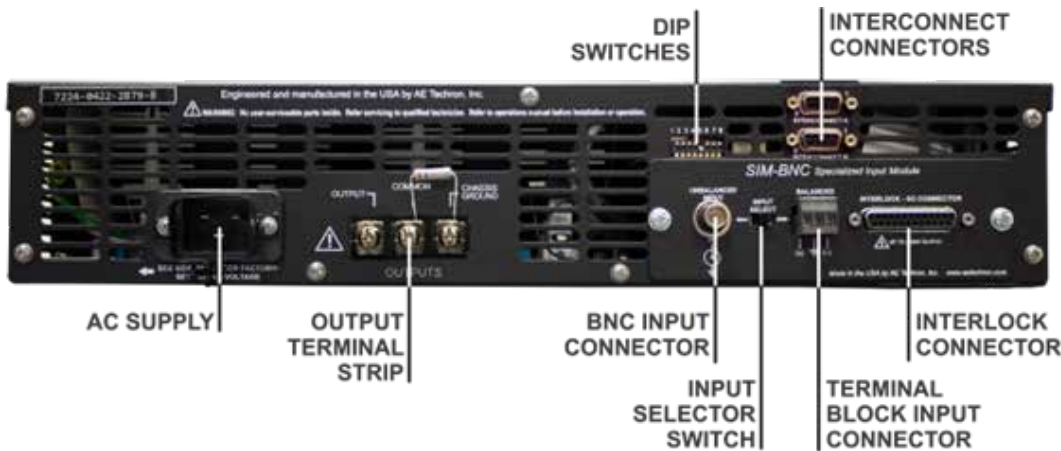

Figure 4.1 – 7224RLY Back Panel Connectors



CHASSIS GROUND. This resistor should NOT be removed. **WARNING: Removing this resistor can cause dangerous output and/ or damage to the load.**

4.2 Connecting the Input Signal

The signal is connected to the amplifier through a “SIM (Specialized Input Module) Card” located on the amplifier back panel. The standard SIM card includes both an Unbalanced Input BNC jack and a Balanced Input “WECO” terminal block connector, an Input Select switch, and an Interlock – I/O Connector. (See the “Applications” section in the **7224 Operator’s Manual** for information on using the Interlock – I/O Connector).

Position the Input Select switch to the left to select the Unbalanced Input connector and to the right to select the Balanced Input connector. See **Figure 4.3**. Note that when the Input Select switch is in the right position, both Unbalanced and Balanced Input connectors are enabled.

IMPORTANT: The Input Select switch also functions as a Ground Lift switch for the Unbalanced Input connector. If circulating currents/ ground loops/60-Hz Hum occur when using the Unbal-

anced Input, move the Input Select switch to the right to lift the ground on the connector.

Connect your input signal to the amplifier’s unbalanced or balanced input connector as shown in **Figure 4.4**. Use cables that are high quality and shielded to minimize noise and to guard against possible feedback.

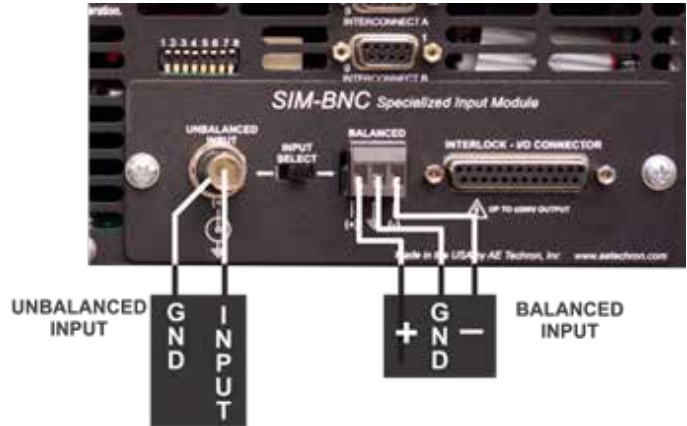

Figure 4.4 – Wiring for Balanced or Unbalanced Input Connector

4.3 Connecting the AC Supply

The power cord connects to a standard 20 amp 3-pin IEC-type male connector on the amplifier back panel. Make sure the Breaker/Switch on the front panel is switched to the OFF (O) position. Make sure the power cord is inserted and seated fully into the IEC connector by moving it slightly back and forth and up and down while pushing in. The power cord is relatively stiff and should be routed so that there is no excessive force pulling to the sides or up or down that would stress the pins or internal connections. Tighten the cord strain relief screw to lock the power cord in place.

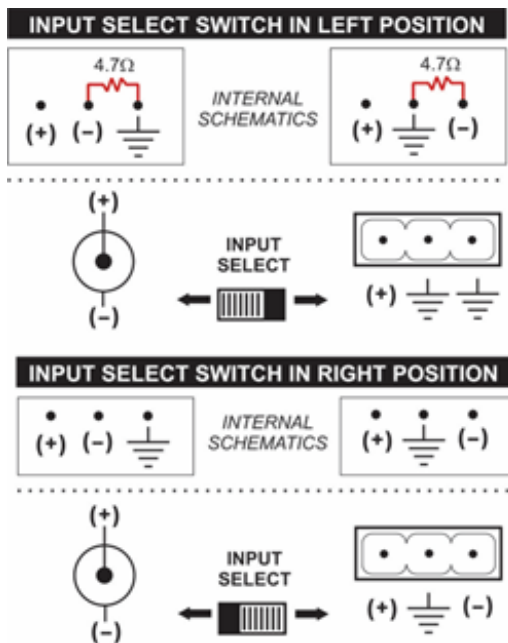

Figure 4.3 – Input Select Switch Settings

5 Startup Sequence

IMPORTANT: This 7224RLY amplifier has been configured for Controlled-Current operation. **DO NOT** operate the amplifier without first making sure a load is properly attached to the amplifier.

1. Turn down the level of your signal source.
2. Turn down the gain control of the amplifier.
3. Turn the ON/OFF/BREAKER switch located on the amplifier front panel to the “ON” (I) position to turn the amplifier ON.
4. Wait for the yellow READY and green RUN LEDs to illuminate.
5. Adjust the level of your input signal source to achieve the desired output level.
6. Turn up the Gain control on the amplifier until the desired voltage or power level is achieved.
7. Adjust the input signal level to achieve the desired output level.

WARNING: If amplifier has been unused/inactive for 2 years or more, please startup connected to a low-voltage DC power supply. Start at 10% of the rated voltage and gradually increase to avoid damaging internal components.

6 Operation and Troubleshooting

Please refer to the AE Techron *7224 Operator's Manual* for standard 7224RLY Operation and Troubleshooting instructions.

7 DIP Switch Functions and Default Settings

These configuration settings and locations are valid for 7224RLY amplifiers with internal or external DIP switches (versions B, C, and D as described in the 7224 Operator's Manual).

Your 7224RLY amplifier has configuration options that enable and can enhance the amplifier's operation and performance for power grid simulation and relay testing. Please refer to the chart in **Figure 7.1** for 7224RLY factory default DIP switch settings and a basic description of the function of each DIP switch. For more detailed information about each DIP switch setting and its uses, refer to the “Advanced Configuration” section in the AE Techron *7224 Operator's Manual*.

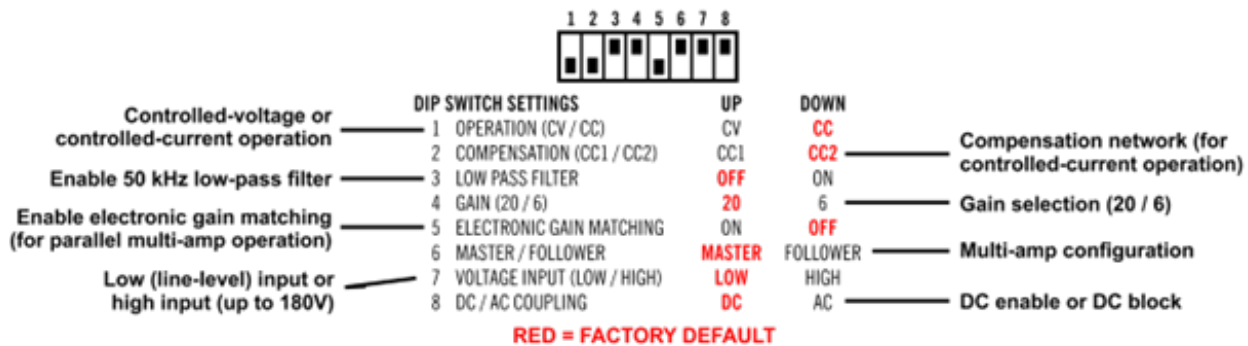

Figure 7.1 – Chart of DIP Switch Functions and Default Settings for 7224RLY

Refer to **Figure 7.2** for control locations on the amplifier main board. **Figure 7.3** details the factory default settings for all 7224RLY DIP switches.

The illustration on the following page, showing the main board with captioned allouts, provides a visual location of main board functions (see **Figure 8.1**).

8 Main Board Functions and Jumper Settings

Please refer to the following for details of main board jumper functions and the factory default settings.

NAME	DESCRIPTION	FACTORY DEFAULT SETTING
STANDBY ON OVERLOAD	The MODEL 7224RLY is factory-configured with the OVERLOAD LATCH disabled. When a jumper is in place across the two pins labeled JP406, any activation of the IOC (Input Output Comparator), distortion alert circuit, (activation occurs at 0.5% error), will cause the amplifier to move to a Standby condition. Once in Standby, the amplifier must be reset by pressing the front-panel RESET button, or by presenting a remote RESET signal on the I/O Connector, to move the amplifier back to a RUN (Operational) condition.	DISABLED (jumper absent)
CUSTOM COMPENSATION	When the 7224RLY amplifier is used in Controlled-Current mode, the current control loop is tuned with an RC network. The factory default network used for the 7224RLY (CC2) is a multi-pole compensation optimized for resistive loads below 2 ohms.	Populated
STARTUP IN STANDBY	The 7224RLY is factory-configured to automatically move into RUN mode on Start Up. In RUN mode, the amplifier will amplify an input signal. To place the amplifier in STANDBY mode on Start Up, move the jumper to the two UPPER pins. When in STANDBY mode on Start Up, the amplifier will be placed in Standby mode until the front-panel ENABLE button is pressed or a remote ENABLE signal is received on the I/O Connector. To return the amplifier to RUN mode on Start Up, move the jumper to the two LOWER pins.	ENABLE (LOWER)
FIXED GAIN	The 7224RLY amplifier ships with an enabled Gain Control knob, which is located on the amplifier front panel. To disable the Variable Gain control and set for a Fixed Gain, locate the Gain Control Bypass jumper, remove the gain control wire, and place a shunt across the two pins at that location.	Variable Gain ENABLED

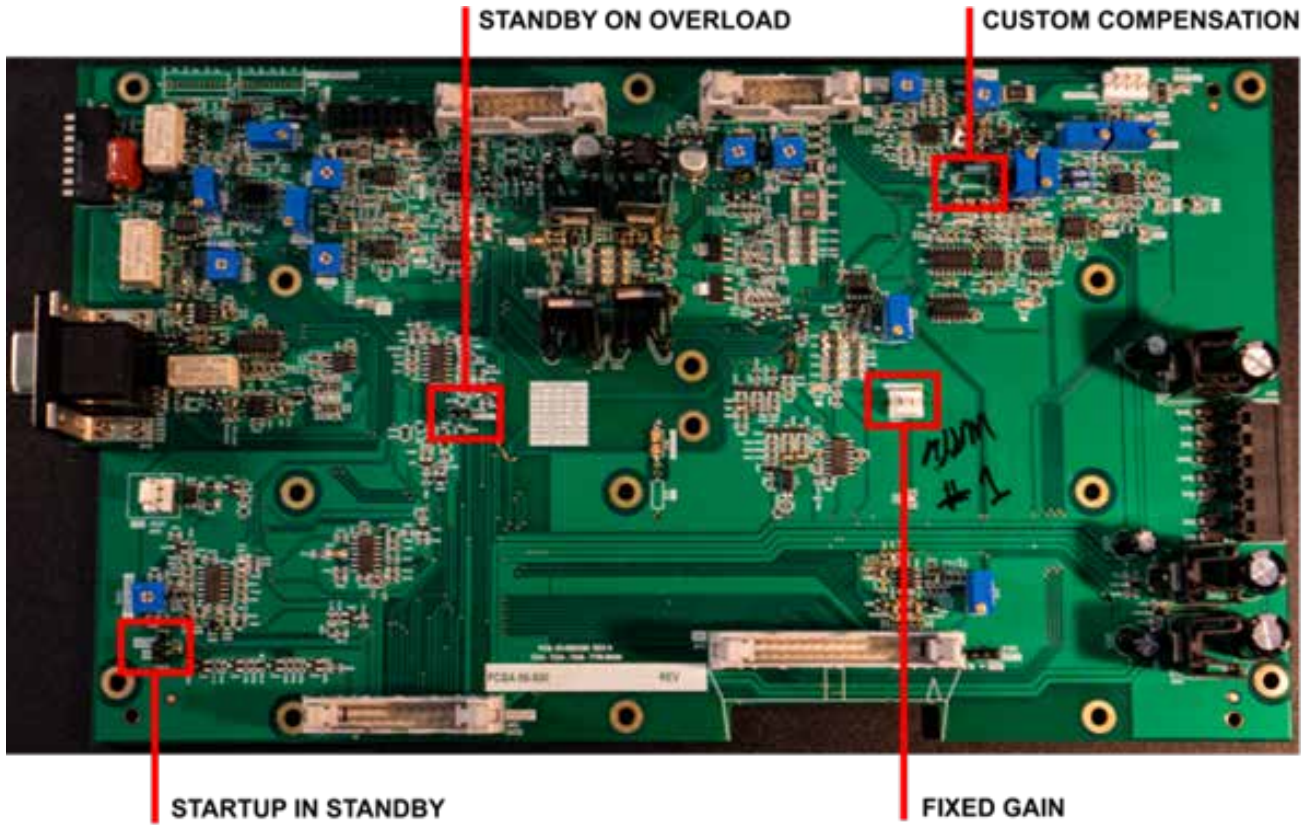

Figure 8.1 – Main Board Component Locations

9 Accuracy

Amplitude vs. Frequency			
1V input, 20A output, amplifier transconductance set to 20:			
Load	Input Signal	Transconductance	
		1 kHz	100 Hz
2 ohms	Sine	19.9	20
1 ohm	Sine	20	20
0.5 ohm	Sine	20	20
Short (unimpeded wire)	Sine	20	20

10 Specifications

Please refer to the **7224RLY** datasheet for information about the product’s performance, features and physical characteristics. The product datasheet is available for download from the AE Techron website at www.aetechron.com.

The following specifications apply to a 7224RLY amplifier using the default factory settings.

7224RLY Pulse/Burst Specifications:

Maximum Current: 35Arms, 50Apeak, 0.5 ohms			
Maximum Voltage: 158Vpeak			
Total Load	Duration	Waveform	Output Power
1.0 ohm	5 minutes	60 Hz Sine	28Arms/40Apeak
		DC	20Apeak
	20 second	60 Hz Sine	30Arms/43Apeak
		DC	20Apeak
	0.2 second	60 Hz Sine	33Arms/47Apeak
		DC	30Apeak

Maximum Output Current:

50 amps peak

Maximum Output Voltage:

158 volts peak / 72 volts peak, field selectable

Maximum Output Power:

Dependent on load and frequency

Load Constraint for Maximum Output:

0.5 ohms + 200 μ H

* All loads from 8-ohm to short are stable with 2 mH in series.

Output Offset Current:

Less than 10.0 milliamperes DC peak

Input:

Standard Transconductance: 20 \pm 0.2% from short to 1-ohm loads

Common Mode Rejection Ratio: -58 dB minimum, 40-600Hz

Unit to Unit Phase Error:

Less than 0.1 at 60Hz

Residual Noise:

Less than 2.5 milliamperes peak (40Hz - 600Hz)

Input to Output Phase Delay:

-0.2

Out Accuracy:

Less than \pm 1%

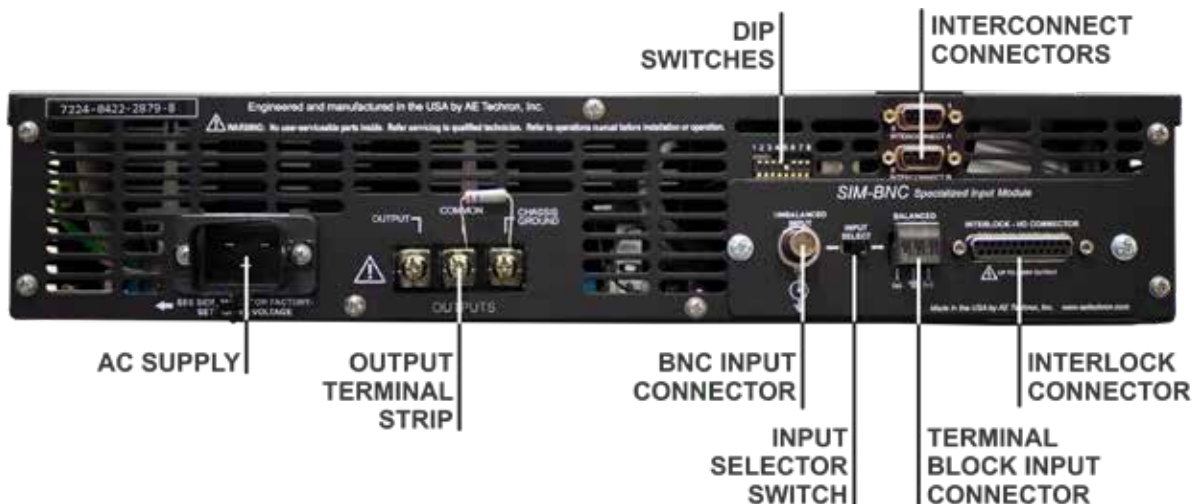

Figure 10.1 – 7224RLY Back Panel (Version D configuration shown)