

AETECHRON



7548/7794/7796/7796HC

Operator's Manual

Single-Channel Industrial Amplifiers for Demanding, High-Power Systems

APPLIES TO UNITS WITH MAINBOARD PART NUMBER 65-8005300-H

574.295.9495 | www.aetechron.com
2507 Warren Street, Elkhart, IN 46516

Three-Year, No-Fault Warranty

SUMMARY OF WARRANTY

AE TECHRON INC., of Elkhart, Indiana (Warrantor) warrants to you, the ORIGINAL COMMERCIAL PURCHASER and ANY SUBSEQUENT OWNER of each NEW **AE TECHRON INC. product, for a period of three (3) years from the date of purchase, by the original purchaser (warranty period) that the product is free of defects in materials and workmanship and will meet or exceed all advertised specifications for such a product. We further warrant the new AE Techron product regardless of the reason for failure, except as excluded in the Warranty.**

ITEMS EXCLUDED FROM WARRANTY

This AE Techron Warranty is in effect only for failure of a new AE Techron product which occurred within the Warranty Period. It does not cover any product which has been damaged because of any intentional misuse, or loss which is covered under any of your insurance contracts. This warranty does not extend to any product on which the serial number has been defaced, altered, or removed. It does not cover damage to loads or any other products or accessories resulting from **AE TECHRON INC.** product failure. It does not cover defects or damage caused by the use of unauthorized modifications, accessories, parts, or service.

WHAT WE WILL DO

We will remedy any defect, regardless of the reason for failure (except as excluded), by repair or replacement, at our sole discretion. Warranty work can only be performed at our authorized service centers or at our factory.

Expenses in remedying the defect will be borne by **AE TECHRON INC.**, including one-way surface freight shipping costs within the United States. (Purchaser must bear the expense of shipping the product between any foreign country and the port of entry in the United States and all taxes, duties, and other customs fees for such foreign shipments.)

HOW TO OBTAIN WARRANTY SERVICE

When you notify us or one of our authorized service centers of your need for warranty service, you will receive an authorization to return the product for service. All components must be shipped in a factory pack or equivalent which, if needed, may be obtained

from us for a nominal charge. We will take corrective actions and return the product to you within three weeks of the date of receipt of the defective product, or will make available to you a product of equal or better performance on temporary loan until your product can be repaired or replaced and returned to you. If the repairs made by us are not satisfactory, notify us immediately.

DISCLAIMER OF CONSEQUENTIAL AND INCIDENTAL DAMAGES

You are not entitled to recover from us any consequential or incidental damages resulting from any defect in our product. This includes any damage to another product or products resulting from such a defect.

WARRANTY ALTERATIONS

No person has the authority to enlarge, amend, or modify this warranty. The warranty is not extended by the length of time for which you are deprived of the use of this product. Repairs and replacement parts provided under the terms of this warranty shall carry only the unexpired portion of this warranty.

DESIGN CHANGES

We reserve the right to change the design of any product from time to time without notice and with no obligation to make corresponding changes in products previously manufactured.

LEGAL REMEDIES OF PURCHASER

There is no warranty that extends beyond the terms hereof. This written warranty is given in lieu of any oral or implied warranties not contained herein. We disclaim all implied warranties, including, without limitation, any warranties of merchantability or fitness for a particular purpose. No action to enforce this Warranty shall be commenced later than ninety (90) days after expiration of the warranty period. This statement of warranty supersedes any others contained in this manual for AE Techron products.

AE TECHRON INC.

Customer Service Department

2507 Warren St. Elkhart, IN, 46516, U.S.A.

(574) 295-9495

www.aetechron.com

DECLARATION OF CONFORMITY

Technical Construction File Route

Issued By: AE Techron, Inc.
2507 Warren Street
Elkhart, IN 46516

For Compliance Questions Only: Larry Shank
574-295-9495
lshank@aetechron.com

This Declaration of Conformity is issued under the sole responsibility of AE Techron, Inc., and belongs to the following product:

Equipment Type: Industrial Power Amplifiers

Model Name: 7548

EMC Standards:

- EN 61326-1: 2013 – Electrical equipment for measurement, control and laboratory use
 - EMC Requirements
- EN 55011: 2009 + A1: 2010 – Industrial, scientific and medical (ISM) radio-frequency equipment:
 - Radio disturbance characteristics
 - Limits and methods of measurement
- EN 61000-4-2: 2009 – Electromagnetic compatibility (EMC) Part 4: Testing and measurement techniques:
 - Electrostatic discharge immunity test
- EN 61000-4-3: 2006 + A2: 2010 – Electromagnetic compatibility (EMC) Part 4: Testing and measurement techniques:
 - Radiated radio-frequency electromagnetic field immunity test
- EN 61000-4-4: 2004 + A1: 2010 – Electromagnetic compatibility (EMC) Part 4: Testing and measurement techniques:
 - Electrical fast transient/burst immunity test
- EN 61000-4-5: 2006 – Electromagnetic compatibility (EMC) Part 4: Testing and measurement techniques:
 - Surge immunity test
- EN 61000-4-6: 2009 – Electromagnetic compatibility (EMC) Part 4: Testing and measurement techniques:
 - Immunity to conducted disturbances induced by radio frequency field
- EN 61000-4-8: 2010 – Electromagnetic compatibility (EMC) Part 4: Testing and measurement techniques:
 - Power frequency magnetic field immunity test

Safety Standard:

BSEN61010-1:2010 (inc Corr. May 2011) – Safety requirements for electrical equipment for measurement, control, and laboratory use

I certify that the product identified above conforms to the requirements of the EMC Council Directive 2004/108/EC (until 19th April, 2016) and Directive 2014/30/EU (from 20th April, 2016), and the Low Voltage Directive 2006/95/EC (until 19th April, 2016) and Directive 2014/35/EU (from 20th April, 2016).

Signed:

Larry Shank
President



Place of Issue: Elkhart, IN, USA
Date of Issue: March 18, 2016

CE Affixing Date: March 4, 2011

DECLARATION OF CONFORMITY

Technical Construction File Route

Issued By: AE Techron, Inc.
2507 Warren Street
Elkhart, IN 46516

For Compliance Questions Only: Larry Shank
574-295-9495
lshank@aetechron.com

This Declaration of Conformity is issued under the sole responsibility of AE Techron, Inc., and belongs to the following product:

Equipment Type: Industrial Power Amplifiers

Model Name: 7794

EMC Standards:

- EN 61326-1: 2013** – Electrical equipment for measurement, control and laboratory use
 - EMC Requirements
- EN 55011: 2009 + A1: 2010** – Industrial, scientific and medical (ISM) radio-frequency equipment:
 - Radio disturbance characteristics
 - Limits and methods of measurement
- EN 61000-4-2: 2009** – Electromagnetic compatibility (EMC) Part 4: Testing and measurement techniques:
 - Electrostatic discharge immunity test
- EN 61000-4-3: 2006 + A2: 2010** – Electromagnetic compatibility (EMC) Part 4: Testing and measurement techniques:
 - Radiated radio-frequency electromagnetic field immunity test
- EN 61000-4-4: 2004 + A1: 2010** – Electromagnetic compatibility (EMC) Part 4: Testing and measurement techniques:
 - Electrical fast transient/burst immunity test
- EN 61000-4-5: 2006** – Electromagnetic compatibility (EMC) Part 4: Testing and measurement techniques:
 - Surge immunity test
- EN 61000-4-6: 2009** – Electromagnetic compatibility (EMC) Part 4: Testing and measurement techniques:
 - Immunity to conducted disturbances induced by radio frequency field
- EN 61000-4-8: 2010** – Electromagnetic compatibility (EMC) Part 4: Testing and measurement techniques:
 - Power frequency magnetic field immunity test

Safety Standard:

BSEN61010-1:2010 (inc Corr. May 2011) – Safety requirements for electrical equipment for measurement, control, and laboratory use

I certify that the product identified above conforms to the requirements of the EMC Council Directive 2004/108/EC (until 19th April, 2016) and Directive 2014/30/EU (from 20th April, 2016), and the Low Voltage Directive 2006/95/EC (until 19th April, 2016) and Directive 2014/35/EU (from 20th April, 2016).

Signed:

Larry Shank
President



Place of Issue: Elkhart, IN, USA
Date of Issue: April 14, 2016

CE Affixing Date: April 14, 2016

DECLARATION OF CONFORMITY

Technical Construction File Route

Issued By: AE Techron, Inc.
2507 Warren Street
Elkhart, IN 46516

For Compliance Questions Only: Larry Shank
574-295-9495
lshank@aetechron.com

This Declaration of Conformity is issued under the sole responsibility of AE Techron, Inc., and belongs to the following product:

Equipment Type: Industrial Power Amplifiers

Model Name: 7796

EMC Standards:

- EN 61326-1: 2013 – Electrical equipment for measurement, control and laboratory use
— EMC Requirements
- EN 55011: 2009 + A1: 2010 – Industrial, scientific and medical (ISM) radio-frequency equipment:
— Radio disturbance characteristics
— Limits and methods of measurement
- EN 61000-4-2: 2009 – Electromagnetic compatibility (EMC) Part 4: Testing and measurement techniques:
Electrostatic discharge immunity test
- EN 61000-4-3: 2006 + A2: 2010 – Electromagnetic compatibility (EMC) Part 4: Testing and measurement techniques:
Radiated radio-frequency electromagnetic field immunity test
- EN 61000-4-4: 2004 + A1: 2010 – Electromagnetic compatibility (EMC) Part 4: Testing and measurement techniques:
Electrical fast transient/burst immunity test
- EN 61000-4-5: 2006 – Electromagnetic compatibility (EMC) Part 4: Testing and measurement techniques:
Surge immunity test
- EN 61000-4-6: 2009 – Electromagnetic compatibility (EMC) Part 4: Testing and measurement techniques:
Immunity to conducted disturbances induced by radio frequency field
- EN 61000-4-8: 2010 – Electromagnetic compatibility (EMC) Part 4: Testing and measurement techniques:
Power frequency magnetic field immunity test

Safety Standard:

BSEN61010-1:2010 (inc Corr. May 2011) – Safety requirements for electrical equipment for measurement, control, and laboratory use

I certify that the product identified above conforms to the requirements of the EMC Council Directive 2004/108/EC (until 19th April, 2016) and Directive 2014/30/EU (from 20th April, 2016), and the Low Voltage Directive 2006/95/EC (until 19th April, 2016) and Directive 2014/35/EU (from 20th April, 2016).

Signed:

Larry Shank
President



Place of Issue: Elkhart, IN, USA
Date of Issue: March 18, 2016

CE Affixing Date: March 4, 2011

Contents

1	Introduction	7
1.1	Features	7
2	Amplifier Unpacking and Installation	8
2.1	Safety First	8
2.2	Unpacking	8
2.3	Installation	8
2.4	Connecting the Load	9
2.5	Connecting the Input Signal	10
2.6	Connecting the AC Supply	11
2.7	Start-up Procedure	11
3	Amplifier Operation	12
3.1	Front-Panel Controls & Display	12
3.2	Front-Panel Indicators	13
3.3	Back-Panel Controls and Connectors	17
4	Advanced Configuration	18
4.1	Factory Defaults	18
4.2	Accessing the Main Board	18
4.3	Configuration Settings Controlled by DIP Switches	18
4.4	Configuration Settings Controlled by Jumpers	21
4.5	Adjusting the Bi-Level Power Supply Switch	21
5	Applications	23
5.1	Remote Status and Control using the SIM Interlock I/O Connector	23
5.2	Controlled Current Operation	28
5.3	Multi-amplifier Systems	33
6	Maintenance	50
6.1	Clean Amplifier Filter and Grills	50
7	Troubleshooting	51
7.1	Introduction & Precautions	51
7.2	Visual Inspection	51
7.3	No Signal	51
7.4	No LEDs Illuminated or No Fans	51
7.5	OverVoltage Warning Message	52
7.6	Standby LED Remains Illuminated	52
7.7	Amplifier Overheats (Over Temp Fault Condition)	52
7.8	Fault LED is Illuminated	53
7.9	Factory Service	53

List of Figures

Figure 1.1 – 7548 Front Panel.....	7
Figure 2.1 – Connecting the Load	9
Figure 2.2 – Close-up of the Output Terminal Resistor	9
Figure 2.3 – Close-up of SIM card.....	10
Figure 2.4 – Wiring for Unbalanced or Balanced Input Connector.....	10
Figure 2.5 – 208V 3-Phase AC Mains Wiring.....	11
Figure 2.6 – 380/400/415V 3-Phase AC Mains Wiring.....	11
Figure 3.1 – Front Panel Controls and Display.....	12
Figure 3.2 – Front Panel Indicators	13
Figure 3.3 – Main Status Indicators for Stand-Alone Amplifiers	13
Figure 3.4 – Fault Status Indicators for Stand-Alone Amplifiers	14
Figure 3.5 – Main Status Indicators for Multi-Amplifier Systems.....	15
Figure 3.6 – Fault Status Indicators for Multi-Amplifier Systems.....	16
Figure 3.7 – Back Panel Controls and Connectors	17
Figure 4.1 – Main Board Configuration Locations	19
Figure 4.2 – DIP Switch Settings and Descriptions	19
Figure 4.3 – Enable/Stop on Power-up Configuration.....	21
Figure 4.4 – Configure for Standby (Fault Mode) on Overload	21
Figure 4.5 – Bi-Level Power Switch Location.....	22
Figure 5.1 – Remote Status and Control Pinouts on 25-pin D-Sub Connector (SIM card)	23
Figure 5.2 – Remote Run/Standby Monitor	23
Figure 5.3 – Remote Status and Reset Schematic	24
Figure 5.4 – Remote Enable/Standby	25
Figure 5.5 – Remote Current Monitoring.....	26
Figure 5.6 – Remote Current Monitoring, Alternate Method.....	26
Figure 5.7 – Remote Monitoring of Temperature.....	27
Figure 5.8 – Blanking Activation	27
Figure 5.9 – Input to Output Comparison, Controlled-Voltage Operation.....	28
Figure 5.10 – Input to Output Comparison, Controlled-Current Operation.....	28
Figure 5.11 – Factory-installed Default RC Network	29
Figure 5.12 – Custom Compensation Component Locations.....	31
Figure 5.13 – Compensation Effects on Waveform.....	32
Figure 5.14 – Square Wave Showing a Decrease in R is Required.....	32
Figure 5.15 – Square Wave Showing an Increase in R is Required	32
Figure 5.16 – Square Wave Showing an Increase in C is Required	32
Figure 5.17 – Typical Output Levels for 7548, 7794, 7796 & 7796HC Multiamp Systems.....	33
Figure 5.18 – DIP Switch Settings for Push/Pull Configuration.....	34
Figure 5.19 – System Configuration for Push-Pull Multi-amp Operation.....	35
Figure 5.20 – DIP Switch Settings for Parallel Configuration	37
Figure 5.22 – Locations for Balancing Controls on the Main Board	38
Figure 5.21 – Terminating the Amplifier Input.....	38
Figure 5.23– Parallel Balanced Input Wiring Using Removable Barrier Block Connectors (Four in Parallel Shown).....	39
Figure 5.24– Parallel Unbalanced Input Wiring Using BNC Wiring and Connectors (Three in Parallel Shown).....	39
Figure 5.25 – System Configuration for Parallel Multi-amp Operation	41
Figure 5.26 – DIP Switch Settings for Series Configuration.....	42
Figure 5.27 – SIM-BNC-OPTOC jumper locations	42
Figure 5.28 – SIM-BNC-OPTOC input connectors' internal wiring.....	43
Figure 5.29 – Output Terminal Resistor.....	43
Figure 5.30 – System Configuration for Two in Series Multi-amp Operation.....	44
Figure 5.31 – System Configuration for Three in Series Multi-amp Operation.....	45
Figure 7.1 – Amplifier cover removed for inspection	51
Figure 7.2 – Fuse F1 Location.....	52
Figure 7.3 – Interlock I/O Connector	52



Figure 1.1 – 7548 Front Panel

1 Introduction

Congratulations on your purchase of the 7548, 7794, 7796 or 7796HC AE Techron power amplifier—a single -channel industrial amplifier designed for use in the most demanding high-power systems. The 7548, 7794, 7796 and 7796HC amplifiers are built and tested to the most stringent quality standards for long life and outstanding performance. The AE Techron brand is known throughout the world for its robust precision amplifiers as well as its product service and support.

1.1 Features

The 7548/7794/7796/7796HC, when operated in Controlled Voltage mode, provides precision amplification at frequencies from DC to 30 kHz, and DC to 100 kHz+ at reduced power, with low harmonic and intermodulation distortion and low noise. The 7548/7794/7796/7796HC operates on 208-volt (optional 400-volt, except 7796HC amplifier) 3-phase AC mains. Other features include:

- DC-enabled, four-quadrant, linear amplifier.
- Standard SIM (Specialized Input Module) features unbalanced BNC, balanced Phoenix-type 3-pin input, and 25-pin Interlock – I/O connectors. Optional SIM modules are available or can be created to provide additional features for unique applications.
- Built-in protection circuitry safely provides for sustained, full-power output. Full protection includes:
 - Over-Voltage
 - Over-Temperature
 - Temperature monitor of heat-sinks, transformers and output transistors
 - Immediate protection and fast recovery in the event of overheating.
- Generous, front-to-back cooling allows tight rack mounting without the need for air spaces and permits longer run times at higher duty cycles.
- Switching, bi-level power supply adapts to meet demands for high voltage or high current.
- Convenient, multi-function front-panel LCD display provides peak and RMS values for voltage and current measured directly from the output of the amplifier. Status indicators, and sealed navigation and input buttons, are also conveniently located on the front panel.

2 Amplifier Unpacking and Installation

The 7548, 7794, 7796 and 7796HC amplifiers are precision instruments that can be dangerous if not handled properly. Lethal voltages are present in both the AC input supply and the output of these amplifiers. For this reason, safety should be your primary concern when you setup and operate this amplifier.

2.1 Safety First

Throughout this manual special emphasis is placed on good safety practices. The following graphics are used to highlight certain topics that require extra precaution.

	DANGER
<p>DANGER represents the most severe hazard alert. Extreme bodily harm or death will occur if these guidelines are not followed. Note the explanation of the hazard and instruction for avoiding it.</p>	

	WARNING
<p>WARNING alerts you to hazards that could result in severe injury or death. Note the explanation of the hazard and the instructions for avoiding it.</p>	

	CAUTION
<p>CAUTION indicates hazards that could result in potential injury or equipment or property damage. Once again, note the explanation of the hazard and the instructions for avoiding it.</p>	

2.2 Unpacking

All amplifiers are tested and inspected for damage before leaving the factory. Carefully unpack and inspect the amplifier for damage. **Please note any damage for future reference and notify the shipping company immediately if damage is found.** Also, please save the shipping carton and materials as evidence of damage and/or for returning the amplifier for repair.

Along with any additional accessories purchased by the customer, all 7548/7794/7796/7796HC amplifiers ship with the following:

- Toolkit (contains one 1/8-inch Allen driver and three 2.7-ohm resistors)
- NEMA connector for Power Cord
- Operator's Manual USB drive and Quick Start sheet

	WARNING
<p>Never attempt to lift the amplifier without assistance. Crushing bodily injury can result if care is not taken during installation. Cabinets may overturn if not secured.</p>	

2.3 Installation

The 7548, 7794, 7796 and 7796HC amplifiers have rack "ears" on each side of the front panel for mounting to a standard EIA (Electronic Industries Association) rack. Use standard rack mounting hardware to mount the amplifier. Use nylon washers if you wish to protect the powder-coat finish on the front of the amplifier.

NOTE: The 7548 weighs approximately 103 pounds, and the 7794, 7796 and 7796HC weigh approximately 153 pounds. Be sure this weight is properly supported using all the screw locations.

When mounting the amplifier in a rack cabinet, the sidewalls of the rack must be at least 2 inches away from the chassis on both sides.

Allow for hot air discharge through the amplifier's rear grill. If your cabinet has a rear door, you must provide adequate airflow through the door. Provide a source of cool air for fan intakes. If the rack is crowded or rack ventilation is poor, use a vent tube to the outside of the rack. Cooling capacity required is 300 ft³/min. total per amp.

When operating the amplifier in a dusty environment, use commercial furnace filters, or equivalent, to prevent rapid clogging of the filters on the amplifier.

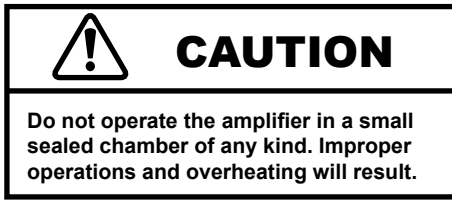

Optionally, the amplifier can be placed on a bench top; please keep in mind that the protective powder-coating can be scratched when placed on other equipment or on a bench top, especially when there is dirt present. To protect the finish, a set of rubber feet is included in the toolkit that can be installed on the bottom of the amplifier.

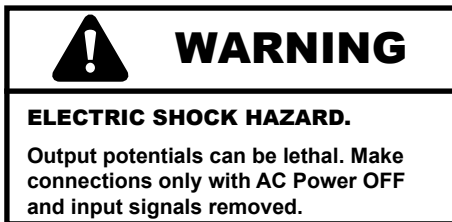

2.4 Connecting the Load

Before connecting the amplifier, make sure the AC power cord is unplugged.

This section describes output wiring to the load when using the default amplifier configuration: Single (or Master) amplifier operated in Controlled Voltage mode. The amplifier also can be field-adjusted for operation in Controlled Current mode or for operation as a Follower amplifier in a multi-amplifier system. These alternate configurations

may require special output wiring and/or additional components.

If your application requires Controlled Current and/or Follower operation, change the default settings on the main board before connecting the amplifier. (See the **Advanced Configuration** section for more information.)

Locate the four-position terminal barrier block labeled OUTPUTS on the amplifier back panel (see **Figure 2.1**).

NOTE: The 7548/7794/7796/7796HC amplifier comes with a factory-installed 2.7-ohm, 2W, 5%, metal-oxide resistor connecting the terminals marked “SAMPLED COMMON” and “CHASSIS GROUND” (see **Figure 2.2**). This resistor should NOT be removed. WARNING: Removing this resistor can cause dangerous output and/or damage to the load unless configuring multiple amplifiers in series. See the **AE Techron Multi-Amplifier Configuration Guide** for more information on these advanced configurations.

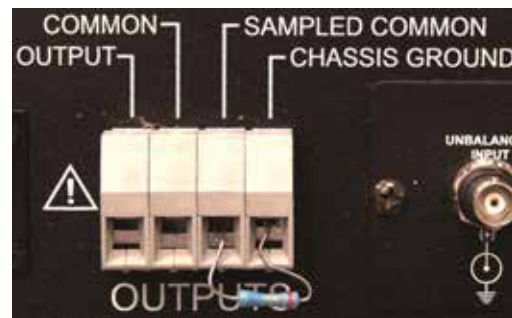

Figure 2.2 – Close-up of the Output Terminal Resistor

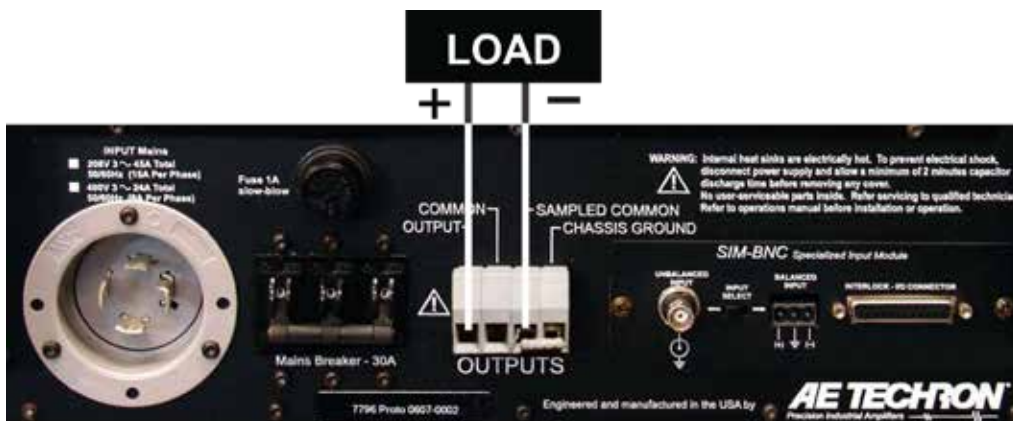

Figure 2.1 – Connecting the Load

2.4.1 Connecting the Outputs

The four-position terminal barrier block accepts up to #4 AWG wire. Always use the appropriate wire size and insulation for the maximum current and voltage expected at the output. Never connect the output of the amplifier to any other model amplifier, power supply, signal source, or other inappropriate load; fire can result.

1. Connect the negative terminal of the load to the SAMPLED COMMON terminal.
 NOTE: Alternately, the COMMON terminal may be used when operating in Controlled-Voltage mode; however, the integrated current monitor will not function if the COMMON terminal is used, since it depends on feedback from the Sampled Common terminal. For operation in Controlled-Current mode, the SAMPLED COMMON terminal must be used.
2. Connect the load's positive terminal to the amplifier's OUTPUT terminal.
3. The "CHASSIS GROUND" terminal can be connected to an external ground point such as the rack chassis.

2.5 Connecting the Input Signal

The signal is connected to the amplifier through a "SIM (Specialized Input Module) Card" located



Figure 2.3 – Close-up of SIM card

on the amplifier back panel (see **Figure 2.3**). The standard SIM card includes both an Unbalanced Input BNC jack and a Balanced Input "WECO" terminal block connector, an Input Select switch, and an Interlock – I/O Connector. See the **Applications** section for information on using the Interlock – I/O Connector.

Position the **Input Select** switch to the left to select the Unbalanced Input connector and to the right to select the Balanced Input connector. Note that **when the Input Select switch is in the right position, both Unbalanced and Balanced Input connectors are enabled**.

IMPORTANT: The Input Select switch also functions as a Ground Lift switch for the Unbalanced Input connector. If circulating currents/ground loops/60-Hz Hum occur when using the Unbalanced Input, move the Input Select switch to the right to lift the ground on the connector.

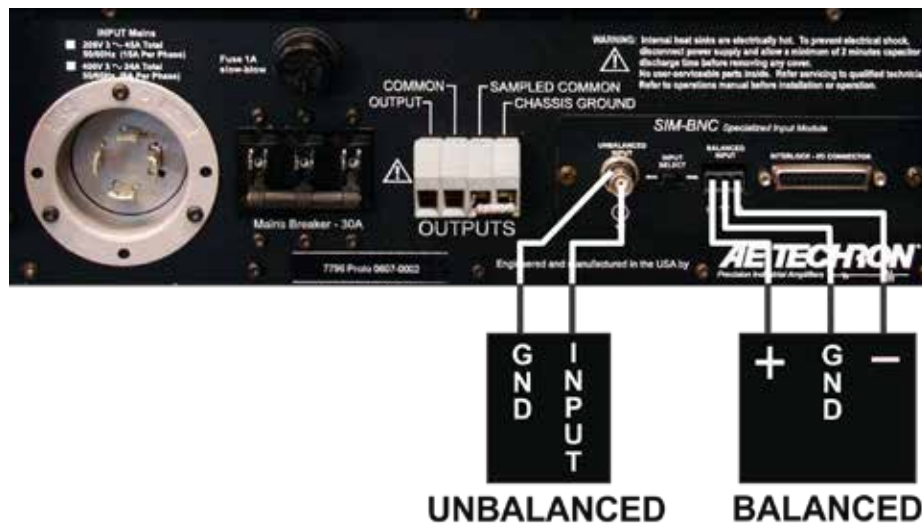
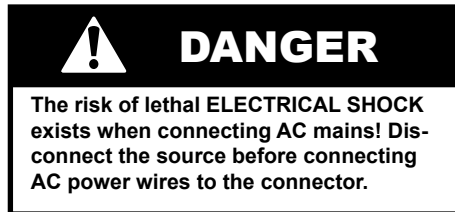

Figure 2.4 – Wiring for Unbalanced or Balanced Input Connector

Connect your input signal to the amplifier's unbalanced or balanced input connector as shown in **Figure 2.4**. Use cables that are high quality and shielded to minimize noise and to guard against possible feedback.



2.6 Connecting the AC Supply

The 7548/7794/7796/7796HC amplifier requires 3-phase wiring. Always operate the amplifier from proper AC mains. The 3-phase, 47 - 60 Hz voltage must be 208 VAC (or optionally 400 VAC, except model 7796HC) with no more than 10% variance above or below the line voltage. The amplifier will not operate properly outside these limits.

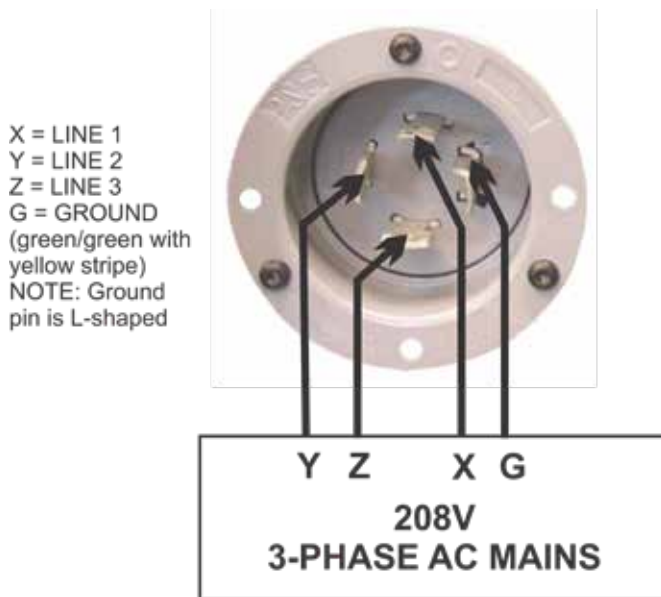

Figure 2.5 – 208V 3-Phase AC Mains Wiring

The amplifier includes a NEMA style locking AC connector as standard equipment. Connect the amplifier to the proper 3-phase AC mains with this connector. See **Figures 2.5 and 2.6** for proper AC Mains wiring. The connector then plugs into the amplifier.

2.7 Start-up Procedure

1. Turn down the level of your signal source.
2. Check to make sure the AC Mains Switch/Circuit Breaker is in the off position (DOWN).
3. Apply AC power to the amplifier.
4. Move the AC Mains Switch/Circuit Breaker to the on position (UP) to turn the amplifier ON. Wait for the amber READY and green RUN LEDs to illuminate.
5. Adjust the level of your input signal source to achieve the desired output level.
6. Use the Navigation Buttons to navigate through the various voltage and current measurement functions on the LCD display.

WARNING: If amplifier has been unused/inactive for 2 years or more, please startup connected to a low-voltage DC power supply. Start at 10% of the rated voltage and gradually increase to avoid damaging internal components.

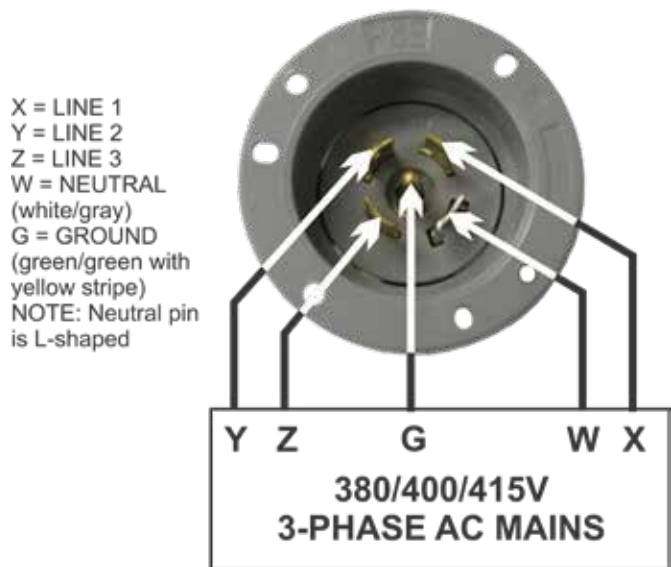

Figure 2.6 – 380/400/415V 3-Phase AC Mains Wiring

3 Amplifier Operation

3.1 Front-Panel Controls & Display

This section provides an overview of Front-Panel controls and display screen found on the 7548/7794/7796/7796HC amplifier. Please refer to **Figure 3.1** for item locations.

3.1.1 Input Buttons

Three Push Buttons on the amplifier front panel control basic operation of the amplifier.

Enable – For stand-alone amplifiers, Enable will release the amplifier from Stop mode and place the amplifier in Run mode (both Ready and Run LEDs will be lit). When the amplifier is placed in Run mode, the amplifier will amplify the input signal. If an amplifier is disabled using a Remote Standby application, the amplifier will be placed in Standby mode (both Ready and Standby LEDs will be lit). To return the amplifier to Run mode, release the Standby condition using the remote switch. See the **Applications** section of this manual for more information on remote amplifier operation.

In multi-amp systems that have been configured to start up in Standby mode, when the Enable button is pressed on one amplifier, the amplifier will be placed in Standby mode and remain in Standby mode until all amplifiers in the system have been Enabled. The system will automatically proceed to Run mode when all amplifiers in the system achieve Standby mode.

Stop – For stand-alone amplifiers, Stop will place the amplifier in Stop mode (both Standby and Stop LEDs will be lit). When the amplifier is part of a multi-amp system, pressing the Stop button on any amplifier in the system will place that amplifier in Stop mode and all other amplifiers in the system in Standby mode. When an amplifier is in Stop or Standby mode, the low-voltage transformer is energized but the high-voltage transformers are not.

Reset – For stand-alone amplifiers, when a fault condition occurs, the amplifier may be placed in Standby mode (Standby LED will be lit), depending on the amplifier configuration and the fault condition. To release the amplifier from Standby mode, clear the fault condition and then press the Reset button. If the amplifier is in Run mode when the fault condition occurs, pressing the Reset button will return the amplifier to Run mode. If the amplifier is in Stop mode when the fault condition occurs, pressing the Reset button will return the amplifier to Stop mode.

When the amplifier is part of a multi-amp system, pressing the Reset button on the amplifier reporting the fault condition will clear the condition and return all amplifiers to Run or Stop mode; pressing the Reset button on other amplifiers in the system will NOT clear the fault condition.

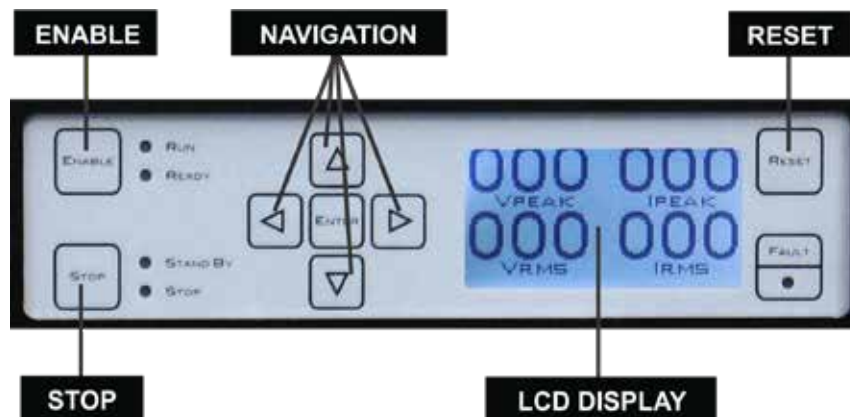

Figure 3.1 – Front Panel Controls and Display

3.1.2 Multi-Function LCD Display

The multi-function LCD display provides various displays of peak and RMS values for voltage and current measured directly from the amplifier output. The amplifier's model name is displayed on the model display screen in the display rotation.

If the amplifier experiences a fault condition, the LCD display will automatically change to display details of the fault condition and prescribed corrective actions.

On startup, the LCD Display will provide readings for all four measurements: Volts peak, Volts RMS, Current peak, and Current RMS. Use the Navigation buttons to scroll to other available displays, such as model name, peak voltage and peak current display, RMS voltage and RMS current display, or other combinations.

3.1.3 Navigation Buttons

The Navigation buttons provide four arrow keys to allow navigation through the different displays on the LCD display screen.

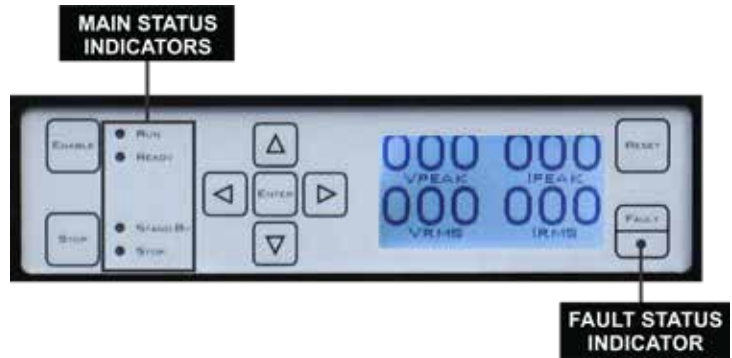

Figure 3.2 – Front Panel Indicators

NOTE: The Enter button has been provided for future expansion and has no function at this time.

3.2 Front-Panel Indicators

This section provides an overview of Front-Panel indicators found on the 7548/7794/7796/7796HC amplifier. Please refer to **Figure 3.2** for item locations.

3.2.1 Main Status Indicators

Four Main Status indicators are located on the amplifier's front-panel. These LEDs monitor the internal conditions of the amplifier and indicate the current state of operation. The chart in **Figure**

Figure 3.3 – Main Status Indicators for Stand-Alone Amplifiers

● ● ● Indicator is lit ● Indicator is not lit ○ Indicator may be lit

Main Status Indicators	State of Operation	Action Needed to Return to Run Mode
<ul style="list-style-type: none"> ● Run ● Ready ● Standby ● Stop 	<p>Run mode: The amplifier's high-voltage transformers are energized and the unit will amplify the input signal. Run mode is initiated by: (1) the Enable push button, or (2) when the amplifier powers up in Run mode (factory default). See the "Advanced Configuration" section for more information.</p>	N/A
<ul style="list-style-type: none"> ● Run ● Ready ● Standby ● Stop 	<p>Standby mode: Standby mode indicates that the amplifier is functioning properly and all Fault Status modes are clear, but it is being held in Standby by an external condition. As configured from the factory (Run mode on startup), the amplifier will enter Standby mode briefly after powering up, and then will move automatically into Run mode. In Standby mode, the amplifier's low-voltage transformer is energized but the high-voltage transformers are not.</p>	<p>If the amplifier remains in Standby mode, it is being held in Standby by remote control through the SIM Interlock I/O connector. Open the Enable/Standby switch to clear this remote Standby condition and return the amplifier to Run mode. See the "Applications" section of this manual for more information on remote amplifier operation.</p>
<ul style="list-style-type: none"> ● Run ● Ready ● Standby ● Stop 	<p>Stop mode: When the Stop button on the amplifier front panel is pressed, the amplifier will enter Stop mode. The amplifier may also enter Stop mode after powering up if the amplifier is configured to enter Stop mode on startup. In Stop mode, the amplifier's low-voltage transformer is energized but the high-voltage transformers are not.</p>	<p>To release the amplifier from Stop mode, press the Enable button.</p>

3.3 details the operational modes indicated by the Main Status indicators.

3.2.2 Fault Status Indicator

The Fault Status indicator is located on the amplifier front panel. This LED monitors the internal conditions of the amplifier and will illuminate when

a fault condition occurs. Depending on the fault condition and the configuration of the unit, the amplifier may be placed in Standby mode when a fault condition occurs. Refer to the chart in **Figure 3.4** to determine the fault condition being indicated and the action required to clear the fault condition.

Figure 3.4 – Fault Status Indicators for Stand-Alone Amplifiers

● ● ● Indicator is lit ● Indicator is not lit ○ Indicator may be lit

Main Status Indicators	Fault Status Reported on LCD Display	State of Operation	Action Needed to Clear Fault Condition and Return to Run Mode
<ul style="list-style-type: none"> ● Run ● Ready ● Standby ● Stop 	WARNING! OUTPUT DEVICE FAULT	Output Device Fault: This indicates that an Output Fault condition has occurred and the amplifier has been placed in Standby mode. The Fault indicator will light under two conditions: 1) High-frequency oscillation is causing high shoot-through current; or 2) An output transistor has shorted, causing the output fault condition.	This fault condition cannot be cleared using the front-panel Reset button. See the Troubleshooting section for more information on diagnosing and clearing this fault condition.
<ul style="list-style-type: none"> ● Run ● Ready ○ Standby ● Stop 	WARNING! OVERLOAD	Overload: This indicates that the output of the amplifier could not follow the input signal due to voltage or current limits. Under normal operation with the factory-default settings, an Overload condition will not place the amplifier in Standby mode. If the amplifier has been configured to be forced to Standby on Overload, the amplifier will be placed in Standby mode when the Overload condition occurs.	To remedy the Overload fault during operation, turn down the level of the input signal until the Fault indicator turns off. To clear an Overload fault condition when the amplifier is forced to Standby, turn down the level of the input signal, then push the Reset button.
<ul style="list-style-type: none"> ● Run ● Ready ● Standby ● Stop 	WARNING! OVERTEMP	Overtemp: The amplifier monitors the temperature inside the high-voltage transformers, low-voltage transformer and in the output stage heat sinks. The Fault indicator will light and the amplifier will be placed in Standby mode when the temperature sensors detect a condition that would damage the amplifier. If the Overtemp pulse is extremely short, as in the case of defective wiring or switches, the Fault LED may be lit too briefly to observe.	To reset after an Over Temp fault has occurred, make sure the amplifier fans in all amplifiers are running, and then remove the input signal from the system. Allow the fans to run for about 5 minutes until the system automatically returns to Run mode. Please see the “ Troubleshooting ” section for information on correcting the cause of an Over Temp fault condition.
<ul style="list-style-type: none"> ● Run ● Ready ● Standby ● Stop 	WARNING! OVERVOLTAGE	Overvoltage: This indicates that the AC mains voltage is more than +10% of nominal. The amplifier will be forced to Standby when an Overvoltage condition occurs. When the Overvoltage condition is cleared, the amplifier will automatically return to Run mode.	To clear an Overvoltage fault condition, the AC mains must be brought down to the nominal value. If the amplifier does not return to Run mode when the Overvoltage condition has cleared, the amplifier may require servicing. Please see the Troubleshooting section for more information.

3.2.3 Main Status Indicators for Multi-amplifier Systems

The Main Status indicators on each amplifier in a multi-amp system are used to determine the operational status of the amplifier. When evaluated

along with the statuses of other amplifiers in the system, the Main Status indicators can be used to determine the system status and the action required to return the system to Run mode. See **Figure 3.5**.

Figure 3.5 – Main Status Indicators for Multi-Amplifier Systems

● ● ● Indicator is lit ● Indicator is not lit ○ Indicator may be lit

Main Status of One or More Amps in the System	Main Status of Other Amps in the System	State of Operation	Action Needed to Return to Run Mode
● Run ● Ready ● Standby ● Stop	● Run ● Ready ● Standby ● Stop	Run mode: All of the amplifiers in the system are in Run mode. The amplifiers' high-voltage transformers are energized and the system will amplify the input signal.	N/A
● Run ● Ready ● Standby ● Stop	● Run ● Ready ● Standby ● Stop	Remote Standby Condition: All of the amplifiers in the system are being held in Standby mode by an external condition. In Standby mode, the amplifiers' low-voltage transformers are energized but the high-voltage transformers are not.	If the amplifiers remain in Standby mode, the system is being held in Standby by remote control through the SIM Interlock I/O connector. Open the Enable/Standby switch to clear this remote Standby condition and return the system to Run mode. See the Applications section of this manual for more information on remote amplifier operation.
● Run ● Ready ● Standby ● Stop	● Run ● Ready ● Standby ● Stop	System Not Ready: If one or more of the amplifiers has no LEDs lit, the amplifier has no power or has not been turned on, and the other amplifiers in the system will be held in Standby mode. In Standby mode, the amplifier's low-voltage transformer is energized but the high-voltage transformers are not.	Make sure all amplifiers have AC power and have been turned on. When all amplifiers attain Standby status, all amplifiers in the system will simultaneously be placed in Run mode.
● Run ● Ready ● Standby ● Stop	● Run ● Ready ● Standby ● Stop	Stop mode: When the Stop button on any amplifier in the system is pressed, that amplifier will enter Stop mode and all other amplifiers will enter Standby mode. The system may also enter Stop mode after powering up if one or more amplifiers in the system is configured to enter Stop mode on startup. In Stop mode, the amplifier's low-voltage transformer is energized but the high-voltage transformers are not.	To release the system from Stop mode, press the Enable button on the amplifier displaying the Stop mode status.

3.2.4 Fault Status Indicators for Multi-Amp Systems

Four different fault error messages may be displayed on the amplifier's front panel LCD screen when a fault condition occurs. All amplifiers in the

system may be placed in Standby mode when a fault condition occurs, depending on the fault condition and the configuration of the system. Typically, the system can be released from Standby mode by pressing the Reset button on the amplifier dis-

playing the Fault status. Refer to the chart below to determine the fault condition being indicated and the action required to clear the fault condition and return the system to Run mode.

Figure 3.6 – Fault Status Indicators for Multi-Amplifier Systems

● Indicator is lit ● Indicator is lit ● Indicator is lit ● Indicator is not lit ○ Indicator may be lit

One or More Amps in System		Main Status Indicators of Other Amps in System	State of Operation	Action Needed to Clear Fault Condition and Return to Run Mode
Main Status Indicators	Fault Status Reported on LCD Display			
<ul style="list-style-type: none"> ● Run ● Ready ● Standby ● Stop 	<p>WARNING! OUTPUT DE- VICE FAULT</p>	<ul style="list-style-type: none"> ● Run ● Ready ● Standby ● Stop 	<p>Output Device Fault status: This indicates that an Output Fault condition has occurred in the amplifier displaying the Fault status, and the system has been placed in Standby mode. The Fault indicator will light under two conditions: 1) High-frequency oscillation is causing high shoot-through current; or 2) An output transistor has shorted, causing the output fault condition.</p>	<p>This fault condition cannot be cleared using the front-panel Reset button. See the Troubleshooting section for more information on diagnosing and clearing this fault condition.</p>
<ul style="list-style-type: none"> ● Run ● Ready ○ Standby ● Stop 	<p>WARNING! OVERLOAD</p>	<ul style="list-style-type: none"> ● Run ○ Ready ○ Standby ● Stop 	<p>Overload status: This indicates that the output of the system could not follow the input signal due to voltage or current limits. Under normal operation with the factory-default settings, an Overload condition will not place the system in Standby mode. If the system has been configured to be forced to Standby on Overload, the system will be placed in Standby mode when the Fault indicator lights.</p>	<p>To remedy the Overload fault during operation, turn down the level of the input signal until the Overload indicator turns off. To clear an Overload fault condition when the amplifier is forced to Standby, turn down the level of the input signal, then push the Reset button on the amplifier(s) displaying the Overload status.</p>
<ul style="list-style-type: none"> ● Run ● Ready ● Standby ● Stop 	<p>WARNING! OVERTEMP</p>	<ul style="list-style-type: none"> ● Run ● Ready ● Standby ● Stop 	<p>Overtemp status: Each amplifier in the system monitors the temperature inside the high-voltage transformers, low-voltage transformer and in the output stage heat sinks. The Overtemp indicator will light and the system will be placed in Standby mode when the temperature sensors detect a condition that would damage the amplifier system. If the Overtemp pulse is extremely short, as in the case of defective wiring or switches, the Fault LED may be lit too briefly to observe.</p>	<p>To reset after an Overtemp fault has occurred, make sure the amplifier fans in all amplifiers are running, and then remove the input signal from the system. Allow the fans to run for about 5 minutes until the system automatically returns to Run mode. Please see the Troubleshooting section for information on correcting the cause of an Overtemp fault condition.</p>

One or More Amps in System		Main Status Indicators of Other Amps in System	State of Operation	Action Needed to Clear Fault Condition and Return to Run Mode
Main Status Indicators	Fault Status Reported on LCD Display			
<ul style="list-style-type: none"> ● Run ● Ready ● Standby ● Stop 	<p>WARNING! OVERVOLTAGE</p>	<ul style="list-style-type: none"> ● Run ● Ready ● Standby ● Stop 	<p>Overvoltage status: This indicates that the AC mains voltage is more than +10% of nominal. All amplifiers in the system will be forced to Standby when an Overvoltage condition occurs. When the Overvoltage condition is cleared, the system will automatically return to Run mode.</p>	<p>To clear an Overvoltage fault condition, the AC mains must be brought down to the nominal value. If the system does not return to Run mode when the Overvoltage condition has cleared, one or more amplifiers may require servicing. Please see the Troubleshooting section for more information.</p>

3.3 Back-Panel Controls and Connectors

This section provides an overview of Back-Panel controls and connectors found on the 7548/7794/7796/7796HC amplifier. Please refer to **Figure 3.7** for visual locations.

AC Power Connector - This is a NEMA style twist lock, 4 pin (208V) or 5-pin (400V), three-phase connector. See **Section 2.6, “Connecting the AC Supply,”** for terminal connections.

Low-Voltage Fuse - This is a 1A slow blow type 600-volt rated fuse.

AC Mains Switch/Circuit Breaker - This dual function power switch and circuit breaker opens all legs of the AC mains. The rating is 20A (7548) or 30A (7794/7796/7796HC) for 208 volts.

Output Terminal Block - Connect output lines from the load to this 4-terminal block. It accepts up to #4 AWG wire. Drive the load in the Controlled Current mode using the OUTPUT terminal and the SAMPLED COMMON terminal only.

BNC Input Connector - This input option provides a standard unbalanced input.

Input Selector Switch - This switch selects which input connector is active, the BNC or Weco.

Weco Input Connector - This input option provides a balanced input.

Interlock Connector - This 25-pin, D-sub connector is used for interlocking and combining functions in a multi-amp system. It can also be used for remote control and monitoring applications (see the **Applications** section for more information).

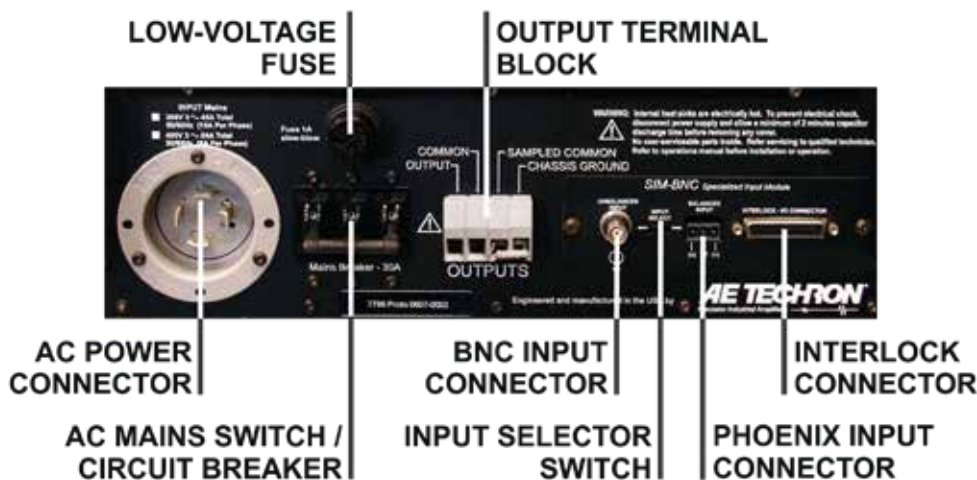

Figure 3.7 – Back Panel Controls and Connectors

4 Advanced Configuration

The 7548/7794/7796/7796HC amplifier was designed to offer exceptional power and versatility in operation. You can choose from a range of field-configurable options, including:

- Operate as a stand-alone amplifier or as part of a multiple-amplifier system.
- Select DC-coupled or AC-coupled operation.
- Select Controlled-Current or Controlled-Voltage modes of operation.
- Enable a 50-kHz low-pass filter.
- Change the maximum amplifier gain from 20:1 to 6:1.
- Configure the amplifier to enter Standby on startup
- Configure the amplifier to enter Standby when an overload condition occurs.
- Configure the bi-level power supply for use in high voltage applications, high current applications, or for applications requiring mid-level amounts of both voltage and current.

Configurations settings are made using the eight DIP switches located on the amplifier's main circuit board, using shunts across jumper pins located on the main circuit board, or by plug and switch settings on the amplifier's power supply board. These controls can be used to alter the amplifier operation from the factory defaults.



4.1 Factory Defaults

Your 7548/7794/7796/7796HC amplifier has been configured to operate to the following factory defaults:

- Master/ Single mode
- DC-coupled operation
- Controlled-Voltage mode
- CC1 Compensation network
- Low-pass filter disabled
- Power supply configured for mid-level operation
- Power-Up into Ready mode
- Standby Mode on Overload disabled

If you need to make changes to your amplifier's configuration, please follow the instructions contained in this chapter for accessing the main board DIP switches and jumpers, and the power supply board settings..

The main and power supply boards can be accessed by removing the amplifier front panel. To remove the amplifier front panel, complete the steps detailed in the following section.

	WARNING
<p>Do not attempt to access the Main Board while the amplifier is running. Turn the amplifier off and disconnect the AC Mains before removing the amplifier front panel.</p>	
	CAUTION
<p>After turning the amplifier off, let the unit sit for 3-5 minutes before removing the front panel. This will allow the electrical charge in the Power Supply capacitors to discharge.</p>	

4.2 Accessing the Main Board

The amplifier Main Board can be accessed by removing the amplifier front panel.

IMPORTANT: Before removing the Front Panel, make sure the amplifier is turned off for at least 3-5 minutes and the AC mains are disconnected.

Tool Required

Torx T15 driver

Procedure

1. Turn the power to the amplifier "OFF".
2. Remove the four hex-head screws, located along the left and right edges of the amplifier front panel using a Torx T15 driver.
3. Remove the front cover by pulling straight towards you.

4.3 Configuration Settings Controlled by DIP Switches

The 7548/7794/7796/7796HC amplifier provides eight DIP switches located on the amplifier main

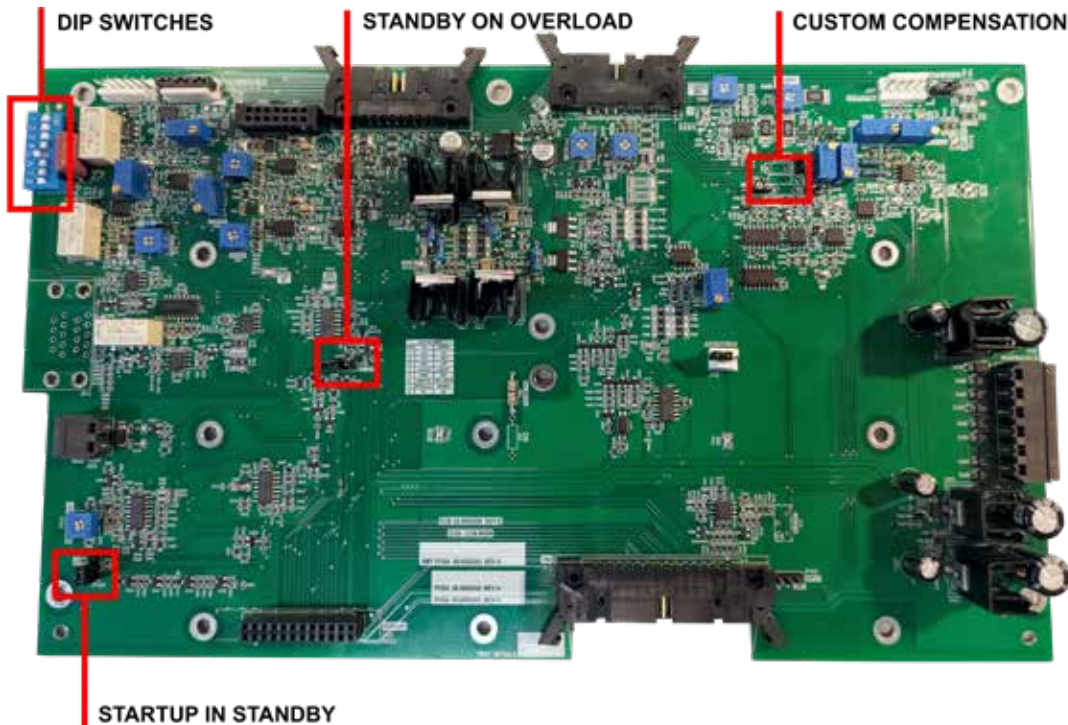

Figure 4.1 – Main Board Configuration Locations

	1 2 3 4 5 6 7 8			
	DIP SWITCH SETTINGS	UP	DOWN	
Controlled-voltage or controlled-current operation	1 OPERATION (CV / CC)	CV	CC	Compensation network (for controlled-current operation)
Enable 50 kHz low-pass filter	2 COMPENSATION (CC1 / CC2)	CC1	CC2	
Enable electronic gain matching (for parallel multi-amp operation)	3 LOW PASS FILTER	OFF	ON	Gain selection (20 / 6)
	4 GAIN (20 / 6)	20	6	
	5 ELECTRONIC GAIN MATCHING	ON	OFF	Multi-amp configuration
	6 MASTER / FOLLOWER	MASTER	FOLLOWER	
Low (line-level) input or high input (up to 180V)	7 VOLTAGE INPUT (LOW / HIGH)	LOW	HIGH	DC enable or DC block
	8 DC / AC COUPLING	DC	AC	
	RED = FACTORY DEFAULT			

Figure 4.2 – DIP Switch Settings and Descriptions

board. Most configuration settings can be made using these DIP switches.

Please refer to **Figure 4.1** for main board DIP switch locations. See **Figure 4.2** for DIP switch settings and descriptions.

SW#1: Operation (CV/CC)

When the Operation DIP switch is in the UP position (default), the amplifier will operate in Controlled-Voltage mode, and the amplifier's output voltage will be controlled by its input voltage sig-

nal. When this switch is in the DOWN position, the amplifier will operate in Controlled-Current mode, and the amplifier's output current will be controlled by its input voltage signal.

IMPORTANT: Controlled-Current operation requires the use of a compensation network, and the amplifier's default compensation network may not be suitable for your application. For more information on Controlled-Current operation, including how to determine and configure a custom compensation network, see the **Applications** section.

	<h2 style="margin: 0;">CAUTION</h2>
<p>In Controlled-Current Mode, the load is part of the amplifier circuit, and the relationship of the load to the amplifier is critical. For proper and safe operation in Controlled-Current mode, you must observe the following guidelines:</p> <ol style="list-style-type: none"> 1. Properly attach a load before operating the amplifier. 2. DO NOT use a blocking capacitor. The load must have a DC path. 3. Never leave the load open. If you feel the load must be fused, which could lead to a potential open circuit, please contact AE Techron Technical Support. 4. Make sure the load has some inductive component. 5. Provide appropriate compensation for the load. 6. If oscillation occurs, turn off the amplifier immediately. <p>Failure to follow these guidelines may result in damage to the amplifier or load.</p>	

SW#2: Compensation (CC1/CC2)

When a 7548/7794/7796/7796HC amplifier is used in Controlled-Current mode, the current control loop is tuned with an RC network. Place the Compensation DIP switch in the **Up** position (default) to enable the factory-installed RC network (**CC1**). This network consists of a 68.1 kΩ resistor in series with a 47 nF capacitor. Place the DIP switch in the **Down** position to select **CC2** network. This network is unpopulated, but can be populated with a custom compensation network to fit your requirements. For more information on Controlled-Current operation and installing a custom compensation network, see the “**Applications**” section of this manual.

SW#3: Low-Pass Filter

The Low Pass Filter function inserts a 50 kHz (3-dB down) low-pass filter at the amplifier input to ensure that signals above 50 kHz are not amplified.

Place the Low-Pass Filter DIP switch in the **Up** position (default) to disable the low-pass filter. To enable the low-pass filter, place the DIP switch in the **Down** position.

SW#4: Gain (20/6)

When the Gain DIP switch is in the **Up** position (default), the amplifier’s maximum gain will be 20:1. Placing the DIP switch in the **Down** position will change the amplifier’s maximum gain to 6:1.

SW#5: Electronic Gain Matching

The Electronic Gain Matching function serves to minimize circulating currents when multiple amplifiers are used in a parallel configuration. When enabled, the Electronic Gain Matching function progressively increases impedance from the voltage gain as current increases, up to a maximum 0.10-ohm increase. This allows the amplifiers to operate in parallel without the use of separate ballast resistors in multi-amp applications up to 20 kHz. For more information on multi-amplifier system configuration and operation, see the **Applications** section.

When this switch is in the **Down** position (default), Electronic Gain Matching is disabled. When the Electronic Gain Matching DIP switch is in the **Up** position, the Electronic Gain Matching function is enabled.

SW#6: Master/Follower

When the Master/Follower DIP switch is in the **Up** position (default), the amplifier will function as a stand-alone amplifier or as a Master amplifier in a multi-amp system. When this switch is in the **Down** position, the amplifier will function as a Follower amplifier in a multi-amp system.

For more information on multi-amplifier system configuration and operation, see the **Applications** section.

SW#7: Voltage Input (Low/High)

When the Voltage Input DIP switch is in the **Up** position (default), the amplifier can be configured for use with alternate multi-amp connectors in a multi-amp system (not available on 7548, 7794, 7796, or 7796HC models). When this switch is in the **Down** position, the amplifier can be configured for use with standard multi-amp connectors in a multi-amp system.

SW#8: DC/AC Coupling

When the DC/AC Coupling DIP switch is in the **Up** position (default), the amplifier can receive and amplify both DC and AC signal. When this switch is in the **Down** position, a 2-Hz high-pass filter on the inputs prevents the transmission of DC signal.

4.4 Configuration Settings Controlled by Jumpers

The following settings can be made via jumper settings on the Main Board. Please refer to **Figure 4.1** for main board jumper locations.

Custom Compensation Network

When the 7548/7794/7796/7796HC amplifier is used in Controlled-Current mode, the current control loop is tuned with an RC network. The factory default network (CC1) provides 68.1k ohm resistance and 47 nF capacitance. If this default network is not adequate for your application and load, CC2 can be used to install a custom RC network on the amplifier main board.

For information on installing a custom RC network, please see the topic “**Controlled Current Operation**” in the **Applications** section of this manual.

Enable/Stop on Power-up

The 7548/7794/7796/7796HC amplifier will power-up to Run Mode when a shunt is placed across pins 1 and 2 on the Enable/Stop jumper (default setting). See **Figure 4.3**. To cause the 7548/7794/7796/7796HC amplifier to enter Standby (Stop Mode) on power-up, place the shunt across pins 2 and 3.

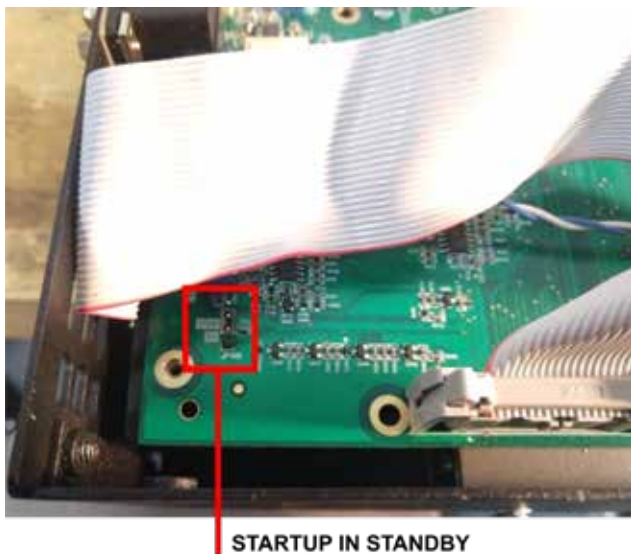

Figure 4.3 – Enable/Stop on Power-up Configuration

Standby on Overload

The 7548/7794/7796/7796HC's IOC (Input/Output Comparator) Distortion Alert circuit continuously compares the waveforms observed at the amplifier input and output. When a distortion between the two waveforms of more than 0.5% occurs, the IOC circuit will activate, and the Overload LED will light, but the amplifier will continue to operate. To configure the amplifier to move to Standby (Fault mode) when the IOC circuit is activated, locate the Overload Latch (see **Figure 4.4**) and place a shunt across the two pins of the jumper.

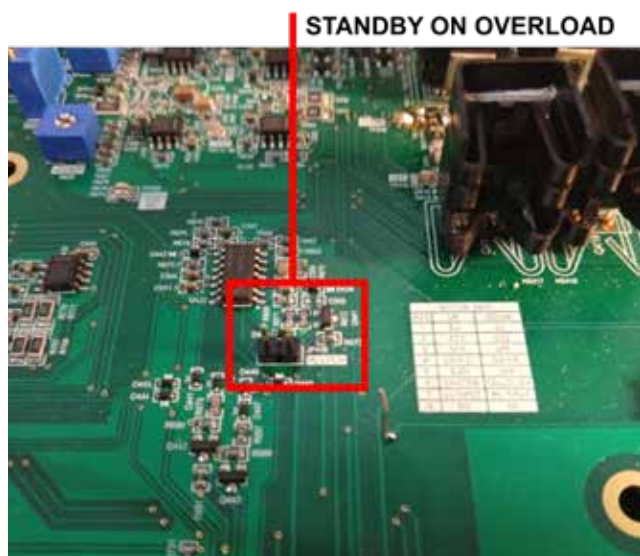

Figure 4.4 – Configure for Standby (Fault Mode) on Overload

4.5 Adjusting the Bi-Level Power Supply Switch

The amplifier offers three Bi-Level switch settings: Automatic, High, or Low. The user can select between settings via a switch on the Power Supply Board. The Power Supply Board is a horizontal board located below the main and display boards. To access the Bi-Level Power Supply Switch, complete the following steps to remove the front panel and access the bi-level power supply switch.

IMPORTANT: Before removing the Front Panel, make sure the amplifier is turned off for at least 3-5 minutes and the AC mains are disconnected.

1. Turn the power to the amplifier “OFF”.
2. Remove the four hex-head screws, located along the left and right edges of the amplifier front panel using a Torx T15 driver.
3. Remove the front cover by pulling straight towards you.
4. Locate the Bi-level Power Supply Switch as shown in **Figure 4.5**.
5. **Adjust the switch setting based on your operating requirements, as described below:**
 - **AUTO** (left position) – power supply will switch depending on voltage requirements (factory-default setting).
 - **LOCKED LOW** (center position) – power supply will remain in low-voltage mode.
 - **LOCKED HIGH** (right position) – power supply will remain in high-voltage mode.

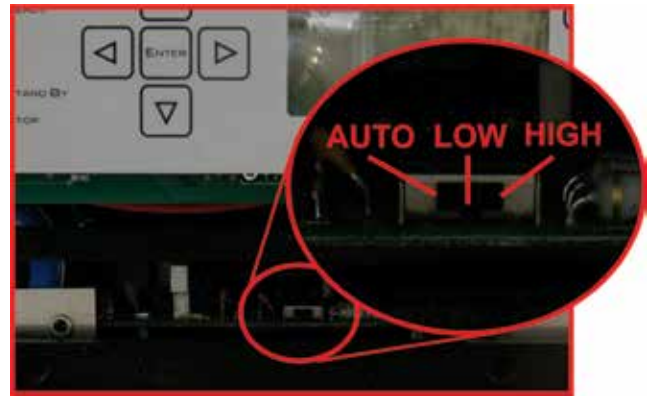

Figure 4.5 – Bi-Level Power Switch Location

5 Applications

5.1 Remote Status and Control using the SIM Interlock I/O Connector

The procedures outlined in this section assume competence on the part of the reader in terms of amplifier systems, electronic components, and good electronic safety and working practices.

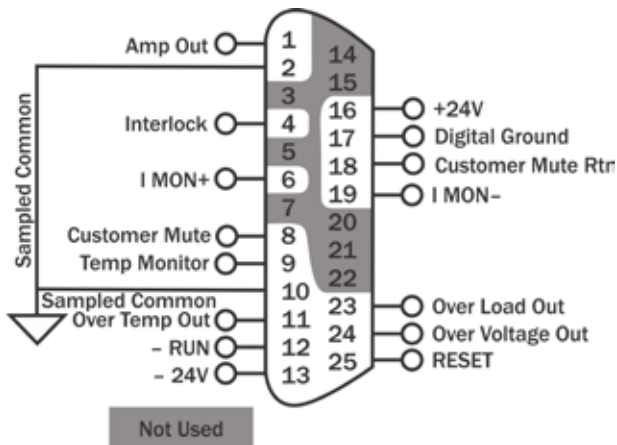

Figure 5.1 – Remote Status and Control Pinouts on 25-pin D-Sub Connector (SIM card)

AE Techron 7548, 7794, 7796 and 7796HC amplifiers come with a SIM-BNC input module that also contains a female, 25-pin D-Sub connector. This connector can be used to provide remote control and monitoring of the amplifier.

The information provided here will instruct you in the wiring of several control and status applications including:

- Remote Run / Standby
- Amplifier status: Run, Over-temperature, Overload, Overvoltage; and Reset after Overload error
- Remote Enable/Standby
- Customer mute
- Current monitor
- Temperature monitor

Figure 5.1 maps the pins used for these applications.

For a detailed chart of all DB-25 pinouts, see “Appendix 1.”

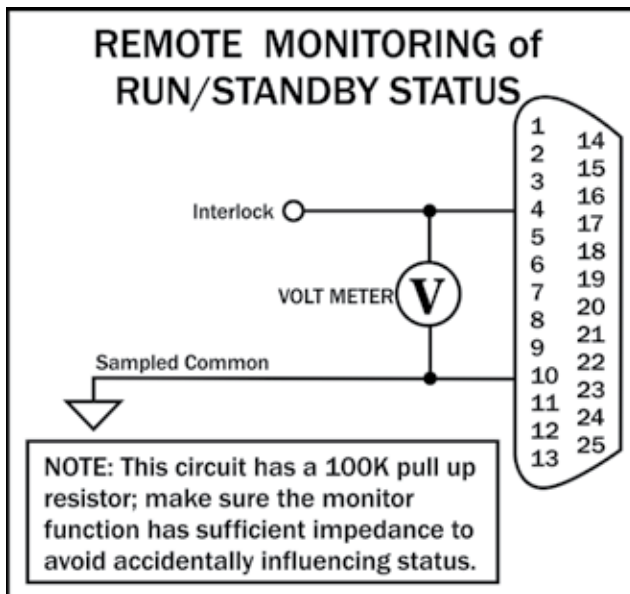

Figure 5.2 – Remote Run/Standby Monitor

5.1.1 Remote Run/Standby Status Monitor

Using the SIM-BNC Interlock connector located on the back panel of the amplifier, you can remotely monitor the Run/Standby status of the amplifier.

Remote Run/Standby Status

Purpose: Use a voltage meter to monitor the status of the amplifier to determine if the amplifier is in a “Run” or “Standby” state.

Method: Connect a voltage meter to monitor the circuit voltage. Connect across PIN 4 (Interlock) and PIN 10 (Sampled Common).

When the voltage meter reads greater than 10V, the amplifier is in the Run state; when the meter reads less than 10V, the amplifier is in the Standby state. See **Figure 5.2**.

Signal Type: DC

Level when Asserted: >10 V

Level when Deasserted: <10 V

IMPORTANT: This circuit has a 100K pull-up resistor. Make sure the monitor function has sufficient impedance to avoid accidentally influencing status.

5.1.2 Remote Amplifier Status and Reset

The SIM Interlock I/O Connector can be used to create a circuit to monitor remotely one or more amplifier conditions, including Run status, Over-temperature, Overload and Overvoltage. The circuit can also be constructed to allow remote reset of the amplifier when it is forced to Standby due to Overload conditions.

Use a male, 25-pin D-Sub connector and high-quality wire to build the circuit. **Figure 5.3** schematic details the circuit and components required for all status and reset functions.

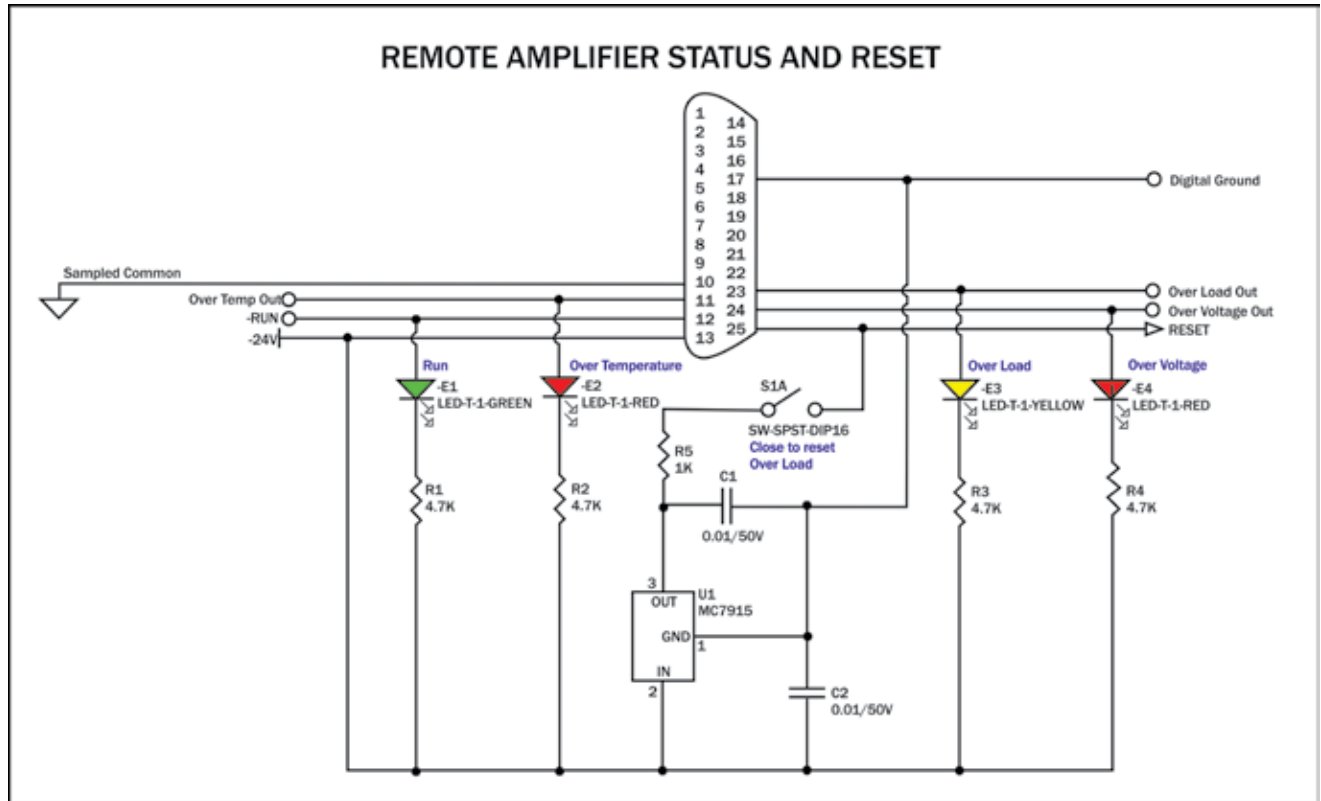

Figure 5.3 – Remote Status and Reset Schematic

Remote Signal of Over Temperature Condition

Purpose: LED, when lit, signals Over Temperature condition.

Method: Use a 6mA series resistor of 4.02 Kohm for LED or OPTO, tie OverTemp Out (PIN 11) to -24V source (PIN 13).

Signal Type: DC

Level when Asserted: -24V

Level when Deasserted: 0V

Note: When amp is normal, this pin is pulled to -24V through a 47.5K-ohm resistor; when amp is in Overtemp state, transistor Q37 turns on and sources chassis ground as an output. Do not exceed 20 milliamps.

An Overtemp condition will force the amp to Standby. The amplifier will automatically move to Run when temperature cools to operating levels.

Remote Signal of Run Condition

Purpose: LED, when lit, signals Run state.

Method: Use a 6mA series resistor of 4.02K-ohm for LED or OPTO, tie Run (PIN 12) to –24V source (PIN 13).

Signal Type: DC

Level when Asserted: –24V

Level when Deasserted: 0V

Remote Signal of Overload Condition

Purpose: LED, when lit, signals Overload condition.

Method: Use a 6mA series resistor of 4.02K-ohm for LED or OPTO, tie OverLoad Out (PIN 23) to –24V source (PIN 13).

Signal Type: DC

Level when Asserted: –24V

Level when Deasserted: 0V

Note: When amp is normal, this pin is pulled to –24V through a 47.5K-ohm resistor; when amp is in Overload state, transistor Q36 turns on and sources chassis ground as an output. Do not exceed 20 milliamps.

An Overload condition will not place the amplifier in Standby when operating with the factory default settings. In order to clear the fault condition, reduce the input levels until the Fault LED turns off. However, if the Standby Mode on Overload option is set, an Overload condition will force amp to Standby. To return the amplifier to Run mode, reduce the input signal level, then trigger a Reset command using the front-panel Reset button or a remote amplifier Reset command.

Remote Signal of OverVoltage Condition

Purpose: LED, when lit, signals Overvoltage condition.

Method: Use a 6mA series resistor of 4.02K-ohm for LED or OPTO, tie OverVoltage Out (PIN 24) to –24V source (PIN 13).

Signal Type: DC

Level when Asserted: –24V

Level when Deasserted: 0V

Note: When amp is normal, this pin is pulled to –24V through a 47.5K-ohm resistor; when amp is in Overvoltage state, transistor Q29 turns on and sources chassis ground as an output. Do not exceed 20 milliamps.

Reset from Standby

Purpose: Switch, when thrown, returns amp to Run condition after Overload conditions.

Method: Use a dry-contact switch, voltage regulator (MC7915), and two 0.01/50V capacitors; wire the circuit as shown (above). Assert 15V for at least 100 ms to clear the error condition.

Signal Type: DC

Level when Asserted: –15V

Level when Deasserted: 0V

Note: Tie to PIN 13 (–24V dc) and create a –15V dc source; <2mA required for reset. Connect the –15V dc source to PIN 25 (Reset) through a 1K buffer resistor to reset.

5.1.3 Remote Enable/Standby

Using the SIM-BNC Interlock connector located on the back panel of the amplifier, you can remotely Enable the amplifier and/or place the unit in Standby mode. See **Figure 5.4**.

Remote Enable/Standby

Purpose: Use a switch or optocoupler to remotely disable the amplifier and place it in Standby mode. Also, return the amplifier from Standby mode to the Run condition.

Method: Short PIN 4 of amplifier to Digital Ground (PIN 17) using a dry contact switch or optocoupler. In multi-amp applications, a switch can be used for Parallel systems, but an optocoupler must be used for Series systems. Multiple amplifiers (sharing the same Sampled Common power connections) can be simultaneously forced to Standby by daisy-chaining Interlock (PIN 4) across amps.

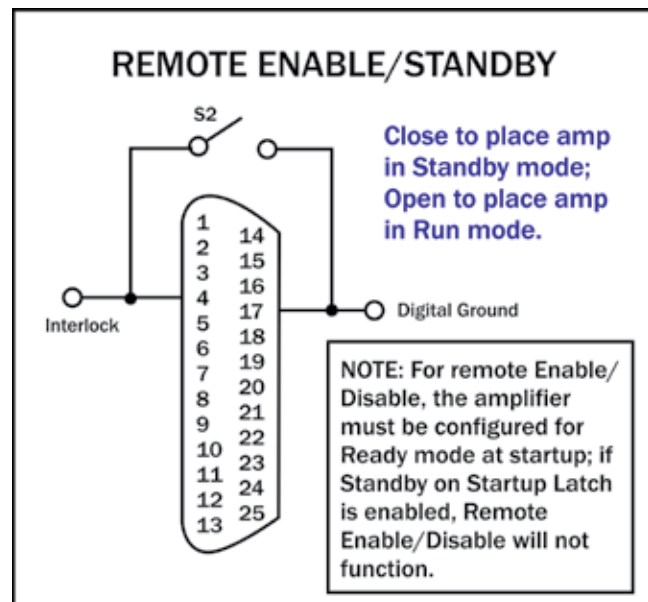

Figure 5.4 – Remote Enable/Standby

When Interlock (PIN 4) is shorted to Digital Ground (PIN 17), the amplifier is placed in Standby mode. When switch is open, the amplifier is released to the Run condition.

Signal Type: DC

Level when Asserted: 0 to 8 V

Level when Deasserted: 10 to 15 V

IMPORTANT: The amplifier must be configured for Ready mode at startup (factory default) or the Run button must be pressed at the amplifier front panel at startup. The Remote Enable/Standby circuit will not function if the Startup to Standby Latch has been activated on the amplifier.

5.1.4 Remote Monitoring of Current

Using the SIM-BNC Interlock connector located on the back panel of the amplifier, you can remotely monitor current output.

Remote Monitoring of Current Output

Purpose: Use a voltage meter to monitor output current.

Method: Connect a voltage meter to monitor the output current being produced by the amplifier. Connect across PIN 6 (I MON+) and PIN 10 (Sampled Common). See **Figure 5.5**.

Signal Type: AC

Level when Asserted: 20A/V

Level when Deasserted: 0V

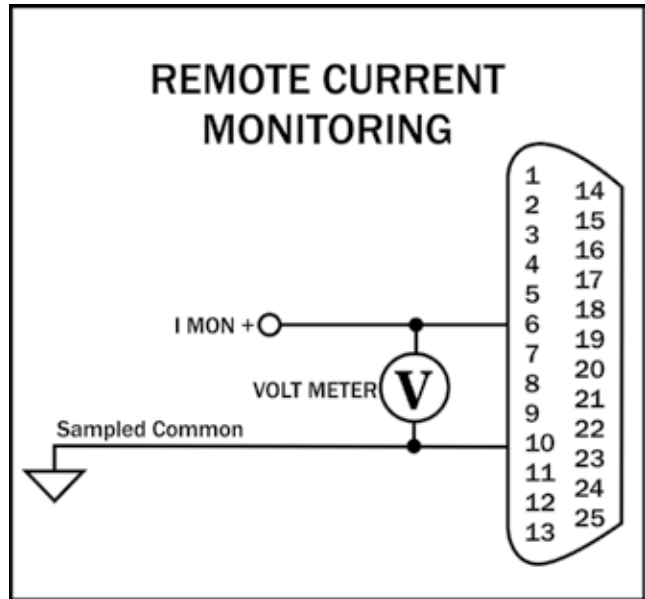

Figure 5.5 – Remote Current Monitoring

Remote Monitoring of Current Output - Alternate Method

Purpose: Use a voltage meter to monitor output current when output is not balanced.

Method: Connect a voltage meter to monitor the output current being produced by the amplifier. Connect across PIN 6 (IMON+) and PIN 19 (IMON-). See **Figure 5.6**.

Signal Type: AC

Level when Asserted: 10A/V

Level when Deasserted: 0V

CAUTION: To avoid ground loops, isolation from ground must be provided. Use of a differential probe is recommended.

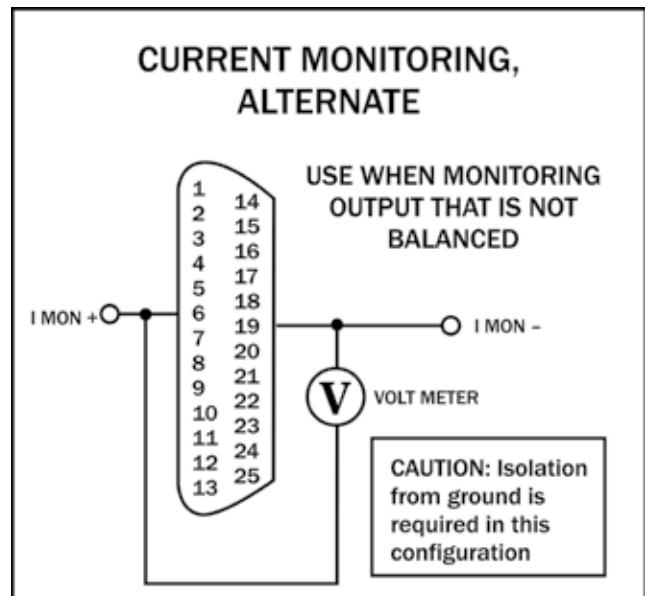

Figure 5.6 – Remote Current Monitoring, Alternate Method

5.3.7 Remote Monitoring of Temperature

Using the SIM-BNC Interlock connector located on the back panel of the amplifier, you can remotely monitor the temperature at the heat-sinks of the amplifier.

Remote Monitoring of Temperature

Purpose: Use a voltage meter to monitor temperature at the heat-sinks.

Method: Connect a voltage meter to monitor the temperature at the heatsinks of the amplifier. Connect across PIN 9 (TEMP MONITOR) and PIN 10 (Sampled Common). See **Figure 5.7**.

Signal Type: DC

Level: (VDC * 100) - 273 = degrees Celsius

IMPORTANT: This circuit has a 1K build-out resistor. Make sure the monitor function has sufficient impedance to avoid accidentally influencing status. Most digital multimeters have an input impedance of 1 megohm and would work well for this application.

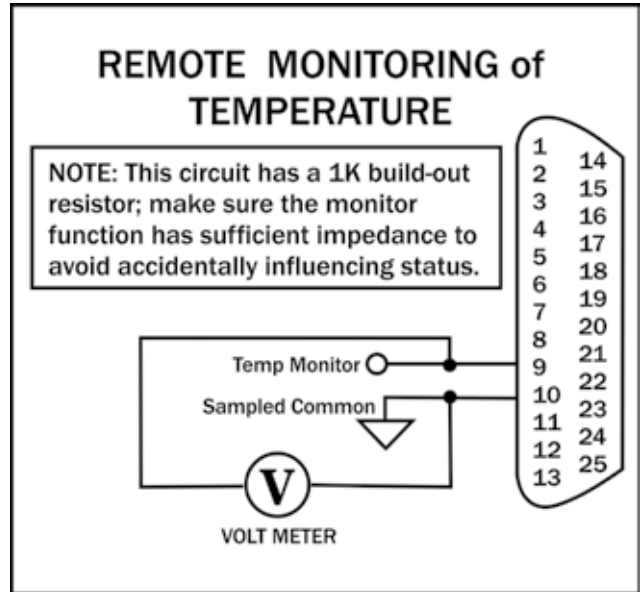

Figure 5.7– Remote Monitoring of Temperature

Blanking Circuit Activation

Purpose: Activate the blanking circuit that shuts down the amplifier output stage in less than 10 μs.

Method: Build a switchable circuit using an external, isolated 5V power supply that can apply a +5V signal to PIN 8. Connect across PIN 8 (Blanking) and PIN 18 (Blanking Return). See **Figure 5.8**.

Signal Type: DC

Level when Asserted: 5-6 Vdc

Level when Deasserted: 0 Vdc

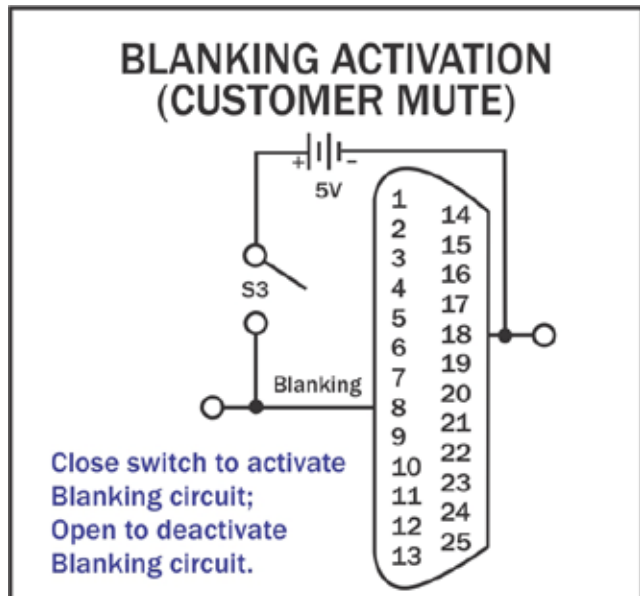

Figure 5.8 – Blanking Activation

5.2 Controlled Current Operation

The procedures outlined in this section assume competence on the part of the reader in terms of amplifier systems, electronic components, and good electronic safety and working practices.

5.2.1 Controlled-Voltage vs. Controlled-Current Modes of Operation

AE Techron 7548, 7794 and 7796 amplifiers can be field-configured to operate as **Voltage Amplifiers** (Voltage-Controlled Voltage Source) or as **Transconductance Amplifiers** (Voltage-Controlled Current Source). The mode selection is made via a jumper setting located on the amplifier main board. See the **Advanced Configuration** section for more information.

When configured as a **Controlled-Voltage** source (voltage amplifier), the amplifier will provide an output voltage that is constant and proportional to the control (input) voltage. If the load's impedance changes, the amplifier will seek to maintain this ratio of input to output voltage by increasing or decreasing the current it produces, as long as it is within the amplifier's ability to create the required current. Use this mode if you want the output voltage waveform to be like the input waveform (see **Figure 5.9**).

Conversely, when configured as a **Controlled-Current** source (transconductance amplifier), the amplifier will provide an output current that is constant and proportional to the control (input) voltage-

age. If the load's impedance changes, the amplifier will seek to maintain this transconductance (ratio of input voltage to output current) by increasing or decreasing the voltage it produces, as long as it is within the amplifier's ability to create the required voltage. Use this mode if you want the output current waveform to be like the input waveform (see **Figure 5.10**).

5.2.2 Safety and Operation Considerations for Controlled Current Operation

When an AE Techron amplifier is configured as a Controlled Current source, care needs to be exercised in its operation. **Any voltage controlled current source should never be turned on without a load, (with some impedance, real or effective) connected to its output terminals.**

When asked to operate in this way, any current source (including an AE Techron amplifier) will increase its output voltage in an attempt to drive the requested current into the load. In an open-circuit condition, creating current flow will be impossible. The current source will increase its output voltage until it reaches its voltage limit. This is a potentially dangerous condition for both the AE Techron amplifier and for any user who might come in contact with the amplifier output terminals.

When operating in Controlled Current (CC) mode, a compensation circuit is required to ensure accurate output current. Since the load is a critical circuit component in CC mode, the inductive and

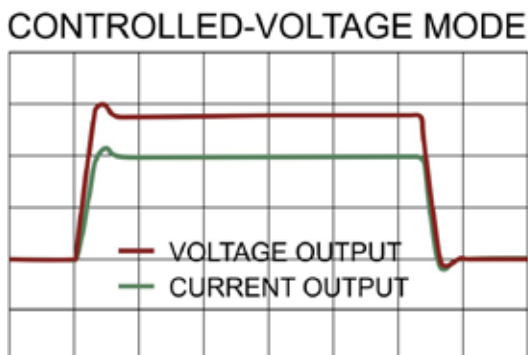

Figure 5.9 – Input to Output Comparison, Controlled-Voltage Operation

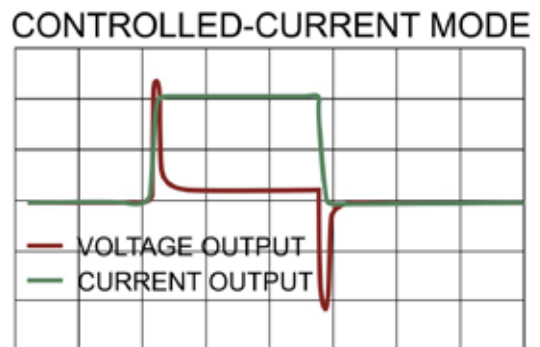

Figure 5.10 – Input to Output Comparison, Controlled-Current Operation

resistive values of the load will determine the required compensation values. While the factory-default compensation setting will be sufficient for some applications, the compensation setting may also be adjusted in the field. The following section describes methods for determining and setting proper compensation when operating in Controlled-Current mode.

5.2.3 Controlling Compensation for CC Operation

AE Techron 7548/7794/7796/7796HC amplifiers can be configured for either Controlled Voltage

(CV) or Controlled Current (CC) mode of operation. When operating the amplifier in Controlled Voltage (CV) mode, compensation is not required. However, when operating in Controlled Current (CC) mode, the amplifier load becomes an integral part of the system. In order to ensure system stability and to control available bandwidth, compensation via an RC network is required for CC operation. The following steps will allow you to compensate your amplifier for operation in CC mode safely and effectively.

STEP 1: Check Amplifier Operation in CV mode.

We recommend that you power-up and enable the amplifier in Controlled Voltage mode without attaching a load before configuring your amplifier for Controlled Current operation. This will allow you to verify that the input signal and the amplifier are operating correctly.

Once this initial check is completed, power down the amplifier and access DIP switch #1 on the amplifier main board to place the amplifier in CC mode. (Refer to the **Advanced Configuration** section for more information.)

One of two compensation settings can be selected via DIP switch #2 on the main board: CC1 which

enables the factory-installed RC network (see **Figure 5.11**), or CC2 which allows installation of a custom RC network.

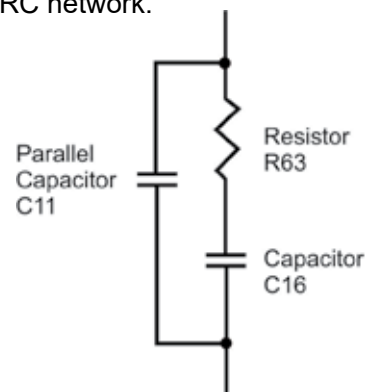

Figure 5.11 – Factory-installed Default RC Network

STEP 2: Determine Required Compensation.

When operating an amplifier in Controlled Current mode, the load becomes an integral part of the system. In order to determine the required compensation for your load, begin by consulting the following table to determine the approximate

compensation capacitance (C) required based on the inductance of your load: Note that these calculations are based on empirical measurements and are approximate.

	Load Inductance (L)		
	<200 μ H	<>200 μ H – <1 mH	>1 mH
Compensation Capacitance (CC)	0.001 μ F	0.01 μ F	0.1 μ F

NOTE: Load Resistance (R) is assumed to be <5 ohms.

STEP 3: Determine if Default or Custom Compensation is Required.

If your load inductance is between 200 microHenries and 1 milliHenry, and your load resistance is less than 5 ohms, then you can likely use the default compensation provided by the amplifier's factory-installed RC network. To select the factory-default compensation, please see **STEP 4** below.

If your load inductance falls outside of the mid-range, or if your load resistance is greater than 5 ohms, then you must calculate your required compensation. If, after calculating your required compensation, you determine that the default compensation will be insufficient for your load, then you will need to enable and install a custom RC network. See **STEP 6** below.

STEP 4: (Optional) Verify Suitability of Default Compensation (CC1)

If desired, the following values of the components contained in the default RC network can be used with the formulas provided in **STEP 5** below to verify the suitability of the default compensation for your uses.

Compensation Resistor: 68.1k ohms

Compensation Capacitor: 47 nF

Parallel Capacitor: 100 pF

STEP 5: Calculating Values for an RC Network for Custom Compensation

If the default RC network does not provide suitable compensation for your intended load, you will need to install a custom RC network that is matched to your load. This network will require two components (a resistor (R) and a capacitor (C)) to be installed on the main board. To calculate the approximate values required for each component, use the following formulas.

COMPENSATION FORMULAS:

To find the value for the resistor (Rc) in the RC network:

$R_c = 20,000 \times 3.14 \times L \times BW$ where:

Rc is compensation resistance in ohms.

L is load inductance in henries.

BW is bandwidth in hertz.

To find the value for the capacitor (Cc) in the RC network:

$C_c = L / (R \times R_c)$

where:

Cc is compensation capacitance in farads.

L is load inductance in henries.



R is resistance of load in ohms.

Rc is compensation resistance in ohms.

STEP 6: Installing and Enabling the Custom RC Network

Once an approximate value for Rc and Cc have been computed, these values will need to be evaluated. To do this, you will need to install the custom components on the amplifier's main board and enable the alternate compensation network (CC2).

The main board can be accessed by removing the amplifier top cover. To remove the amplifier top cover, complete the steps detailed in the following section.

	WARNING
Do not attempt to access the Main Board while the amplifier is running. Turn the amplifier off and disconnect the AC Mains before removing the amplifier front panel.	
	CAUTION
After turning the amplifier off, let the unit sit for 3-5 minutes before removing the front panel. This will allow the electrical charge in the Power Supply capacitors to discharge.	

Accessing the Main Board

The amplifier Main Board can be accessed by removing the amplifier front panel.

IMPORTANT: Before removing the Front Panel, make sure the amplifier is turned off for at least 3-5 minutes and the AC mains are disconnected.

Tool Required

Torx T15 driver

Procedure

1. Turn the power to the amplifier “OFF”.
2. Remove the four hex-head screws, located along the left and right edges of the amplifier front panel using a Torx T15 driver.
3. Remove the front cover by pulling straight towards you.

Custom Compensation Network Installation

When the 7548/7794/7796/7796HC amplifier is used in Controlled-Current mode, the current control loop is tuned with an RC network. The factory default network (CC1) provides 68.1k ohm resistance and 47 nF capacitance. If this default network is not adequate for your application and load, CC2 can be used to install a custom RC network on the amplifier main board.

First, install components with the required values in the main board at locations **R5** and **C2** as shown in **Figure 5.12**.

To change the compensation network, locate **Compensation (CC1/CC2) DIP switch (SW#2)** on the main board. Move the switch to the **Down** position to enable the path to the custom network (CC2).

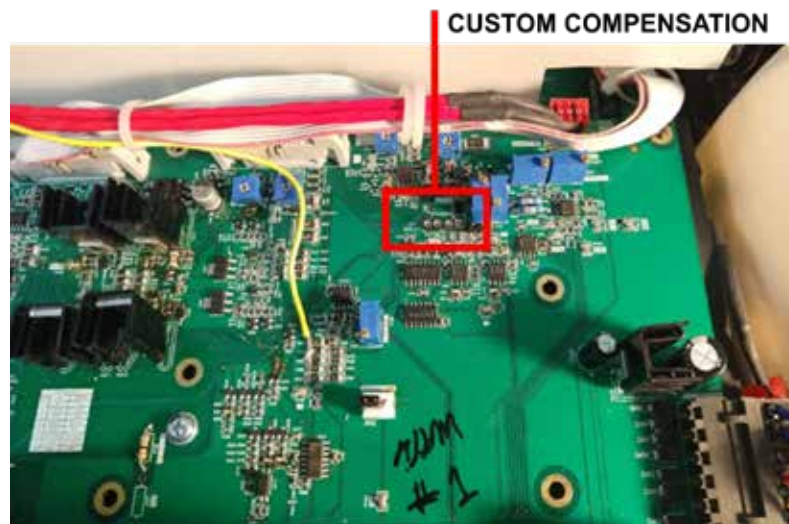

Figure 5.12 – Custom Compensation Component Locations

STEP 7: Optimizing the Compensation Values

Remember the load you are connecting is a part of the system and the amplifier should not be turned on without the load being connected.

After installing the components, check to ensure that the Operation DIP switch (SW#1) is set to Current mode, then power up the amplifier without signal input.

To begin testing, input a square wave with a frequency of 100 Hz to 1 kHz, or a squared pulse at a low level (typically 0.25 to 2.0 volts). A limited-rise-time, repetitive pulse of low duty cycle is preferred.

Observe the output current through a current monitor or current probe. Look for clean transition edges. The presence of ringing or rounding on the transition edges indicates compensation problems. (See **Figure 5.13.**)

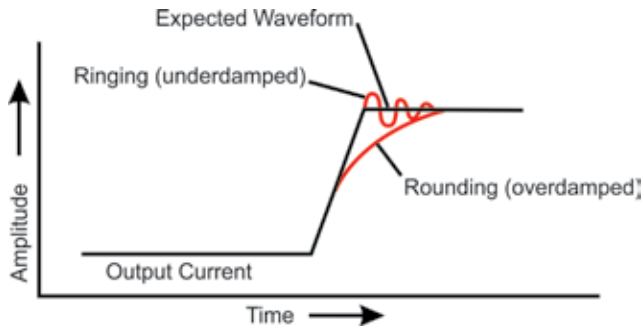

Figure 5.13 – Compensation Effects on Waveform

If a change in compensation is necessary, an adjustment to the resistor component of the Compensation circuit is probably required.

If the output current waveform is ringing, the circuit is underdamped: You have too much gain and should lower the resistance (see **Figure 5.14.**)

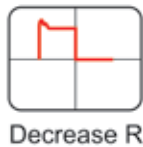

Figure 5.14 – Square Wave Showing a Decrease in R is Required

If the output current waveform is rounded, the circuit is overdamped: You have too little gain and

should increase resistance (see **Figure 5.15.**)

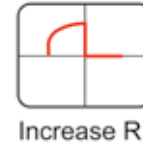

Figure 5.15 – Square Wave Showing an Increase in R is Required

If the output current waveform is neither underdamped or overdamped, but the top of the square-wave is not level, then you should instead increase the capacitor value (see **Figure 5.16.**)

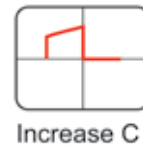

Figure 5.16 – Square Wave Showing an Increase in C is Required

When making adjustments:

Resistor: Increase or decrease resistance values in increments of +/- 10%.

Capacitor: Incrementally increase capacitor values by a factor of 2 or 3.

After final adjustments have been made to the circuit, the final waveform for your planned application should be tested to confirm the amplifier's compensation setting.

NOTE:

- If possible, use 1% metal film resistors. AE Techron discourages installation of potentiometers in the resistor location of the compensation circuit because this can decrease stability and may increase inductance.
- The parallel capacitor in the RC network serves to increase stability but can be removed, if it is not required for system stability. If the parallel capacitor is used, it will usually decrease the value of resistance needed.
- In multiple amplifier systems, expect to decrease the value of R63 in series systems by 1/2.

5.3 Multi-amplifier Systems

The 7548, 7794, 7796 or 7796HC amplifier may be used with other same-model amplifiers to increase voltage or current. Because the internal circuitry of the amplifier is not connected to chassis ground, these amplifiers are well suited for use in series or parallel with other amplifiers of the same model.

Multi-amplifier configurations include: Push/Pull, Series, or Parallel. Two 7548/7794/7796/7796HC amplifiers can be wired in a Push/Pull configuration for approximately double the output voltage. Up to three 7548/7794/7796/7796HC amplifiers may be configured in series for up to three times the continuous output voltage. Up to four 7548/7794/7796/7796HC amplifiers may be configured in parallel for up to four times the continuous current output. See **Figure 5.17** for the approximate output levels you can expect from each multi-amp system.

While it is possible to operate a multi-amp system in either Controlled Voltage or Controlled Current modes of operation, multi-amp operation in Controlled Current mode requires additional configuration of the equipment. Please contact **AE Techron Tech Support** for assistance with configuring a multi-amp system for Controlled Current operation.

Configurations with more amplifiers in series or parallel, and combination series/parallel systems may be possible, depending on the application. For more information on these complex multi-amp systems or for assistance in determining the best multi-amp configuration to meet your requirements, please contact **AE Techron Application Support**.

5.3.1 Multiamp Safety Principles

Following these basic principles will help to ensure the safety of your equipment and personnel.

Use Only Amplifiers of the Same Version

Use only AE Techron amplifiers of the same version to construct a multiamp system. Do not combine different versions or models of AE Techron amplifiers in the same system or use amplifiers made by another manufacturer in an AE Techron multiamp system. Such improper connections could damage the amplifiers.

Use Correct Wiring

Never directly connect one amplifier's OUTPUT terminal to another amplifier's OUTPUT terminal. The resulting circulating currents will waste power and may damage the amplifiers. Depending on the configuration to be used, the OUTPUT terminal of

CONFIGURATION	CONTINUOUS OUTPUT (100% Duty Cycle)	CONFIGURATION	CONTINUOUS OUTPUT (100% Duty Cycle)
7548 Push/Pull	400 Vp	7796 Push/Pull	362 Vp
7548 Two in Series	400 Vp	7796 Two in Series	362 Vp
7548 Three in Series	600 Vp	7796 Three in Series	543 Vp
7548 Two in Parallel	86 Ap	7796 Two in Parallel	254 Ap
7548 Three in Parallel	129 Ap	7796 Three in Parallel	381 Ap
7548 Four in Parallel	172 Ap	7796 Four in Parallel	508 Ap
7794 Push/Pull	196 Vp	7796HC Push/Pull	158 Vp
7794 Two in Series	196 Vp	7796HC Two in Series	158 Vp
7794 Three in Series	294 Vp	7796HC Three in Series	237 Vp
7794 Two in Parallel	382 Ap	7796HC Two in Parallel	278 Ap
7794 Three in Parallel	573 Ap	7796HC Three in Parallel	407 Ap
7794 Four in Parallel	762 AP	7796HC Four in Parallel	556 AP

Figure 5.17 – Typical Output Levels for 7548, 7794, 7796, and 7796HC Multiamp Systems

one amplifier should only be directly connected to the next amplifier's COM terminal or to the load.

Operate with Safety in Mind

Potentially lethal voltages and currents are present within the amplifiers. While the amplifiers' chassis are earth-grounded, **all internal grounds are floating**. Particularly in series systems, all internal grounds of **Follower amplifiers could carry lethal voltages**.

5.3.2 Configuration and Wiring for Push/Pull Operation

Note: Push/Pull configurations can only be used with loads that are NOT ground-referenced.

Accessories Required

For routine, Controlled-Voltage applications, Push/Pull amplifier systems can be configured using two standard 7548, 7794, 7796, or 7796HC amplifiers and the following accessory available from AE Techron:

**Push/Pull DB25 Cable
(part number 69-8005951)**

Please contact AE Techron's **Sales Department** for more information.

Amplifier Labeling

To configure and connect two amplifiers for operation in a push/pull configuration, begin by designating one amplifier as the Master amplifier, and the other amplifier as the Follower amplifier. Consider placing a "Master" or "Follower" label on each amplifier's back panel to clarify the amplifier designation during setup and operation.

Make sure both amplifiers are disconnected from AC power.

Accessing DIP Switches

The DIP switches are located on the amplifier Main Board, which can be accessed by removing the amplifier front panel. See **Figure 4.1** for DIP switches location on the main board.

WARNING

Do not attempt to access the Main Board while the amplifier is running. Turn the amplifier off and disconnect the AC Mains before removing the amplifier front panel.

CAUTION

After turning the amplifier off, let the unit sit for 3-5 minutes before removing the front panel. This will allow the electrical charge in the Power Supply capacitors to discharge.

IMPORTANT: Before removing the Front Panel, make sure the amplifier is turned off for at least 3-5 minutes and the AC mains are disconnected.

Tool Required

Torx T15 driver

Procedure

1. Turn the power to the amplifier "OFF".
2. Remove the four hex-head screws, located along the left and right edges of the amplifier front panel using a Torx T15 driver.
3. Remove the front cover by pulling straight towards you.

Required DIP Switch Settings

DIP switch settings required for Push/Pull operation are shown in **red** in **Figure 5.18**. Configure these DIP switches for both Master and Follower amplifiers.

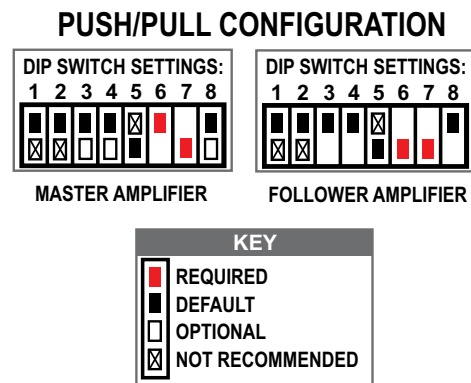

Figure 5.18 – DIP Switch Settings for Push/Pull Configuration

Optional DIP Switch Settings

DIP switches 3, 4 and 8 control amplifier functions that can be optionally enabled for use during multi-amp operation. The Master amplifier controls these functions for the multi-amp system, so you only need to adjust these settings on the Master amplifier.

SW#3 - Low-Pass Filter (50 kHz): Set DIP switch #3 on the Master amplifier in the DOWN position to enable.

SW#4 - Gain (20 / 6): Set DIP switch #4 on the Master amplifier in the DOWN position to change the system gain to 6.

SW#8 - DC/AC Coupling: Set DIP switch #8 on the Master amplifier in the DOWN position to block DC signals.

Build Output Cables

Using wiring appropriate for your application, load and expected output, build three output cables:

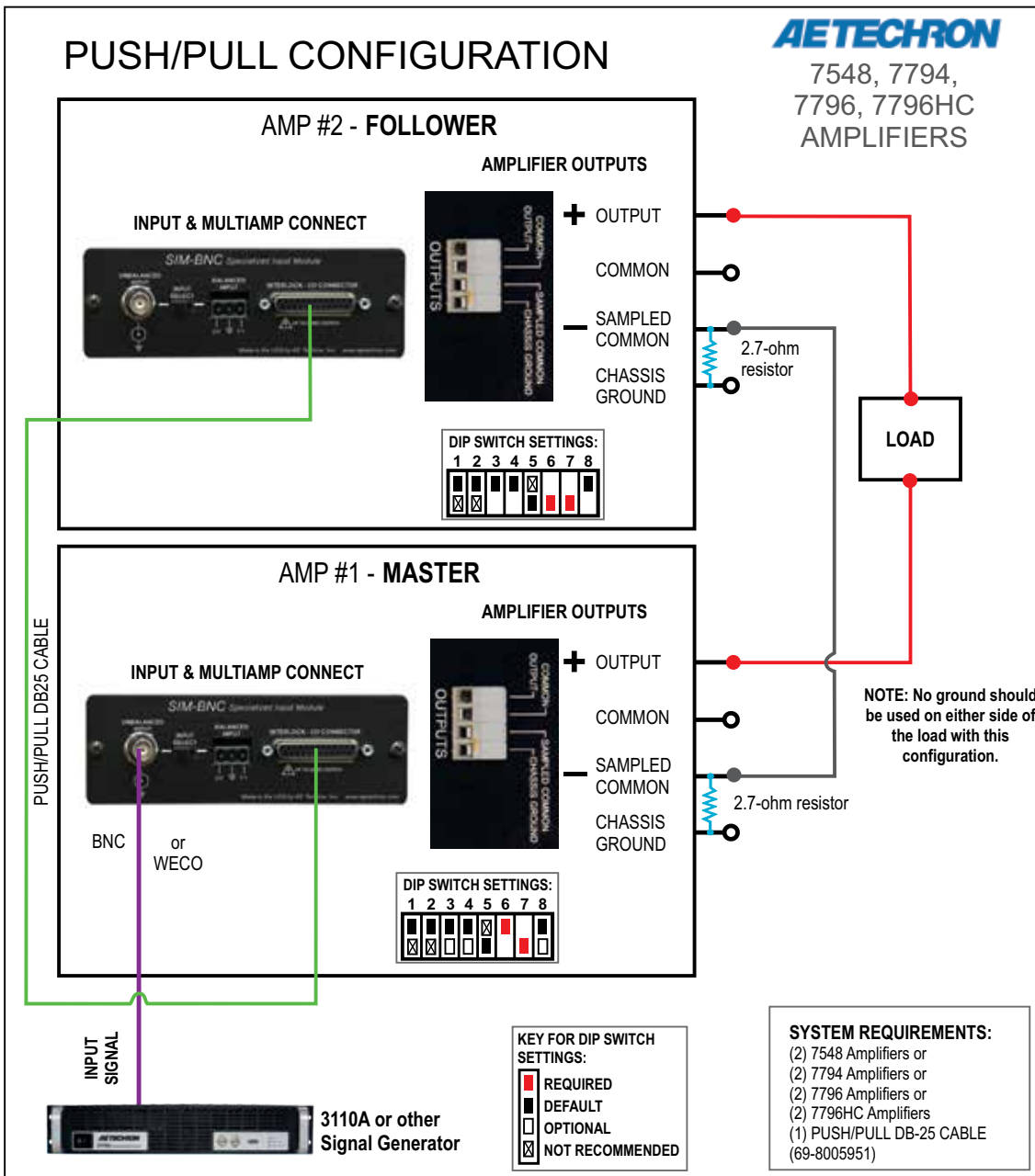
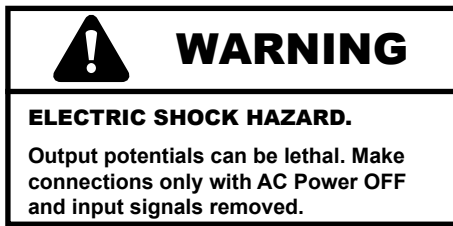

Figure 5.19 – System Configuration for Push-Pull Multi-amp Operation

Two cables to connect from the amplifier's OUTPUT connectors to the load, and one cable to connect (bridge) the two amplifier's COM output connectors.



Amplifier Wiring

Refer to **Figure 5.19** and make the following connections to the Master and Follower amplifiers.

1. Using the DB25 Push/Pull cable, connect from the 25-pin Interlock I/O connector on the SIM-BNC input card of the Master amplifier to the Interlock I/O connector on the SIM-BNC input card of the Follower amplifier.
2. Connect from a signal generator to the BNC or WECO signal input connector on the Master amplifier's back panel SIM-BNC input card.
3. Using the "bridge" output cable, connect from the Master amplifier's back-panel output connector labeled COM to the Follower amplifier's COM connector.
4. On the Master amplifier, connect one output cable to the back-panel output connector labeled OUTPUT and the other end to one terminal your load.
5. On the Follower amplifier, connect the other output cable to the back-panel output connector labeled OUTPUT, then connect the other end to the other terminal on your load.
6. Power up both amplifiers and allow them to come to the Ready state.
7. Apply a sine wave of 5 Vrms at 100 Hz at the Master amplifier input. Using a voltmeter, measure across the system load to verify an output from the system of approximately 200 Vrms.
8. Turn input signal up to the level required for your application.
9. Power down the amplifiers and wait 3-5 minutes to allow the system to discharge.
10. Using wiring appropriate for your application,

connect from the Master amplifier's back-panel SAMPLED COMMON connector to the Follower amplifier's back-panel SAMPLED COMMON connector.

11. Using wiring appropriate for your application and your load, connect from the Master and Follower amplifiers' OUTPUT connectors to the load.
12. Power up your system and confirm the expected system output.

5.3.3 Configuration and Wiring for Parallel Operation

Note: All amplifiers in a Parallel system should be configured as Master amplifiers.

Accessories Required

For routine, Controlled-Voltage applications, Parallel amplifier systems can be configured using up to four standard 7548/7794/7796/7796HC amplifiers and the following accessories available from AE Techron:

- 7700 Series Parallel Wiring Kit (2-amp) (part number 69-8002472)**
- 7700 Series Parallel Wiring Kit (3-amp) (part number 69-8002473)**
- 7700 Series Parallel Wiring Kit (4-amp) (part number 69-8002474)**

Please contact AE Techron's **Sales Department** for more information.

Amplifier Labeling

In a parallel multi-amp system using up to four 7548/7794/7796/7796HC amplifiers, all amplifiers in the system will be configured as Master amplifiers and a parallel input signal will be send to all of the amplifiers. You may wish to label each amplifier numerically (Amplifier #1, Amplifier #2, etc.) for easy reference on inputs and outputs.

Make sure all amplifiers are disconnected from AC power before configuring the amplifiers.

Accessing DIP Switches

The DIP switches are located on the amplifier Main Board, which can be accessed by removing

the amplifier front panel. See **Figure 4.1** for DIP switches location on the main board.

WARNING

Do not attempt to access the Main Board while the amplifier is running. Turn the amplifier off and disconnect the AC Mains before removing the amplifier front panel.

CAUTION

After turning the amplifier off, let the unit sit for 3-5 minutes before removing the front panel. This will allow the electrical charge in the Power Supply capacitors to discharge.

IMPORTANT: Before removing the Front Panel, make sure the amplifier is turned off for at least 3-5 minutes and the AC mains are disconnected.

Tool Required

Torx T15 driver

Procedure

1. Turn the power to the amplifier “OFF”.
2. Remove the four hex-head screws, located along the left and right edges of the amplifier front panel using a Torx T15 driver.
3. Remove the front cover by pulling straight towards you.

Required DIP Switch Settings

DIP switch settings required for Parallel operation are shown in **red** in **Figure 5.20**. Configure these back-panel DIP switches the same for all amplifiers in the system.

PARALLEL CONFIGURATION

DIP SWITCH SETTINGS:

1	2	3	4	5	6	7	8

MASTER AMPLIFIERS
(ALL AMPLIFIERS)

KEY

	REQUIRED
	DEFAULT
	OPTIONAL
<div style="position: absolute; top: 2px; left: 2px; width: 5px; height: 5px; background-color: black;"></div>	NOT RECOMMENDED

Figure 5.20 – DIP Switch Settings for Parallel Configuration

Optional DIP Switch Settings

DIP switches 3, 4 and 8 control amplifier functions that can be optionally enabled for use during multi-amp operation. Be sure to configure any optional settings the same for all amplifiers in the system.

SW#3 - Low-Pass Filter (50 kHz): Set DIP switch #3 on all amplifiers in the DOWN position to enable.

SW#4 - Gain (20 / 6): Set DIP switch #4 on all amplifiers in the DOWN position to change the system gain to 6.

SW#8 - DC/AC Coupling: Set DIP switch #8 on all amplifiers in the DOWN position to block DC signals.

Parallel System Balancing

Before operating a paralleled amplifier system, the system first must be “balanced” to ensure system stability. The balancing process is performed using trim pots located on the amplifier main boards.

The balancing process seeks to calibrate the amplifiers so they operate as similarly as possible. To prevent unwanted current and dissipation in the amplifiers, each amplifier must have as little offset DC as possible at no signal. In addition, the gains of the amplifiers must be as closely matched as possible to keep the outputs from driving each other when a signal is present.

Connect for Balancing

1. For each amplifier in your system, connect a leg of the black output cable found in the Parallel Wiring Kit to one of the amplifier’s output connectors labeled SAMPLED COMMON on the amplifier back panel. Important: Do not connect this cable to the LOAD and do not connect the red cable at this time.
2. Starting with either end of the DB-25 Interlock cable found in the Parallel Wiring Kit, connect the DB-25 connector to the INTERLOCK – I/O CONNECTOR on the SIM-BNC input card of the first amplifier in your system. Connect additional connectors on the DB-25 cable to

the INTERLOCK – I/O CONNECTOR on the SIM-BNC input card of additional amplifiers in your system.

3. Ensure that the inputs of all of the amplifiers are terminated by using a resistor-terminated barrier block connector (see **Figure 5.21**) or similar device.



Figure 5.21 – Terminating the Amplifier Input

Verify Interlock Operation

1. Power up each amplifier by switching to ON the back-panel AC Mains Switch/Circuit Breaker to the ON (up) position. Allow each amplifier to power up and come to Ready state. When Ready, the amplifier Ready and Run LEDs will be lit. Note: Some amplifiers that have been custom configured may require that you press the Enable button to bring the amplifier to the Ready state.
2. On the first amplifier only, press the Stop button to place the amplifier in Standby mode. Verify that all amplifiers in the system enter Standby mode (Standby LED is lit).

Adjust DC Offset

1. Power down all amplifiers. On each amplifier main board, locate the **Offset Adjust** potentiometer (see **Figure 5.22**).
2. Ensure that all amplifier inputs are terminated by using a resistor-terminated barrier block connector (see **Figure 5.21**) or similar device.
3. Power up all amplifiers in the system and run the amplifiers for several minutes in Ready state to allow DC offsets to stabilize.
4. Using a digital voltmeter set to DC, measure across each amplifier's back-panel output

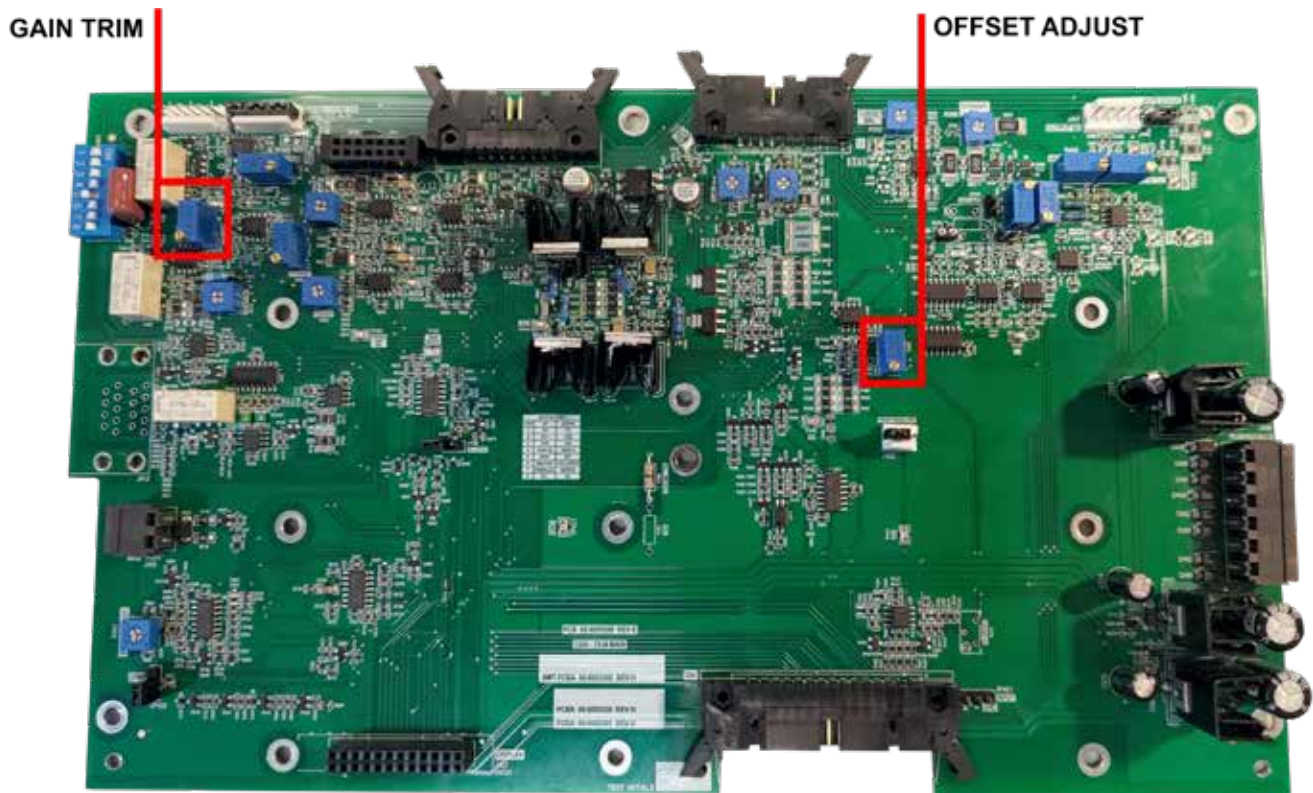

Figure 5.22 – Locations for Balancing Controls on the Main Board

connector terminals (OUTPUT to SAMPLED COMMON) to verify that the DC offset of each amplifier is less than 5 mVdc.

- If the DC offset for any amplifier is greater than 5 mVdc, adjust each amplifier using the **Offset Adjust** potentiometer on the amplifier main board. Adjust each amplifier's DC offset to read as closely as possible to zero

Input Wiring

- Power down the amplifiers.
- Remove all amplifier input terminations.
- Use the wires included in the Parallel Wiring Kit and the Removable Barrier Block connectors that ship with each amplifier to create a paralleled input signal wire as shown in **Figure 5.23**. Wire one input connector for each amplifier in your system. You can use balanced wiring (shown), or you can build the wire for unbalanced input. If using unbalanced wiring, switch the INPUT SELECT switch located on the SIM-BNC input card on each amplifier to the LEFT position (unbalanced setting).
- Alternately, you can connect an unbalanced input signal to the SIM-BNC's BNC input connector using the BNC parallel input wiring as shown in **Figure 5.24**. Set the INPUT SELECT switch located on the SIM-BNC input card on each amplifier to the LEFT position (unbalanced setting). Connect the input wire to a signal generator and to each amplifier in your system.

Verify and Adjust Amplifier Gain

- On the main board of each amplifier, locate the Gain Trim potentiometer (see **Figure 5.22**).
- Connect a digital voltmeter set to AC volts between the OUTPUT and SAMPLED COMMON terminals of the first amplifier.
- Power up the first amplifier. Apply a sine wave to the amplifier input of approximately 5Vrms (100-500 Hz). This should result in about 100Vrms output from the amplifier (assuming a fixed gain of 20).
- If the voltmeter indicates an output greater or lesser than 100 Vrms, adjust the Gain Trim potentiometer to correct.

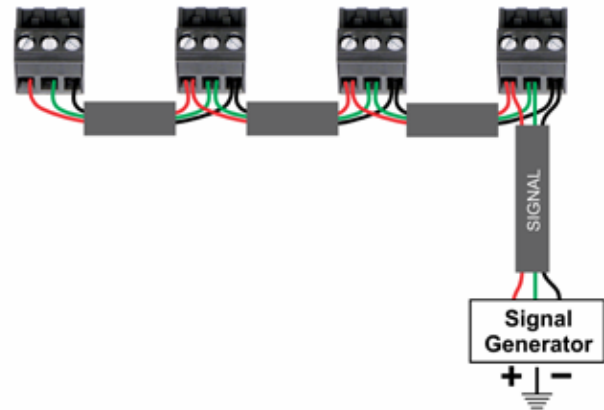

Figure 5.23– Parallel Balanced Input Wiring Using Removable Barrier Block Connectors (Four in Parallel Shown)

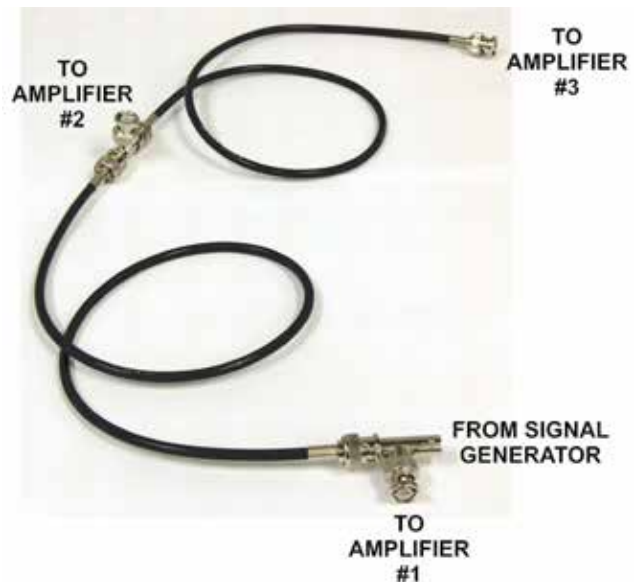

Figure 5.24– Parallel Unbalanced Input Wiring Using BNC Wiring and Connectors (Three in Parallel Shown)

- Power up and repeat this procedure for the second amplifier and all other amplifiers in your system.

Amplifier Gain Matching

- Connect a digital voltmeter set to AC volts between the positive outputs of the first and the second amplifier.
- Adjust the Gain Trim potentiometer on the second amplifier for minimum AC voltage (millivolts).
- Repeat the process of checking gain between

the first amplifier and any additional amplifiers in your system.

4. Continue checking and adjusting until the gain of all amplifiers in the system is matching to within millivolts.

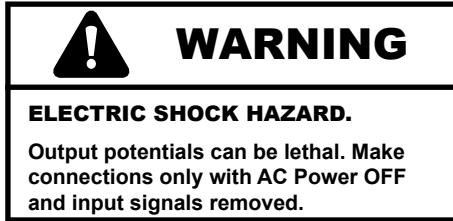

Verify Minimal Circulating Currents

1. Power down the amplifiers.
2. On each amplifier, connect one end of your RED output cable to the positive output terminal (labeled OUTPUT) on each amplifier back panel. **Note: Do not connect the LOAD at this time.**
3. Using a digital voltmeter set to AC volts, connect between the positive outputs of the first and second amplifier (OUTPUT to OUTPUT).
4. Starting with an input level of 0.5 Vrms, verify a meter reading of less than 50 mV. (50 mV corresponds to 0.5A of circulating current.)
5. Check any additional amplifiers in your system.
6. Continue to monitor the DVM readings while turning signal input level up to the level required for your application.

Verify Current Sharing

1. Power down the amplifiers.
2. Connect your load to the two output cables. Connect the positive terminal of your load to the red cable connected to the amplifier OUTPUT terminals. Connect the negative terminal of your load to the black cable connected to the amplifier SAMPLED COMMON terminals.
3. Check to ensure that all system wiring has been correctly installed as shown in **Figure 5.25**.
4. Starting with a signal input approximately 10% of the typical input required for your application, power up the amplifiers.
5. Using a digital voltmeter set to AC volts, connect between the positive outputs of the

amplifiers (Amplifier #1 OUTPUT to Amplifier #2 OUTPUT). Verify a meter reading of less than 200 mV, up to the typical power level for the application. (200 mV corresponds to 2A of circulating current.) Check additional amplifiers in your system.

6. Continue to monitor the DVM readings while turning signal input level up to the level required for your application.

5.3.4 Configuration and Wiring for Series Operation

Note: A maximum of three amplifiers can be configured for series operation in a multi-amp system.

Accessories Required

For routine, Controlled-Voltage applications, Series amplifier systems can be configured using up to three standard 7548/7794/7796/7796HC amplifiers and the following accessories available from AE Techron:

SIM-BNC-OPTOC Input Card (part number 69-1875020). Requires one card for each amplifier in the system.

DB9M Series Cable (part number 69-8002516). One cable required for two-amplifier systems. Two cables required for three-amplifier systems.

Please contact AE Techron's **Sales Department** for more information.

Amplifier Labeling

To configure and connect up to three amplifiers for operation in a series configuration, begin by designating one amplifier as the Master amplifier. Up to three 7548/7794/7796/7796HC amplifiers can be configured for series operation, so all other amplifiers in the system will operate as Follower amplifiers. Consider placing labels on each amplifier's back panel to clarify the amplifier designation during setup and operation (Master, Follower #1, Follower #2).

Make sure all amplifiers are disconnected from AC power.

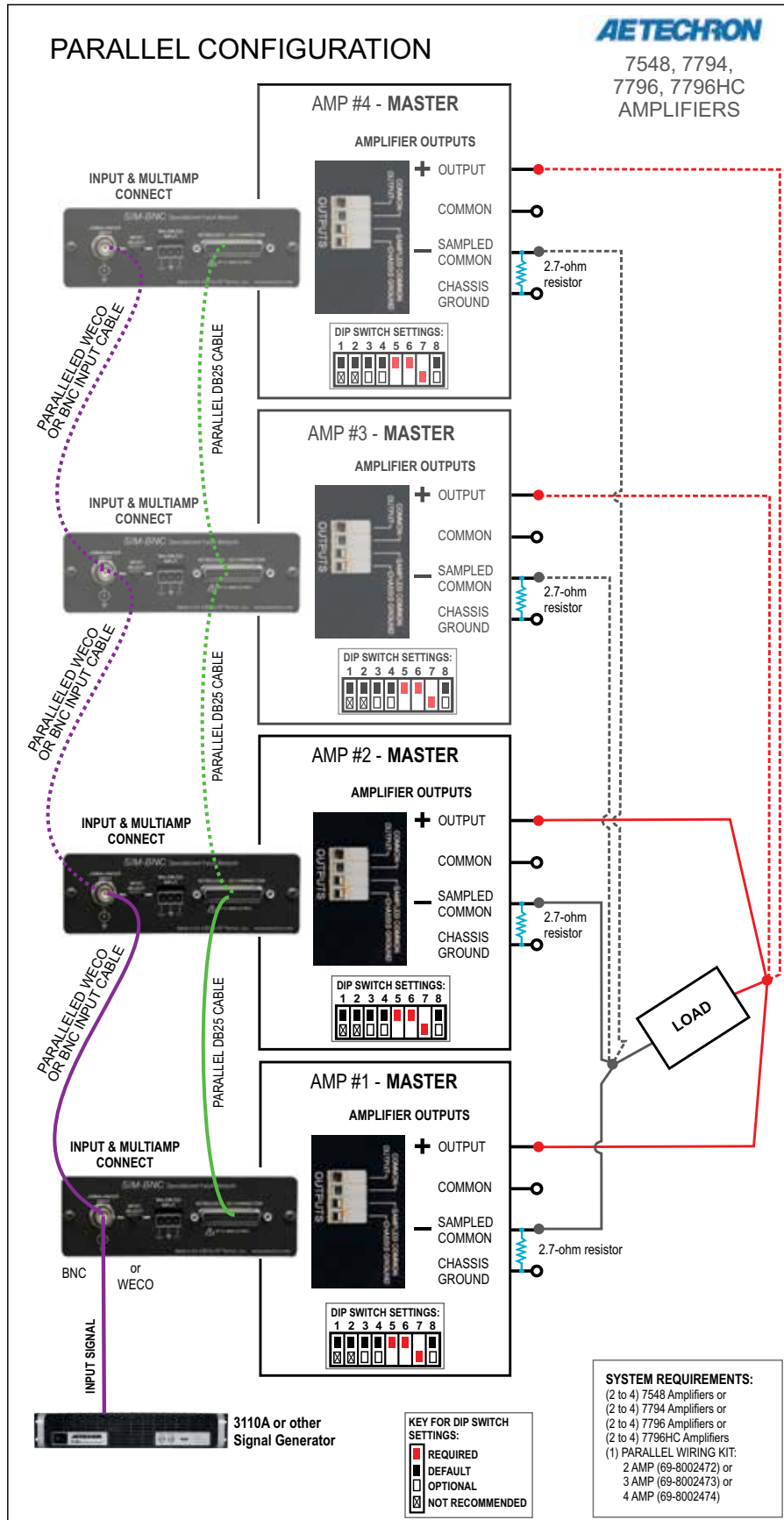

Figure 5.25 – System Configuration for Parallel Multi-amp Operation

Required DIP Switch Settings

DIP switch settings required for Series operation are shown in **red** in **Figure 5.26**. Configure these back-panel DIP switches for the Master and all Follower amplifiers.

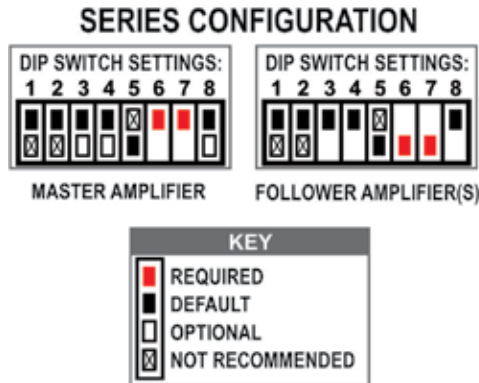

Figure 5.26 – DIP Switch Settings for Series Configuration

Optional DIP Switch Settings

DIP switches 3, 4 and 8 control amplifier functions that can be optionally enabled for use during multi-amp operation. The Master amplifier controls these functions for the multi-amp system, so you only need to adjust these settings on the Master amplifier.

SW#3 - Low-Pass Filter (50 kHz): Set DIP switch #3 on the Master amplifier in the DOWN position to enable.

SW#4 - Gain (20 / 6): Set DIP switch #4 on the Master amplifier in the DOWN position to change the system gain to 6..

SW#8 - DC/AC Coupling: Set DIP switch #8 on the Master amplifier in the DOWN position to block DC signals.

Configure SIM-BNC-OPTOC cards

Each amplifier in a 7548/7794/7796/7796HC Series multi-amp system uses a specialized input card (SIM-BNC-OPTOC) that helps to synchronize the operation of all amps in the system and provides for optical isolation. The input card allows you to designate (via jumpers located on the card), that the input card will function as a Master or a Follower.

If desired, you can also configure the WECO input connector on the SIM-BNC-OPTOC card to be used as an unbalanced input via jumpers located on the input card.

Jumper locations for the SIM-BNC-OPTOC card are shown in **Figure 5.27**.

Jumpers 4 & 5: When J4 and J5 are Closed, the input card is configured to function in an amplifier that will act as a Single amplifier, or as a Master amplifier in a multi-amplifier system. When J4 and J5 are Open, the input card is configured to function in an amplifier that will act as a Follower in a multi-amplifier system. **Factory default:** Closed.

Jumper Configuration: For all except one SIM-BNC OPTOC input cards, remove the shunts from Jumpers 4 and 5 to configure the cards to function

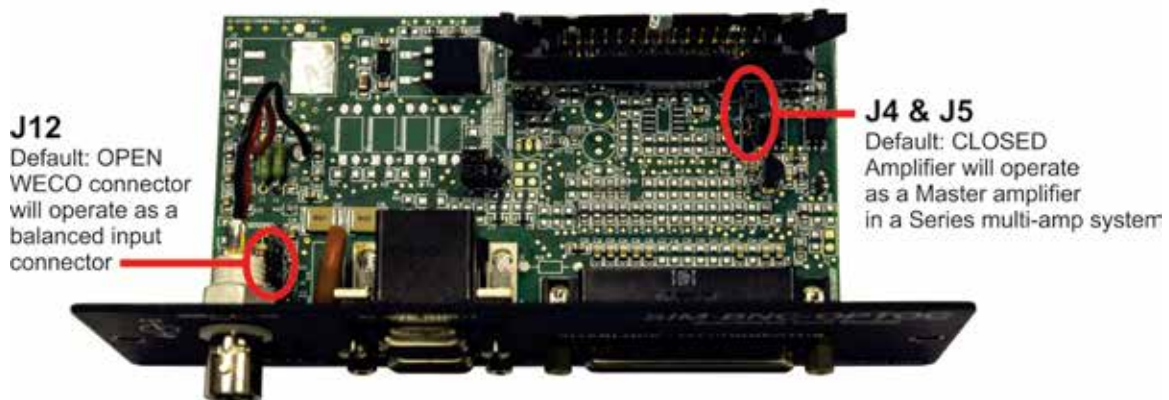

Figure 5.27 – SIM-BNC-OPTOC jumper locations

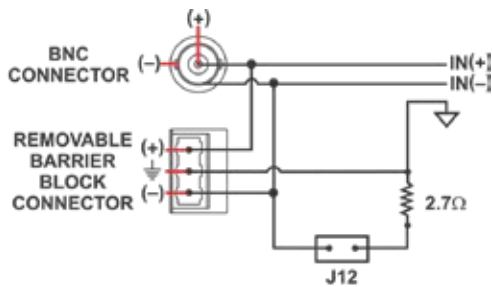

Figure 5.28 – SIM-BNC-OPTOC input connectors' internal wiring

as Followers. Place a label reading “Master” or “Follower” on the front of each input card to clarify the function of each card.

Jumper J12: When Open, this option lifts the negative (–) leg from ground on both input connectors, allowing the WECO connector to be used as a balanced input and the BNC connector to be used as an unbalanced floating input. When Closed, the negative (–) leg is tied to ground through a 2.7-ohm resistor, allowing either the BNC or the Removable Barrier Block connector to be used as an unbalanced grounded input. **Figure 5.28** details the input connectors' internal wiring.

Factory default: Open.

Jumper Configuration: To configure the WECO input to be used as an unbalanced input, place a shunt at Jumper J12 on the Master input card only.

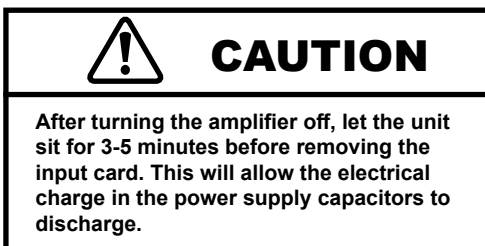

Install SIM-BNC-OPTOC cards in Amplifiers

Before preparing the amplifiers, make sure the amplifier is turned off for at least 3-5 minutes and the AC mains are disconnected.

1. Locate the standard SIM-BNC Input Card on the right side of the rear panel of each amplifier.

2. Use a #2 Phillips screwdriver to remove and retain the two (2) screws located at the edges of the input card.
3. Unplug the ribbon cable from the back of the input card; remove the card from the amplifier card bay.
4. For each amplifier, plug the ribbon cable into the ribbon connector on the SIM-BNC-OPTOC card. Reinstall the card into the card bay on the amplifier back panel and secure in place using the retained screws.

Remove 2.7-ohm Resistors from Follower Outputs

Use a #1 Phillips screwdriver to remove the 2.7-ohm resistor on the amplifier output connectors from all amplifiers that will be operating as Follower amplifiers. See **Figure 5.29**. **IMPORTANT: These resistors must be removed before operating your Series system to avoid potential product failure.**

Retain the resistor for later use.

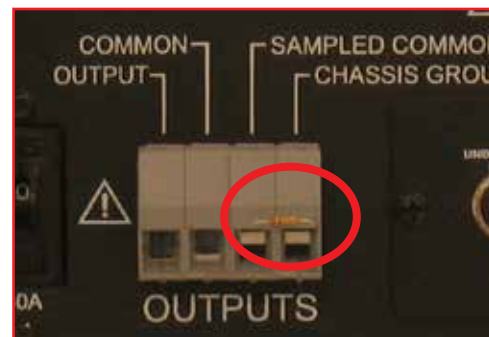

Figure 5.29 – Output Terminal Resistor

Amplifier Wiring

Refer to **Figure 5.30** or **5.31** and make the following connections to the Master and Follower amplifiers.

1. Connect the DB9M Series Cable (part number 69-8004125) from the MASTER OUTPUT connector on the Master amplifier's SIM-BNC-OPTOC card to the SLAVE INPUT connector on the first Follower amplifier's SIM-BNC-OPTOC card.
2. Connect from a signal generator to the BNC or WECO signal input connector on the Master

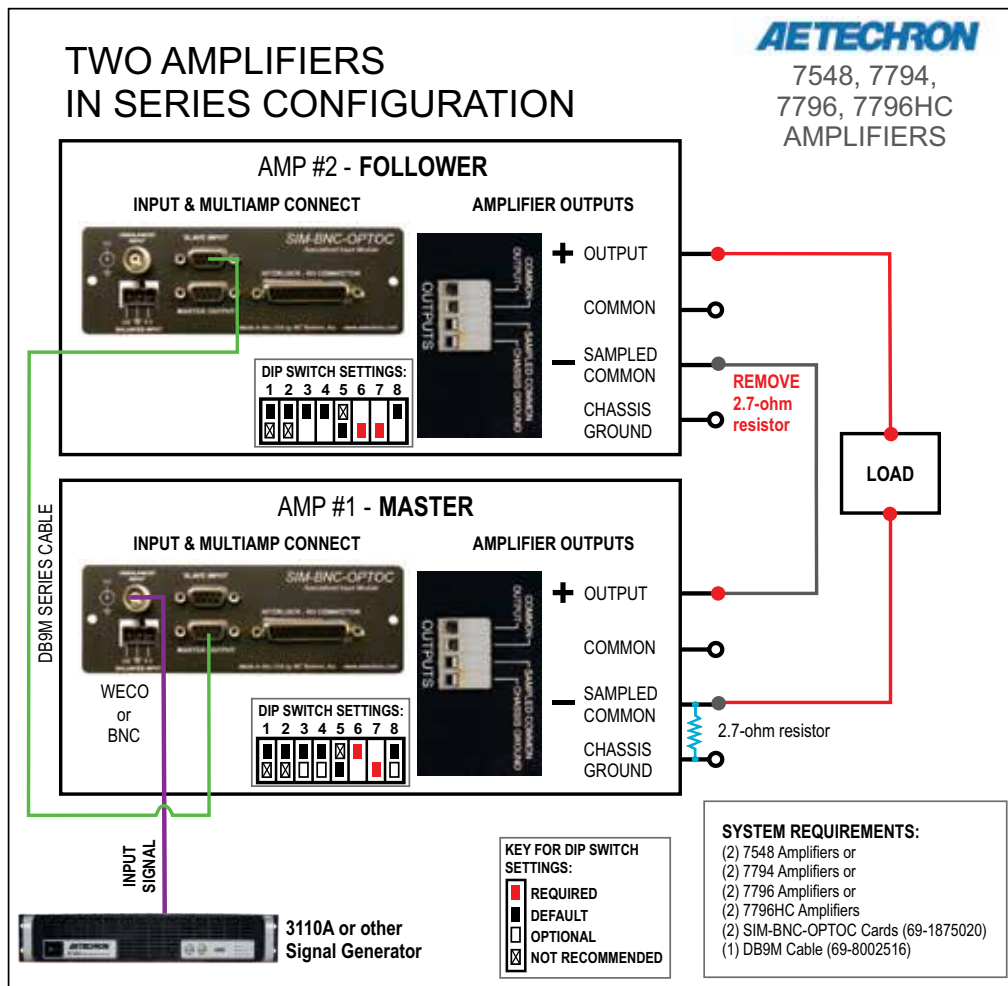

Figure 5.30 – System Configuration for Two in Series Multi-amp Operation

amplifier's back panel SIM-BNC-OPTOC input card.

- Using wiring appropriate for your application, connect from the Master amplifier's back-panel OUTPUT connector to the first Follower amplifier's back-panel SAMPLED COMMON connector.
- For a three amplifier system, connect from the first Follower amplifier's back-panel OUTPUT connector to the second Follower amplifier's back-panel SAMPLED COMMON connector.
- Using wiring appropriate for your application and your load, connect from the first (or second, if a three amplifier system) Follower amplifier's OUTPUT connector to the load's positive terminal.
- Connect from the load's negative terminal to

the Master amplifier's SAMPLED COMMON connector.

5.3.5 Multiamp System Start-up Procedure (All System Types)

- Turn down the level of your signal source.
- Make sure the Gain Control on both amplifiers is turned fully clockwise (100%).
- Depress the POWER switches on both the Master and the Follower amplifiers (in any order) to turn the power ON.
- Wait for the yellow READY and green RUN LEDs to illuminate on both amplifiers.
- Adjust the input signal level to achieve the desired output level.

5.3.6 Multiamp System Operation

In multiamp systems, the Master amplifier controls several operating functions for all amplifiers

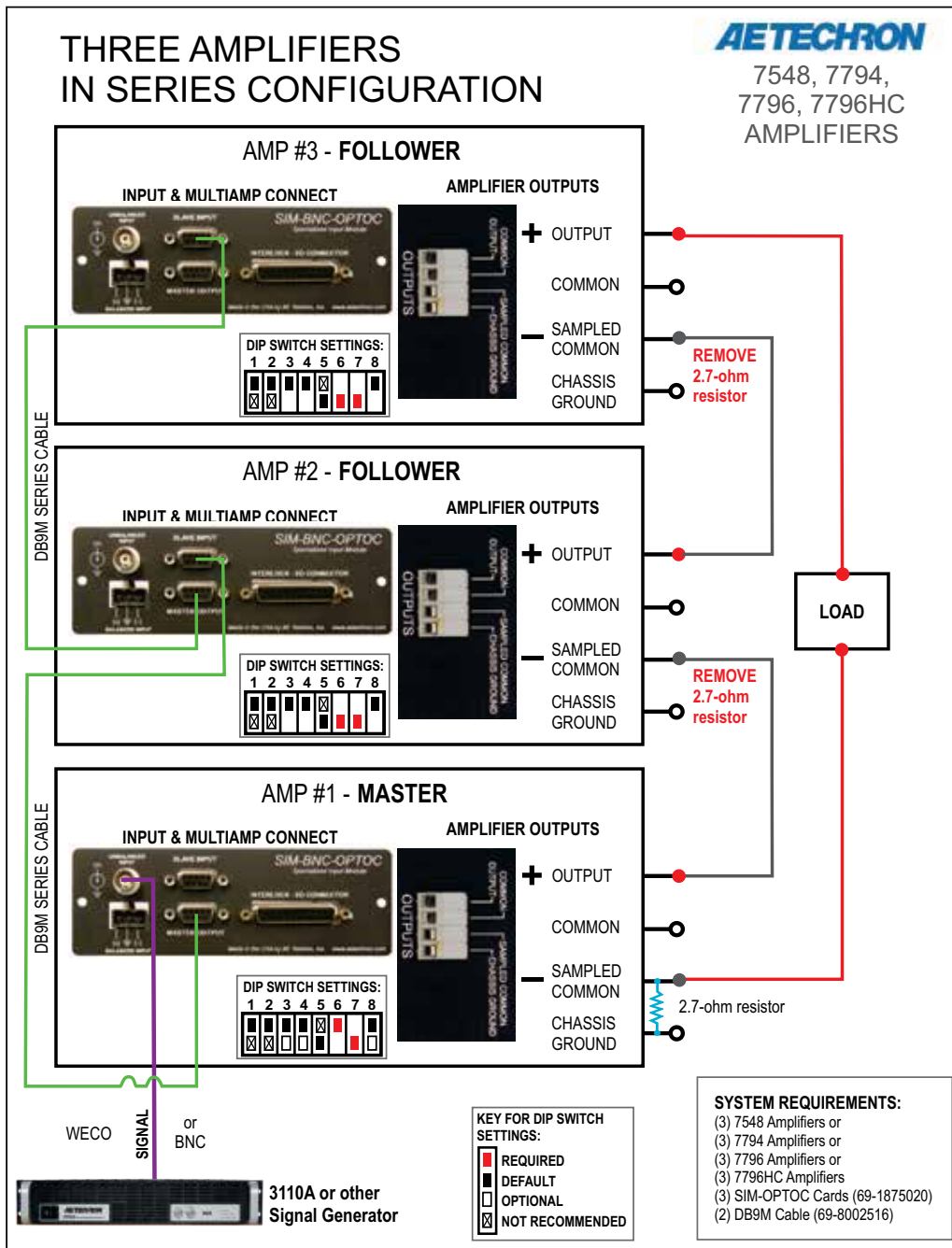

Figure 5.31 – System Configuration for Three in Series Multi-amp Operation

included in the system, so Follower amplifiers are said to be “interlocked” with the Master amplifier. The functions controlled by the Master amplifier include input signal, operating status, low-pass filter, gain, AC/DC coupling, mode of operation (controlled-voltage or controlled-current operation) and amplifier compensation.

Because the amplifiers in a multiamp system are interlocked, the main and fault status indicators of

all amplifiers in the system must be considered to determine the current status and the necessary remedies to return the system to operational status when a fault condition occurs.

Enable, Stop and Reset Buttons

The following details the results when each of the three Push Buttons are pressed on an amplifier front panel in a multi-amp system.

Enable – In multi-amp systems that have been configured to start up in Run mode (factory default setting), when an amplifier is powered on, the amplifier will be placed in Remote Standby mode (Ready and Standby LEDs lit) and remain in Remote Standby mode until all amplifiers in the system have been powered on. The system will automatically proceed to Run mode when all amplifiers in the system are powered on and achieve Remote Standby mode.

In multi-amp systems that have been configured to start up in Stop mode, when an amplifier is powered on, the amplifier will be placed in Standby/Stop mode (Stop and Standby LEDs lit). When the Enable button is pressed on each amplifier, that amplifier will be placed in Remote Standby mode (Ready and Standby LEDs lit) and remain in Remote Standby mode until all amplifiers in the system have been Enabled. The system will automatically proceed to Run mode when all amplifiers in the system achieve Remote Standby mode.

Stop – Pressing the Stop button on any amplifier in the system will place that amplifier in Standby/Stop mode and place all other amplifiers in the system in Remote Standby mode.

Reset – Pressing the Reset button on the amplifier reporting a fault condition will return all of the amplifiers to Run mode if the condition causing the fault condition has been cleared and the amplifier has been configured for startup in Run mode. However, pressing the Reset button on other amplifiers in the system (not reporting a fault condition) will NOT clear the fault condition. Refer to the **“Fault Status Indicators”** section for information on how to clear fault conditions and restore amplifier operation.

If the amplifier reporting the fault condition has been configured for startup in Stop mode, pressing the Reset button will place the amplifier in Standby/Stop mode. Press the Enable button to return the amplifier system to Run mode.

Main Status Indicators for Multi-amplifier Systems

The Main Status indicators on each amplifier in a multi-amp system are used to determine the operational status of the amplifier. When evaluated along with the statuses of other amplifiers in the

system, the Main Status indicators can be used to determine the system status and the action required to return the system to Run mode. See **Figure 5.32**.

Figure 5.32 – Main Status Indicators for Multi-Amplifier Systems

● ● ● Indicator is lit ● Indicator is not lit ○ Indicator may be lit

Main Status of One or More Amps in the System	Main Status of Other Amps in the System	State of Operation	Action Needed to Return to Run Mode
<ul style="list-style-type: none"> ● Run ● Ready ● Standby ● Stop 	<ul style="list-style-type: none"> ● Run ● Ready ● Standby ● Stop 	<p>Run mode: All of the amplifiers in the system are in Run mode. The amplifiers' high-voltage transformers are energized and the system will amplify the input signal.</p>	N/A
<ul style="list-style-type: none"> ● Run ● Ready ● Standby ● Stop 	<ul style="list-style-type: none"> ● Run ● Ready ● Standby ● Stop 	<p>Remote Standby mode: All of the amplifiers in the system are being held in Standby mode by an external condition. In Standby mode, the amplifiers' low-voltage transformers are energized but the high-voltage transformers are not.</p>	<p>If the amplifiers remain in Standby mode, the system is being held in Standby by remote control through one of the Interconnect ports (Version D only) or the SIM Interlock I/O connector. Activate the Standby switch to clear this remote Standby condition and return the system to Run mode. See the topic “Remote Status and Control Using the Interconnect Ports” and “Remote Status and Control Using the Interlock I/O Connector” in the Applications section of this manual for more information on remote amplifier operation.</p>
<ul style="list-style-type: none"> ● Run ● Ready ● Standby ● Stop 	<ul style="list-style-type: none"> ● Run ● Ready ● Standby ● Stop 	<p>System Not Ready: If one or more of the amplifiers has no LEDs lit, the amplifier has no power or has not been turned on, and the other amplifiers in the system will be held in Remote Standby mode. In Remote Standby mode, the amplifier's low-voltage transformer is energized but the high-voltage transformers are not.</p>	<p>Make sure all amplifiers have AC power and have been turned on. When all amplifiers attain Standby status, all amplifiers in the system will simultaneously be placed in Run mode.</p>
<ul style="list-style-type: none"> ● Run ● Ready ● Standby ● Stop 	<ul style="list-style-type: none"> ● Run ● Ready ● Standby ● Stop 	<p>Standby/Stop mode: When the Stop button on any amplifier in the system is pressed, that amplifier will enter Stop mode and all other amplifiers will enter Remote Standby mode. The system may also enter Stop mode after powering up if one or more amplifiers in the system is configured to enter Stop mode on startup. In Stop mode, the amplifier's low-voltage transformer is energized but the high-voltage transformers are not.</p>	<p>To release the system from Standby/Stop mode, press the Enable button on the amplifier displaying the Stop mode status.</p>

Fault Status Indicators for Multi-Amp Systems

The four Fault Status indicators located on each amplifier's front panel are used to monitor the internal conditions of the amplifier and will illuminate when a fault condition occurs. All amplifiers in the system may be placed in Standby mode when a fault condition occurs, depending on the fault con-

dition and the configuration of the system. Typically, the system can be released from Standby mode by pressing the Reset button on the amplifier displaying the Fault status. Refer to the chart in **Figure 5.33** to determine the fault condition being indicated and the action required to clear the fault condition and return the system to Run mode.

Figure 5.33 – Fault Status Indicators for Multi-Amplifier Systems

● ● ● Indicator is lit ● Indicator is not lit ○ Indicator may be lit

One or More Amps in System		Other Amps in System		State of Operation	Action Needed to Clear Fault Condition and Return to Run Mode
Main Status Indicators	Fault Status Indicators	Main Status Indicators	Fault Status Indicators		
<ul style="list-style-type: none"> ● Run ● Ready ● Standby ● Stop 	<ul style="list-style-type: none"> ● Fault ● Over Load ● Over Temp ● Over Voltage 	<ul style="list-style-type: none"> ● Run ● Ready ● Standby ● Stop 	<ul style="list-style-type: none"> ● Fault ● Over Load ● Over Temp ● Over Voltage 	<p>Output Fault status: This indicates that an Output Fault condition has occurred in the amplifier displaying the Fault status, and the system has been placed in Standby mode. The Fault indicator will light under two conditions: 1) High-frequency oscillation is causing high shoot-through current; or 2) An output transistor has shorted, causing the output fault condition.</p>	<p>This fault condition cannot be cleared using the front-panel Reset button. See the “Troubleshooting” section for more information on diagnosing and clearing this fault condition.</p>
<ul style="list-style-type: none"> ● Run ● Ready ○ Standby ● Stop 	<ul style="list-style-type: none"> ● Fault ● Over Load ● Over Temp ● Over Voltage 	<ul style="list-style-type: none"> ● Run ○ Ready ○ Standby ● Stop 	<ul style="list-style-type: none"> ● Fault ● Over Load ● Over Temp ● Over Voltage 	<p>Over Load status: This indicates that the output of the system could not follow the input signal due to voltage or current limits. Under normal operation with the factory-default settings, an Over Load condition will not place the system in Standby mode. If the system has been configured to be forced to Standby on Over Load, the system will be placed in Standby mode when the Over Load indicator lights.</p>	<p>To remedy the Over Load fault during operation, turn down the level of the input signal until the Over Load indicator turns off. To clear an Over Load fault condition when the amplifier is forced to Standby, turn down the level of the input signal, then push the Reset button on the amplifier(s) displaying the Over Load status.</p>

One or More Amps in System		Other Amps in System		State of Operation	Action Needed to Clear Fault Condition and Return to Run Mode
Main Status Indicators	Fault Status Indicators	Main Status Indicators	Fault Status Indicators		
<ul style="list-style-type: none"> ● Run ● Ready ● Standby ● Stop 	<ul style="list-style-type: none"> ● Fault ● Over Load ○ Over Temp ● Over Voltage 	<ul style="list-style-type: none"> ● Run ● Ready ● Standby ● Stop 	<ul style="list-style-type: none"> ● Fault ● Over Load ● Over Temp ● Over Voltage 	<p>Over Temp status: Each amplifier in the system monitors the temperature inside the high-voltage transformers, low-voltage transformer and in the output stage heat sinks. The Over Temp indicator will light and the system will be placed in Standby mode when the temperature sensors detect a condition that would damage the amplifier system. If the Over Temp pulse is extremely short, as in the case of defective wiring or switches, the Over Temp LED may be lit too briefly to observe.</p>	<p>To reset after an Over Temp fault has occurred, make sure the amplifier fans in all amplifiers are running, and then remove the input signal from the system. Allow the fans to run for about 5 minutes, or until the amplifier has sufficiently cooled. Push and hold the Reset button on any amplifier displaying the Over Temp status until the Standby LED turns off, then release the Reset button to return the system to Run mode. Please see the Troubleshooting section for information on correcting the cause of an Over Temp fault condition.</p>
<ul style="list-style-type: none"> ● Run ● Ready ● Standby ● Stop 	<ul style="list-style-type: none"> ● Fault ● Over Load ● Over Temp ● Over Voltage 	<ul style="list-style-type: none"> ● Run ● Ready ● Standby ● Stop 	<ul style="list-style-type: none"> ● Fault ● Over Load ● Over Temp ● Over Voltage 	<p>Over Voltage status: This indicates that the AC mains voltage is more than +10% of nominal. All amplifiers in the system will be forced to Standby when an Over Voltage condition occurs. When the Over Voltage condition is cleared, the system will automatically return to Run mode.</p>	<p>To clear an Over Voltage fault condition, the AC mains must be brought down to the nominal value. If the system does not return to Run mode when the Over Voltage condition has cleared, one or more amplifiers may require servicing. Please see the Troubleshooting section for more information.</p>

6 Maintenance

Simple maintenance can be performed by the user to help keep the equipment operational. The following routine maintenance is designed to prevent problems before they occur. See the **Troubleshooting** section for recommendations for restoring the equipment to operation after an error condition has occurred.

Preventative maintenance is recommended after the first 250 hours of operation, and every three months or 250 hours thereafter. If the equipment environment is dirty or dusty, preventative maintenance should be performed more frequently.

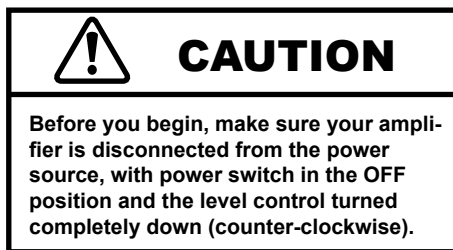

6.1 Clean Amplifier Filter and Grills

6.1.1 Tools Required

The recommended equipment and supplies needed to perform the functions required for this task are described below.

- Torx T15 driver
- Vacuum cleaner
- Damp cloth (use water only or a mild soap diluted in water)

To ensure adequate cooling and maximum efficiency of the internal cooling fans, the amplifier's front and rear grills should be cleaned periodically. To clean the amplifier grills and filter, complete the following steps:

1. Turn the amplifier OFF. Disconnect the amplifier from its power source.
2. Remove the four Torx-head screws, located along the left and right edges of the amplifier's front panel using a Torx T15 driver. Retain.
3. Remove the amplifier's front cover by pulling straight towards you.
4. Using a vacuum cleaner, vacuum the front and rear ventilation grills. Vacuum the filters behind the front ventilation grill.
5. Using a damp cloth, clean the front and rear ventilation grills. Dry with a clean cloth or allow to air dry. **IMPORTANT: Grills should be completely dry before plugging in or restarting amplifier.**

7 Troubleshooting

7.1 Introduction & Precautions

This section provides a set of procedures for identifying and correcting problems with the 7548/7794/7796/7796HC amplifier. Rather than providing an exhaustive and detailed list of troubleshooting specifications, this section aims to provide a set of shortcuts intended to get an inoperative amplifier back in service as quickly as possible.

The procedures outlined in this section are directed toward an experienced electronic technician; it assumes that the technician has knowledge of typical electronic repair and test procedures.

Please be aware that these amplifiers may undergo frequent engineering updates. As a result, modules and electronic assemblies may not be interchangeable between units. Particularly, the Main board undergoes periodic engineering modifications that may make interchangeability between units impossible.

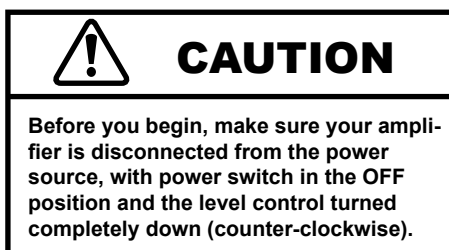

Figure 7.1 – Amplifier cover removed for inspection

7.2 Visual Inspection

Before attempting to troubleshoot the amplifier while it is operating, please take time to complete a visual inspection of the internal components of the amplifier.

1. To perform a Visual Inspection, first turn OFF the power at the rear circuit breaker.
2. Disconnect the AC mains plug from the amplifier.
3. Wait three to five minutes for the Power Supply capacitors to discharge.
4. Remove the 16 single screws from the top cover.
5. Inspect the amplifier's internal components (see **Figure 7.1**). Check the following:
 - Inspect modules for charring, breaks, deformation or other signs of physical damage.
 - Look for any foreign objects lodged inside the unit.
 - Inspect the entire lengths of wires and ribbon cables for breaks or other physical damage.
6. If there is any physical damage to the amplifier, please return it to AE Techron for repair.

7.3 No Signal

Missing Output signal may be caused by one of the following:

1. Master/Follower Jumpers are set to the Follower (down) position. The amplifier should only be configured for Follower mode if it is in a multi-amplifier system; otherwise it should be set for Master mode. See the **Advanced Configuration** section in this manual for more information.
2. Signal is not connected to any inputs on the SIM card. See the **Amplifier Setup** section in this manual for more information.

7.4 No LEDs Illuminated or No Fans

If none of the LEDs on the Display Panel are illuminated and/or the fans are inoperative, check the following:

1. The AC mains are not connected or not on (see the **Amplifier Setup** section for more information).



Figure 7.2 – Fuse F1 Location

2. Back Panel Breaker is not in the UP position.
3. Fuse F1 is open.

To Inspect Fuse F1 follow these steps:

1. Turn Off the amplifier and disconnect the AC mains.
2. Locate Fuse Cover on the amplifier back panel (see **Figure 7.2**). Remove Fuse Cover.
3. Remove fuse and inspect. Replace, if necessary, with 1A slow blow fuse.

7.5 OverVoltage Warning Message

The amplifier will protect itself from AC mains voltage that is 10% above the voltage indicated on the back panel. If the AC mains voltage is more than 10% above the operating voltage, reduce the AC mains voltage to the proper level. When the line voltage condition is corrected, the amplifier will automatically reset. If the amplifier does not automatically reset, the amplifier's three internal transformers may need to be rewired. Please see the Factory Service information at the end of this section.

7.6 Standby LED Remains Illuminated

The Standby indicator may remain illuminated under three conditions:

1. If the output wells or power transformer have overheated. If overheating is the problem, see the following topic (“**Amplifier Overheats**”).
2. If both the Standby and Ready LEDs remain illuminated and the Interlock I/O Cable is being used, the amplifier is being held in Remote Standby mode by another device (see **Figure 7.3**). For more information on Remote Op-

eration, see the **Applications** section in this manual.

3. If the connection to the Interlock – I/O Connector or other input/output connection isn't fully secure. Check all wiring and connections.

7.7 Amplifier Overheats (Over Temp Fault Condition)

There are two possible reasons why the amplifier is overheating:

1. Excessive Power Requirements
2. Inadequate Airflow

7.7.1 Excessive Power Requirements

An amplifier will overheat if the required power exceeds the amplifier's capabilities. High duty cycles and low-impedance loads are especially prone to cause overheating. To see if excess power requirements are causing overheating, check the following:

1. The application's power requirements fall within the specifications of the amplifier. See the **Specifications** section.
2. Faulty output connections and load.



Figure 7.3 – Interlock I/O Connector

- Undesired DC offset at the Output and Input signal.

7.7.2 Check for Inadequate Airflow

If the amplifier chronically overheats with suitable power/load conditions, then the amplifier may not be receiving adequate airflow. To check for adequate airflow, proceed with the following steps:

- Check air filters. Over time they can become dirty and worn out. It is a good idea to clean the air filters periodically with a mild detergent and water.
- Visually inspect fans to assure correct operation while amplifier is On.

Any inoperative, visibly slow, or reverse-spinning fan should be replaced. Please see the Factory Service information at the end of this section.

An OverTemp condition places the amplifier in Standby mode. If the OverTemp pulse is extremely short, as in the case of defective wiring or switches, the OverTemp pulse may be too brief to observe.

7.7.3 Resetting After OverTemp

To reset the amplifier after an OverTemp has occurred, make sure fans are running, then remove the input signal from the amplifier. Allow the fans to run for five minutes, and then push the Reset button to reset the amplifier.

7.8 Fault LED is Illuminated

The 7548/7794/7796/7796HC contains protection circuitry that disables the amplifier if an output stage is behaving abnormally. This usually indicates an output transistor has shorted.

To clear the Fault condition, follow these steps:

- Turn off the signal source.
- Turn off the AC mains.
- Turn AC mains power back on. If the Fault LED doesn't illuminate again, turn the signal source on.

- If the Fault LED is still illuminated and the Fault condition doesn't clear, return the amplifier for Factory Service. Please see the Factory Service information at the end of this section.

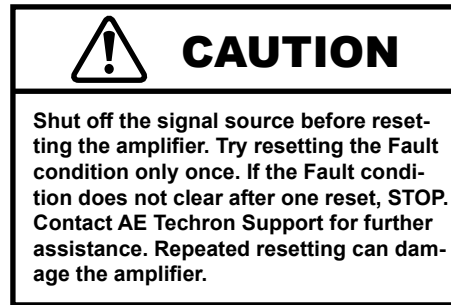

7.9 Factory Service

If the troubleshooting procedures are unsuccessful, the amplifier may need to be returned for Factory Service. All units under warranty will be serviced free of charge (customer is responsible for one-way shipping charges as well as any custom fees, duties, and/or taxes). Please review the Warranty at the beginning of this manual for more information.

All service units must be given Return Authorization by AE Techron, Inc. before being returned. Return Authorizations can be requested on our website or by contacting our Customer Service Department.

Please take extra care when packaging your amplifier for repair. It should be returned in its original packaging or a suitable alternative. Replacement packaging materials can be purchased for a nominal fee.

Please send all service units to the following address and be sure to include your Return Authorization Number on the box.

AE Techron, Inc.
Attn: Service Department / RMA#
2507 Warren Street
Elkhart, IN 46516

Appendix A: Interlock I/O Connector Pinouts and Functions

Pin #	Function	Description	Signal Type	Level when Asserted	Level when Deasserted	Notes	Applications
1	Amplifier Output	Used for driving Follower amplifiers; monitoring amplifier output voltage	AC or DC	Can be greater than $\pm 200V$ peak	0V	Used for monitoring amplifier output voltage; driving Follower amplifiers in multi-amp Push/Pull and Parallel systems (some versions) and Series systems (all versions). Wired to amplifier output. Do not connect to any impedance of less than 10K ohm.	Voltage Monitoring: Connect a voltage meter to monitor the output voltage being produced by the amplifier. Connect across PIN 1 (Amp Out) and PIN 10 (Sampled Common).
2	Sampled Common	Load connected here for Current sense	AC or DC	Up to $\pm 2V$ peak relative to Common	0V	Used for driving Follower amplifiers in multi-amp Push/Pull and Parallel systems (some amplifiers) and Series systems (all amplifiers), controlled voltage or controlled current mode.	Driving Follower Amplifiers: Amplifier External Reference, 2V peak maximum from PIN 14 (Common).
3	+1 IN	Differential Follower input	AC or DC	Can be greater than $\pm 200V$ peak	0V	Only used in multiple amplifier configurations - Series mode.	Can accept output of PIN 1 (Amplifier Output) OR PIN 2 (Sampled Common) from Master device when in Follower mode.
4	Interlock	Amplifier Interlock input	DC	0V to 8V	10V to 15V	When "low", forces to Standby; when allowed to float, allows Run (if amplifier is "Ready"). IMPORTANT: amplifiers must be configured for Run mode at startup (factory default) or the Run button must be pressed at the amplifier front panel at startup.	Remote to Standby: Short PIN 4 of amplifier to Digital Ground (PIN 17) using dry contact switch or optocoupler. When closed, places amplifier in Standby. Multi-amplifier Systems, Simultaneous Enable or Disable of amplifiers: Daisy-chain Interlock (PIN4) across amps (if sharing the same Sampled Common power connections). Optocoupler must be used for multi-amps in series.
5	Amp Ready	Ready output of amplifier	DC	0V	-14V	Normally reserved for OPTOC use; not recommended for normal customer use. Line has series resistor and unloaded will go from 0V (not ready) to -15V (ready), with an OPTOC BNC card the signal will go from 0V (not ready) to -1.2Vdc (ready)	Not recommended for normal customer use.
6	I MON +	Differential Current Monitor +	AC or DC	7212, 7224, 7224RLY, 7234: 5A/V 7548, 7548RLY, 7794, 7796, 7796RLY, 7796HC: 20A/V		Output current produced per voltage detect.	Current Monitoring: Connect a voltage meter to monitor the output current being produced by the amplifier. For unbalanced, for each 1V detected, current output is 5A (7212/7224/7224RLY/7234) or 20A (7548/7548RLY/7794/7796/7796RLY/7796HC).
7	None	No connection					Currently not used.

Pin #	Function	Description	Signal Type	Level when Asserted	Level when Deasserted	Notes	Applications
8	Blanking Input	Blanking control (Customer Mute)	DC	0Vdc	5-6 Vdc	The blanking circuit shuts down the amplifier output stage in less than 10 μ s.	Blanking (Customer Mute): Build a switchable circuit using an external, isolated 5V power supply that can apply a +5V signal to PIN 8. Connect across PIN 8 (Blanking) and PIN 18 (Blanking Return).
9	Temperature Monitor	Temperature Monitor	DC	(VDC * 100) – 273 = degrees Celsius	3.5 - 5Vdc output is muted	This circuit has a 1K build-out resistor. Make sure the monitor function has sufficient impedance to avoid accidentally influencing status. Most digital multimeters have an input impedance of 1 megohm and would work well for this application.	Temperature Monitoring: Connect a voltage meter to monitor the temperature at the heatsinks.
10	Sampled Common	Amp Analog Ground				Amplifier ground.	Can be used as a reference of the amplifier for status reporting applications. See OverTemp (PIN 11), Run (PIN 12), Overload (PIN 23), and OverVoltage (PIN 24).
11	OverTemp Out	Over-temperature output	DC	-24V	0V	When amp is normal, this pin is pulled to -24V through a 47.5K-ohm resistor; when amp is in OverTemp state, this pin is grounded. Do not exceed 7 milliamps.	Remote Signal of Over-Temperature Condition: LED, when lit, signals Over Temperature condition. Use a 6 mA series resistor of 4.7K-ohm for LED or OPTO, tie to -24V source (PIN 13).
12	Run	Amplifier Run output	DC	-24V	0V	When amp is in Standby mode, this pin is pulled to -24V; when amp is in Run mode, this pin is grounded, energizing Mains Relays and allowing drive for an external LED. DO NOT exceed 7mA; DO NOT ground this pin as this will enable Main Power Relays.	Remote Signal of Run Condition: LED, when lit, signals Run state. Use a 6mA series resistor of 4.7K-ohm for LED or OPTO, tie to -24V source (PIN 13).
13	-24V	-24V Power Output	DC			-24V dc, 30 mA max	Internally tied for use in status reporting applications. See OverTemp (PIN 11), Run (PIN 12), Overload (PIN 23), and OverVoltage (PIN 24).
14	Common	Ground before Sense Resistors				Current monitor reference. Voltage between Common and Sampled Common is voltage on the Current Sense resistor.	Possibly series amplifiers will not need current reporting on the High side amp, since its current will be same as Master.
15	-1 IN	Differential Follower Input	AC or DC	Up to 200V peak	0V	Only used in multiple amplifier configurations, Series mode.	Can accept output of PIN 1 (Amplifier Output) OR PIN 2 (Sampled Common) from Master device when in Follower mode.
16	+24V	+24V Power Output	DC			+24V dc, 30 mA max.	Used in status reporting applications. See OverTemp (PIN 11), Run (PIN 12), Overload (PIN 23), and OverVoltage (PIN 24).

Pin #	Function	Description	Signal Type	Level when Asserted	Level when Deasserted	Notes	Applications
17	Digital Ground	Digital circuitry ground - Interlock Common	DC	0V	0V		Used with PIN 25 (Reset) for Remote Reset from Standby or Stop after Error. Used with PIN 4 (Interlock) for simultaneous remote to Standby of all amps in a multi-amplifier system.
18	Blanking Return	Used for blanking circuit activation					
19	I MON – (alt.: OEM App)	Differential Current Monitor – ; (- Input Monitor, OEM only)	AC or DC	7212, 7224, 7224RLY, 7234: 5A/V 7548, 7548RLY, 7794, 7796, 7796RLY, 7796HC: 20A/V		Inverted I MON+ (PIN 6). Output current produced per voltage detect.	Current Monitoring: Connect a voltage meter to monitor the output current being produced by the amplifier. For each 1V detected, current output is 5A (7212/7224/7224RLY/7234) or 20A (7548/7548RLY/7794/7796/7796RLY/7796HC).
20	I SUM1–	Multiple Amplifier Summing, Amplifier 1	DC			Planned for use in multiple amplifier configurations - paralleled and running Controlled Current Mode	Currently not used.
21	I SUM2–	Multiple Amplifier Summing, Amplifier 2	DC			Planned for use in multiple amplifier configurations - paralleled and running Controlled Current Mode	Currently not used.
22	I SUM3–	Multiple Amplifier Summing, Amplifier 3	DC			Planned for use in multiple amplifier configurations - paralleled and running Controlled Current Mode	Currently not used.
23	OverLoad Out	Overload output (amplifier output is clipping).	DC	–24V	0V	When amp is normal, this pin is pulled to –24V through a 47.5K-ohm resistor; when amp is in Overload state, this pin is grounded. Do not exceed 6 milliamps.	Remote Signal of Overload Condition: LED, when lit, signals Overload condition. Use a 6mA series resistor of 4.7K-ohm for LED or OPTO, tie to –24V source (PIN 13).
24	OverVoltage Out	Overvoltage output (High AC line voltage).	DC	–24V	0V	When amp is normal, this pin is pulled to –24V through a 47.5K-ohm resistor; when amp is in Overvoltage state, this pin is grounded. Do not exceed 6 milliamps.	Remote Signal of Overvoltage Condition: LED, when lit, signals Overvoltage condition. Use a 6mA series resistor of 4.7K-ohm for LED or OPTO, tie to –24V source (PIN 13).
25	Reset	Reset	DC	–15V	0V	Tie to PIN 13 (–24V dc) and create a –15V dc source; <2mA required for reset. Connect the –15V dc source to PIN 25 (Reset) through a 1K buffer resistor to reset.	Reset from Standby: Use a dry contact switch and voltage regulator to return amp to Ready/Run condition after Overload conditions. Assert –15V for at least 100 ms to clear error condition.
Gray shaded areas indicate pin not used / feature not implemented.						Blue shaded areas indicate used only in multi-amplifier systems.	