



## 7548RLY

Four Quadrant Power Amplifier  
for Protection Relay Production  
Testing and Commissioning

### Performance Overview:

Maximum Current Output (0.5Ω):	100 Ap (70 A <sub>RMS</sub> )
Maximum Output Voltage:	195 V <sub>p</sub>
Controlled-Current Bandwidth (0.25Ω load):	DC - 10 kHz
Standard Transconductance (from short to 1Ω load):	20 ±0.2%
Unit to Unit Phase Error (60 Hz):	±0.1°
Residual Noise (40 Hz - 600 Hz):	<2.5 mA <sub>p</sub>

AE Techron's **7548RLY** amplifier was created to meet the demanding requirements of the power utility industry. With an output capability of 100 Ap, the 7548RLY is powerful enough to put protection relays, fuses and other critical components through a full range of tests. It is capable of a controlled voltage bandwidth of DC - 100 kHz, and a controlled current bandwidth of DC - 10 kHz. The low noise floor, low distortion and minimal phase error of the 7548RLY make it the ideal amplifier for power grid modeling.

### Features:

- High compliance voltage allows the 7548RLY to drive electromechanical relays directly.
- Maintains phase accuracy for any load from a dead short to 0.25 ohms.
- Front panel indicators for rapid assessment of amplifier status.
- Installs in a standard 19-inch rack; or stands alone for bench-top operation.
- Shipped ready to operate from three-phase, 208VAC (±10%), 47-60 Hz, 30A service. 400VAC (±5%) 15A model available on request.
- Protection circuitry protects from input overloads, improper output connection (including shorted and improper loads), over-temperature, over-current, and supply voltages that are too high or low.
- Backed by AE Techron's comprehensive, 3-year, no-fault warranty.

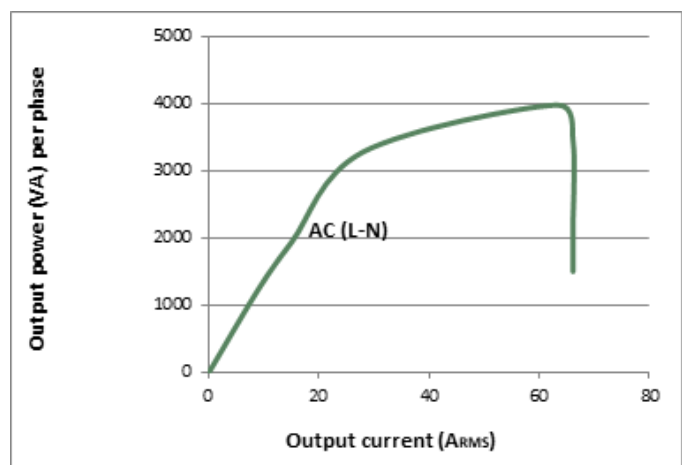

## Specifications

### Performance

\*All loads from 8-ohm to short are stable with 2 mH in series.

**Controlled-Current Bandwidth (0.25-ohm load):**  
DC - 10 kHz

**Maximum Output Current (0.5-ohm load):**  
70 ARMS (100 Ap)

**Maximum Output Voltage:** 195 Vp

**Maximum Output Power:** Dependent on load and frequency

**Load Constraint for Maximum Output:**  $0.5\Omega + 200 \text{ mH}^*$

**Output Offset Current:** Less than 10.0 mA DC peak

**Standard Transconductance (from short to 1-ohm load):**  
 $20 \pm 0.2\%$

**Unit to Unit Phase Error (60 Hz):**  $\pm 0.1$  degrees

**Residual Noise (40 Hz to 600 Hz):** Less than 2.5 mAp

**Out Accuracy:** Less than  $\pm 1\%$

### Input Characteristics

**Balanced with ground:** Three terminal barrier-block connector, 20 k $\Omega$  differential

**Unbalanced:** BNC connector, 10 k $\Omega$  single-ended

**Max Input Voltage:**  $\pm 10\text{V}$ , balanced or unbalanced

**Common Mode Rejection Ratio (40 Hz - 600 Hz):**  
-58 dB minimum

### Status Display, Control, I/O

**Front Panel LED Displays indicate:** Ready, Standby, Fault

**Soft Touch Switches for:** Run, Stop, Reset

**LCD Display:** Can be configured for up to four simultaneous displays reporting one, two, or all four of the following: Vp, VRMS, Ap, ARMS. Also reports any fault conditions that occur and suggests corrective action.

**Back Panel Power Connection:** NEMA-style locking receptacle; matching AC connector also included

**Signal Output:** 4-position terminal barrier block (OUTPUT / COMMON / SAMPLED COMMON / CHASSIS GROUND); resistor installed between SAMPLED COMMON AND CHASSIS GROUND is a 2.7-ohm, 2W, 5%, metal-oxide resistor

**Signal Input:** User-selectable BNC or Barrier Strip, Balanced or Unbalanced

**Interlock Connector:** 25-pin D-sub connector used for amplifier control and status applications; also used in multi-amplifier applications

### Communication Capabilities

**Current Monitor:** 20A/V  $\pm 1\%$ ; 10A/V  $\pm 1\%$  (differential configuration)

**Reporting:** System Fault, Over Temp, Over Voltage, Over Load

**Remote Control via Interlock Connector:** Force to Standby, Reset after a Fault

### Protection

**Over/Under Voltage:**  $\pm 10\%$  ( $\pm 5\%$  for 400VAC version) from specified supply voltage amplifier is forced to Standby

**Over Current:** Breaker protection on both main power and low-voltage supplies

**Over Temperature:** Separate output transistor, heat sink, and transformer temperature monitoring and protection

### Physical Characteristics

**Chassis:** The amplifier is designed for stand-alone or rack-mounted operation. The chassis is aluminum with a black powder-coat finish. The unit occupies seven EIA 19-inch-wide units.

**Weight:** 110 lbs (50 kg), Shipping 122 lbs (55.3kg)

**AC Power:** Three-phase, 208V AC ( $\pm 10\%$ ), 47-60 Hz, 30A AC service; (400V AC ( $\pm 10\%$ ), 15A model available)

**Operating Temperature:** 10°C to 50°C (50°F to 122°F), maximum output power de-rated above 30°C (86°F.)

**Humidity:** 70% or less, non-condensing

**Cooling:** Forced air cooling from front to back through removable filters via six 100ft<sup>3</sup>/min. fans. No space is required between rack-mounted amplifiers. Air filters are removeable from the rear via one fastener per side and may be eliminated if cabinet filtration is provided.

**Dimensions (HxWxD):** 8.75" in. x 19" in. x 22.8" in. (22.2 cm x 48.3 cm x 57.8 cm)

## Accuracy

Amplitude vs. Frequency at 1V input, 20A output, amplifier transconductance set to 20			
Load	Input Signal	Transconductance	
		1 kHz	100 Hz
2 ohms	Sine	19.9	20
1 ohm	Sine	20	20
½ ohm	Sine	20	20
Short (unimpeded wire)	Sine	20	20

## Pulse/Burst Specifications

Load	Duration	Waveform	Output Power
0.5 ohms	20 seconds	60 Hz Sine	57 Arms / 80.6 Apeak
		DC	25 Apeak
	0.5 second	60 Hz Sine	66 Arms / 93 Apeak
		DC	70 Apeak
	0.2 second	60 Hz Sine	66 Arms / 93 Apeak
		DC	70 Apeak

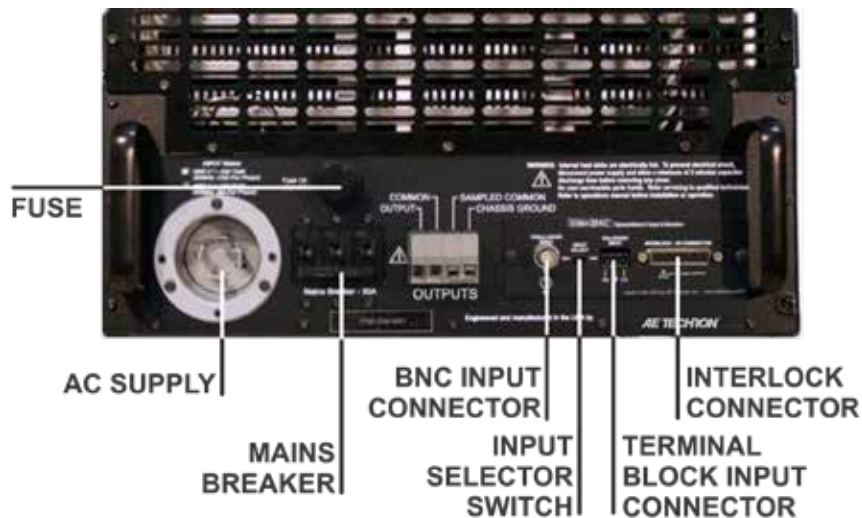
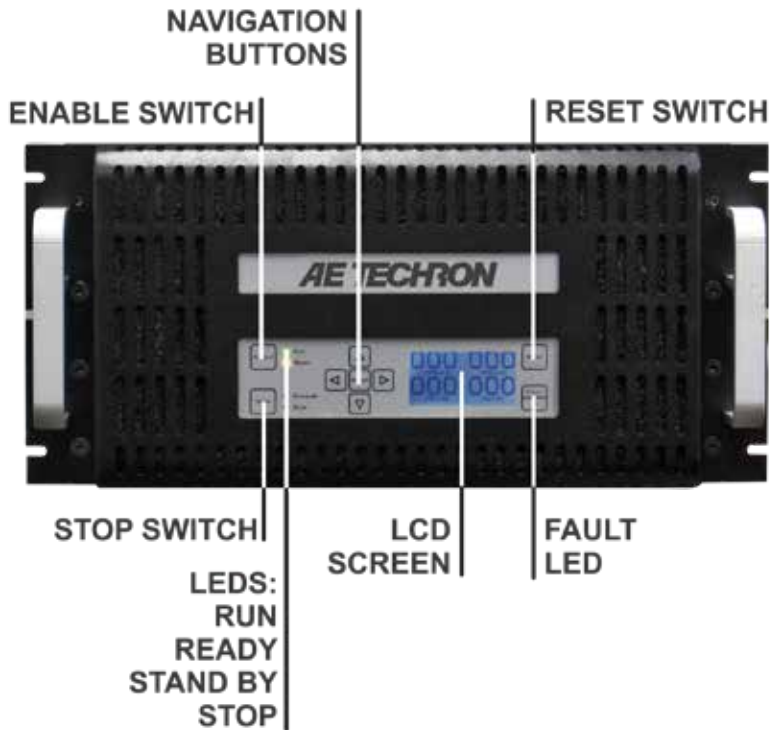

**CE** 400V versions of this product bear the CE mark

*Please note that the handles are not to be used for carrying the amplifier and only lift the device using a two-person technique.*