

AETECHRON



7800 Series

**High-Power, High-Precision
AC/DC Linear Power Amplifiers**

Operation Manual

574.295.9495 | www.aetechron.com
2507 Warren Street, Elkhart, IN 46516

Three-Year, No-Fault Warranty

SUMMARY OF WARRANTY

AE TECHRON INC., of Elkhart, Indiana (Warrantor) warrants to you, the ORIGINAL COMMERCIAL PURCHASER and ANY SUBSEQUENT OWNER of each NEW **AE TECHRON INC. product, for a period of three (3) years from the date of purchase, by the original purchaser (warranty period) that the product is free of defects in materials and workmanship and will meet or exceed all advertised specifications for such a product. We further warrant the new AE Techron product regardless of the reason for failure, except as excluded in the Warranty.**

ITEMS EXCLUDED FROM WARRANTY

This AE Techron Warranty is in effect only for failure of a new AE Techron product which occurred within the Warranty Period. It does not cover any product which has been damaged because of any intentional misuse, or loss which is covered under any of your insurance contracts. This warranty does not extend to any product on which the serial number has been defaced, altered, or removed. It does not cover damage to loads or any other products or accessories resulting from **AE TECHRON INC.** product failure. It does not cover defects or damage caused by the use of unauthorized modifications, accessories, parts, or service.

WHAT WE WILL DO

We will remedy any defect, regardless of the reason for failure (except as excluded), by repair or replacement, at our sole discretion. Warranty work can only be performed at our authorized service centers or at our factory.

Expenses in remedying the defect will be borne by **AE TECHRON INC.**, including one-way surface freight shipping costs within the United States. (Purchaser must bear the expense of shipping the product between any foreign country and the port of entry in the United States and all taxes, duties, and other customs fees for such foreign shipments.)

HOW TO OBTAIN WARRANTY SERVICE

When you notify us or one of our authorized service centers of your need for warranty service, you will receive an authorization to return the product for service. All components must be shipped in a factory pack or equivalent which, if needed, may be obtained

from us for a nominal charge. We will take corrective actions and return the product to you within three weeks of the date of receipt of the defective product, or will make available to you a product of equal or better performance on temporary loan until your product can be repaired or replaced and returned to you. If the repairs made by us are not satisfactory, notify us immediately.

DISCLAIMER OF CONSEQUENTIAL AND INCIDENTAL DAMAGES

You are not entitled to recover from us any consequential or incidental damages resulting from any defect in our product. This includes any damage to another product or products resulting from such a defect.

WARRANTY ALTERATIONS

No person has the authority to enlarge, amend, or modify this warranty. The warranty is not extended by the length of time for which you are deprived of the use of this product. Repairs and replacement parts provided under the terms of this warranty shall carry only the unexpired portion of this warranty.

DESIGN CHANGES

We reserve the right to change the design of any product from time to time without notice and with no obligation to make corresponding changes in products previously manufactured.

LEGAL REMEDIES OF PURCHASER

There is no warranty that extends beyond the terms hereof. This written warranty is given in lieu of any oral or implied warranties not contained herein. We disclaim all implied warranties, including, without limitation, any warranties of merchantability or fitness for a particular purpose. No action to enforce this Warranty shall be commenced later than ninety (90) days after expiration of the warranty period. This statement of warranty supersedes any others contained in this manual for AE Techron products.

AE TECHRON INC. **Customer Service Department**

2507 Warren St. Elkhart, IN, 46516, U.S.A.
(574) 295-9495
www.aetechron.com

Contents

1	About the 7800 Series	5
	Key Performance Capabilities.....	5
	Features	5
2	System Setup	6
2.1	Safety First	6
2.2	Unpacking and Installing	6
2.3	Check Contents.....	6
2.4	7800 Series Cabinet Location	6
2.5	Connections and Startup.....	6
2.6	Startup Procedure	12
3	Operation	13
3.1	System Controls and Connectors.....	13
3.2	Amplifier Module Controls and Indicators.....	13
3.3	Back-Panel Controls and Connectors	18
4	Advanced Configuration	20
4.1	Factory Defaults	20
4.2	Accessing the Main Board.....	20
4.3	Configuration Settings Controlled by DIP Switches	20
4.4	Configuration Settings Controlled by Jumpers.....	23
4.5	Adjusting the Bi-Level Power Supply Switch.....	23
5	Applications	25
5.1	Remote Status and Control using the SIM Interlock I/O Connector	25
5.2	Controlled Current Operation	30
6	Maintenance	35
6.1	Clean Amplifier Filter and Grills	35
6.2	Clean Cabinet Interior	35
7	Troubleshooting	36
7.1	Factory Service:	37

7800 Series Models: Maximum Output Capabilities

Model	Volts	Amps	Watts
7810-50-200	50	200	10 kW
7810-100-100	100	100	10 kW
7810-200-50	200	50	10 kW
7815-50-300	50	300	15 kW
7815-100-150	100	150	15 kW
7815-300-50	300	50	15 kW
7820-50-400	50	400	20 kW
7820-100-200	100	200	20 kW
7820-200-100	200	100	20 kW

Key Performance Capabilities

Output Power	Up to 20 kVA continuous, 40 kVA short term
Current	Up to 400A continuous, 800A short term
Voltage	Up to ± 500 Vp
Bandwidth	DC to 60 kHz
Slew Rate	40V/mS
THD	Less than 0.25% (DC - 20 kHz)
DC Drift	Less than ± 400 μ V (from room temp to thermal shut down)

1 About the 7800 Series

AE Techron's 7800-Series AC power amplifiers are durable, four-quadrant, DC-enabled, low-noise, wide-bandwidth amplifiers. This combination of features and abilities makes them a great choice for a large number of research and industrial applications.

7800 series amplifiers are a great solution if bandwidth and/or system noise is a problem. They are able to drive low-impedance loads at frequencies of up to 60 kHz. Because they utilize a linear circuit topology, AE Techron 7800 series amplifiers have no switching noise in their output and very low radiated EMI. This results in THD and noise floors that are much lower than what is possible with traditional switch mode amplifiers, making them ideal for applications that require either high precision or, because of sensitive measurements, cannot tolerate the radiated noise associated with switch mode amplifiers.

7800 series amplifiers are tough, both physically and electrically. 7800 series models have been used for conducting experiments on a Navy warship, controlling a magnetic field in a fusion experiment, and driving DUT's while absorbing back EMF when there is a failure.

The 7800 series is designed and built for applications where large surge currents or long duration

Features

- Stable when driving a wide range of resistive, inductive or capacitive loads
- Four-quadrant operation operation (source and sink)
- Field-selectable controlled-voltage or controlled-current operation
- Protection circuitry protects the amplifier from input overloads, improper output connection (including shorted and improper loads), over-temperature, over-current, and supply voltages that are too high or low

power is needed. This makes them ideal for applications where power or duty cycle requirements are greater than is possible with consumer- or pro-audiograde amplifiers. Because power ratings are continuous, AE Techron amplifiers often produce between 4 and 8 times more power than a similarly rated consumer amplifier.

7800 Series amplifiers are modular and scalable. They are available in three standard power ranges: 10kVA, 15kVA and 20kVA. Within each power range, models are available that have been optimized for load impedances from 0.1 ohm to 8 ohms.

2 System Setup

2.1 Safety First

Throughout these instructions, special emphasis is placed on good safety practices. The following graphics are used to highlight certain topics that require extra precaution.

 DANGER
DANGER represents the most severe hazard alert. Extreme bodily harm or death will occur if these guidelines are not followed. Note the explanation of the hazard and instruction for avoiding it.

 WARNING
WARNING alerts you to hazards that could result in severe injury or death. Note the explanation of the hazard and the instructions for avoiding it.

 CAUTION
CAUTION indicates hazards that could result in potential injury or equipment or property damage. Once again, note the explanation of the hazard and the instructions for avoiding it.

2.2 Unpacking and Installing

Your amplifier will be delivered to the ship-to address enclosed in a wooden crate with special, shock-absorbing pads. With the addition of packaging, the unit can weigh several hundred pounds (kilograms).

To uncrate the product, follow the **Unpacking Your Product** instructions included with your shipment. The cabinet can be removed from the crate using

 WARNING
Use caution when using a forklift to move this cabinet. Crushing bodily injury can result if care is not taken during uncrating and installation.

the built-in hinged ramp or by using a forklift or other suitable equipment to glide the amplifier from the crate.

Forklift provisions are provided in the base of the cabinet to facilitate this removal procedure (see **Figure 2.1**).



Figure 2.1 – Provisions in Cabinet Base for Forklifts

 CAUTION
Use caution when inserting the forklift tynes into the cabinet's lifting base. Do not drag the tynes heavily against the cabinet when entering or exiting the base. Keep the tynes level at all times while handling the cabinet.

The amplifier has been tested and inspected for damage before leaving the factory. Carefully unpack and inspect the product for damage. **Please note any damage for future reference and notify the shipping company immediately if damage is found.** Also, please save the shipping crate and pallet as evidence of damage and/or for returning the amplifier for repair.

2.3 Check Contents

In addition to the 7800 Series cabinet, your shipment should include the following:

1. Quick Start Guide
2. 7800 Series Operation Manual on USB drive



2.4 7800 Series Cabinet Location

7800 Series cabinets are mounted on wheels to allow rolling on a flat, smooth surface. The cabinet wheels should be used only for moving the cabinet over a short distance to position the cabinet in its permanent location. DO NOT use the cabinet wheels to move the cabinet over long distances. To avoid possible tipping, always push the amplifier from the front and avoid rough or pitted surfaces.

Locate your cabinet near a three-phase power source. Allow enough clearance at the front and back of the cabinet to allow adequate airflow and hot air discharge through the cabinet rear. See **Figure 2.2** for clearance recommendations.

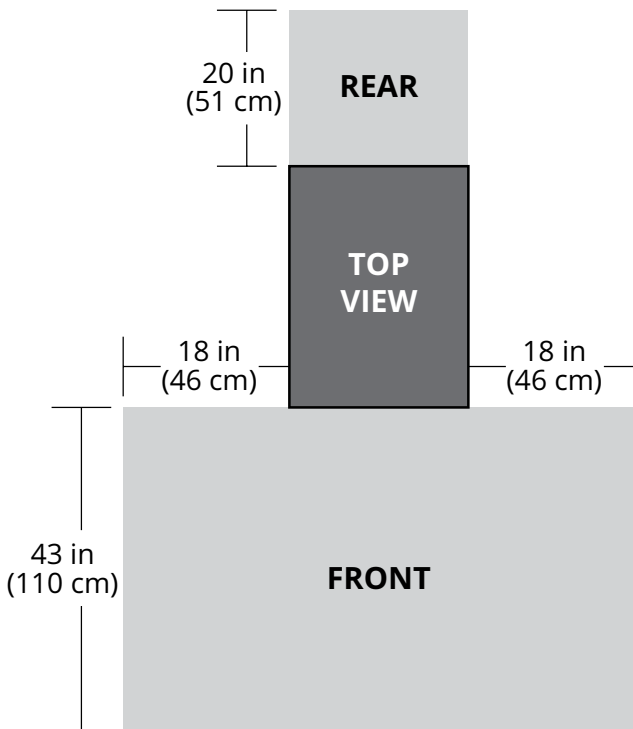

Figure 2.2 – Clearance Recommendations for Cabinet Placement

All of the wheels on the cabinet are equipped with a leveling pad that can be used to adjust the height of each wheel (see **Figure 2.3**). This leveling mechanism will also act to lock each wheel in place and prevent unintentional movement of the cabinet.

Two covers have been provided to insert into fork lifting openings at the front of the cabinet once the cabinet has been set in its final location.



Figure 2.3 – Leveling pads on Cabinet Wheels

2.5 Connections and Startup

This section details the wiring and startup procedures for a 7800 series amplifier operating in Controlled-Voltage mode (factory default). Before connecting the amplifier inputs and outputs, make sure the AC power is disconnected.

2.5.1 Connecting the Load

Please refer to the connection instructions for your 7800-Series model.

Preparation and Cautions

Before connecting the amplifier, make sure the AC power is disconnected.

Output Connections for Models 7810-200-50 and 7815-300-50

Connect your load to the four-position terminal barrier block connectors labeled OUTPUTS located inside the cabinet on the back panel of the Master amplifier module (upper-most amplifier module in the cabinet) and the last Follower amplifier mod-

ule. On model 7810-200-50, the last Follower amplifier module is the other amplifier module in the cabinet. On model 7815-300-50, the last Follower amplifier module is the lowest module in the cabinet. See **Figure 2.3**.

NOTE: The 7800 series amplifier comes with a factory-installed 2.7-ohm, 2W, 5%, metal-oxide resistor connecting the terminals marked “SAMPLED COMMON” and “CHASSIS GROUND” on the Master amplifier module back panel (see **Figure 2.4**). This resistor should NOT be removed. **WARNING:** Removing this resistors can cause dangerous output and/or damage to the load.

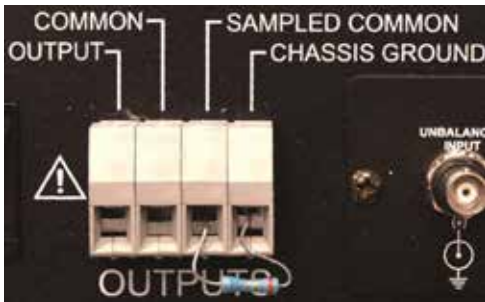

Figure 2.4 – Close-up of the Output Terminal Resistor

The four-position terminal barrier blocks accept up to #4 AWG wire. Always use the appropriate wire size and insulation for the maximum current and voltage expected at the output. Never connect the output of the amplifier to any other model amplifier,

Input and Output Wire Routing



Figure 2.5 – Grommet for routing input and output wiring into the system case

power supply, signal source, or other inappropriate load; fire can result.

Complete the following steps to connect the load to the 7800 series system output connectors.

1. Route your output cables through the grommet in the panel located at the top of the cabinet back. See **Figure 2.5**. Make sure the cable is long enough to reach the back panel of the the lowest amplifier module in the cabinet.
2. Locate the four-position terminal barrier block on the back panel of the Master amplifier module (see **Figure 2.6**). Connect the negative terminal of the load to the SAMPLED COMMON terminal.

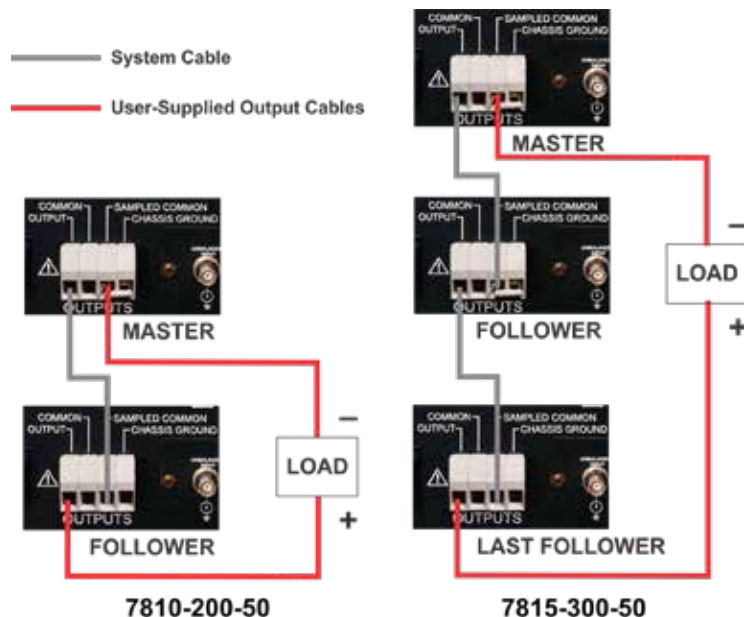

Figure 2.6 – Connecting the load

NOTE: Alternately, the COMMON terminal may be used when operating in Controlled-Voltage mode; however, the integrated current monitor will not function if the COMMON terminal is used, since it depends on feedback from the Sampled Common terminal. For operation in Controlled-Current mode, the SAMPLED COMMON terminal must be used.

3. Locate the four-position terminal barrier block on the back panel of the last Follower amplifier module (see **Figure 2.6**). Connect the load's positive terminal to the OUTPUT terminal.
4. Optionally, the "CHASSIS GROUND" terminal can be connected to an external ground point such as the rack chassis.

Output Connections for Models 7810-50-200, 7810-100-100, 7815-50-300, 7815-100-150, 7820-50-400, 7820-100-200, and 7820-200-100.

Connection to the output of the amplifier is to a four-position terminal barrier block labeled OUTPUTS located inside the cabinet on the back panel of the Master amplifier module (upper-most amplifier module in the cabinet). See **Figure 2.7**.

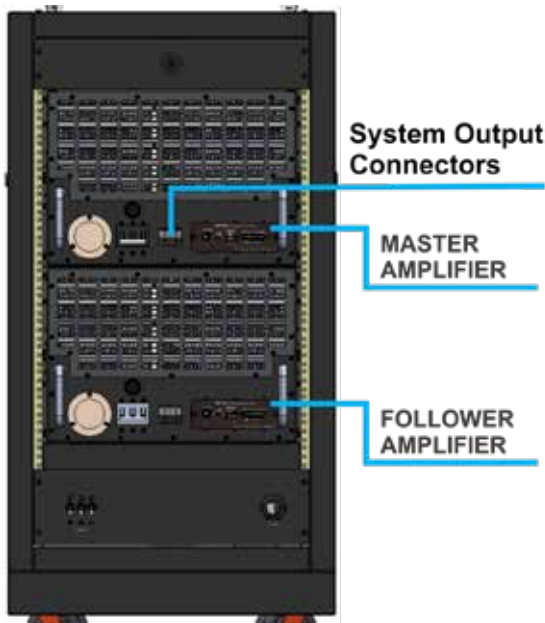

Figure 2.7 – Location of the system output connectors for models 7810-50-200, 7810-100-100, 7815-50-300, 7815-100-150, 7820-50-400, 7820-100-200 and 7820-200-100

NOTE: The 7800 series amplifier comes with a factory-installed 2.7-ohm, 2W, 5%, metal-oxide resistor connecting the terminals marked "SAMPLED COMMON" and "CHASSIS GROUND" on each amplifier module back panel (see **Figure 2.8**). These resistors should NOT be removed. **WARNING:** Removing any of these resistors can cause dangerous output and/or damage to the load.

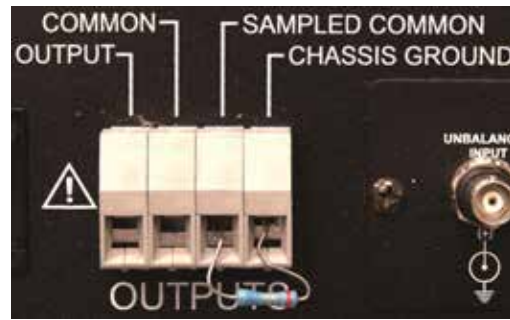

Figure 2.8 – Close-up of the Output Terminal Resistor

The four-position terminal barrier block accepts up to #4 AWG wire. Always use the appropriate wire size and insulation for the maximum current and voltage expected at the output. Never connect the output of the amplifier to any other model amplifier, power supply, signal source, or other inappropriate load; fire can result.

Complete the following steps to connect the load to the 7800 series system output connectors.

1. Route your output cable through the grommet in the panel located at the top of the cabinet back. See **Figure 2.9**. Make sure the cable is long enough to reach the back panel of the Master amplifier module.

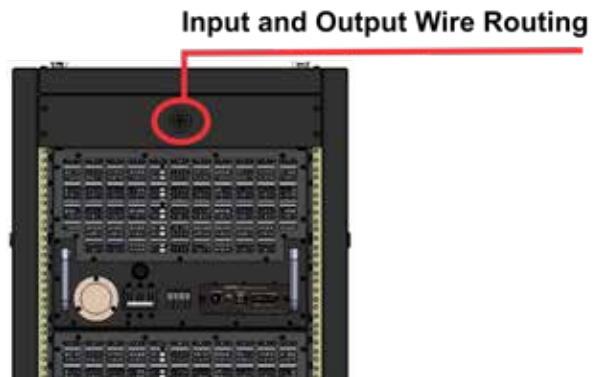

Figure 2.9 – Grommet for routing input and output wiring into the system case

2. Locate the four-position terminal barrier block on the back panel of the Master amplifier module (see **Figure 2.10**). Connect the negative terminal of the load to the SAMPLED COMMON terminal.

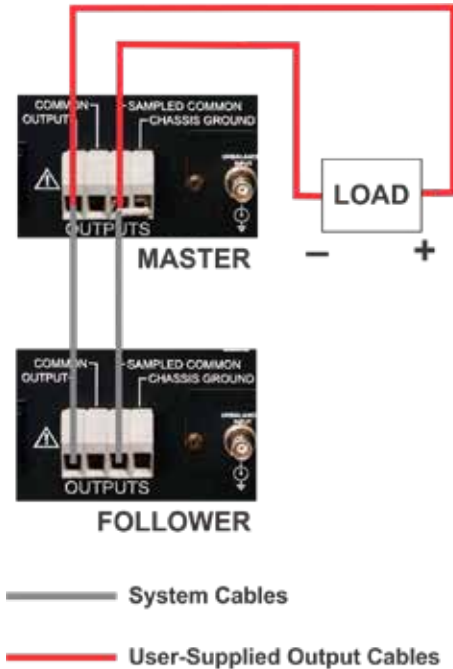

Figure 2.10 – Connecting the load

NOTE: Alternately, the COMMON terminal may be used when operating in Controlled-Voltage mode; however, the integrated current monitor will not function if the COMMON terminal is used, since it depends on feedback from the Sampled Common terminal. For operation in Controlled-Current mode, the SAMPLED COMMON terminal must be used.

3. Connect the load’s positive terminal to the amplifier’s OUTPUT terminal.
4. The “CHASSIS GROUND” terminal can be connected to an external ground point such as the rack chassis.

2.5.2 Connecting the Input Signal

The signal is connected to the amplifier by routing the input cable through the grommet in the panel located at the top of the cabinet back, and then connecting to the “SIM (Specialized Input Module Card)” located on the Master amplifier back panel (see **Figure 2.11**). The SIM card includes both an

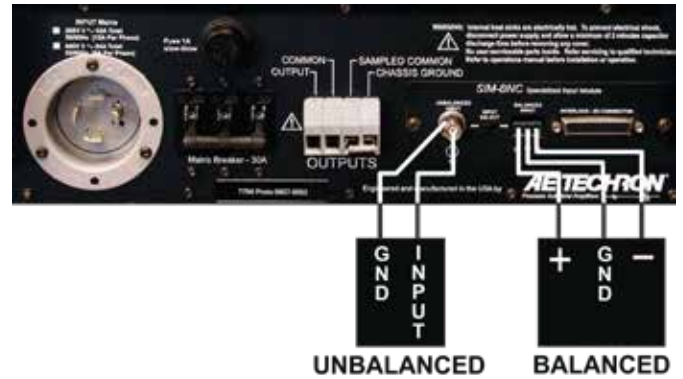

Figure 2.11 – Wiring for unbalanced or balanced input connector

Unbalanced Input BNC jack and a Balanced Input “WECO” terminal block connector, an Input Select switch, and an Interlock – I/O Connector. See the **Applications** section for information on using the Interlock – I/O Connector.

Position the **Input Select** switch to the left to select the Unbalanced Input connector and to the right to select the Balanced Input connector. Note that **when the Input Select switch is in the right position, both Unbalanced and Balanced Input connectors are enabled.**

IMPORTANT: The Input Select switch also functions as a Ground Lift switch for the Unbalanced Input connector. If circulating currents/ground loops/60-Hz hum occur when using the Unbalanced Input, move the Input Select switch to the right to lift the ground on the connector.

WARNING

ELECTRIC SHOCK HAZARD. Power supply wiring should only be performed by a qualified, licensed electrician.

2.5.3 Connect the Power Source

Disconnect and Inlet Wiring Protection

A safety disconnect device for the AC mains input must be installed so that it is both nearby and accessible to the operator. The disconnect must be clearly labeled.

Inlet wiring must support the rated current.

The amplifier must be protected by fuses or circuit breakers that protect the power inlet wiring with a maximum rating no more than the rated current for the product model.

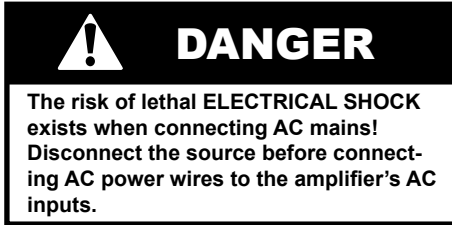

AC Inlet Connections

Always operate the amplifier from the proper AC mains. The 7800 series amplifier requires three-phase, 50-60 Hz, 208 VAC (or optional 400 VAC) with no more than 10% variance above or below the line voltage. The amplifier will not operate properly outside these limits.

Connect protective grounding terminal to AC mains ground before turning on power to prevent electric shock hazard.

Do not disconnect or disable the protective grounding connection. Doing so causes a potential electrical shock hazard.

Complete the following steps to connect the amplifier to your three-phase power source:

1. Wear safety goggles.
2. Disconnect your AC power source.
3. Open the access door on the back of the amplifier and locate the fuse and AC inlet panel near the bottom of the amplifier. Locate the power block, which is mounted behind the fuse and AC inlet panel (see **Figure 2.12**).
4. Route the 10 AWG, 5 conductor power input cable into the amplifier through the cable strain relief (located on the fuse and AC inlet panel).
5. Connect to the AC mains barrier strip as shown in **Figure 2.13**.
6. If connecting to an AC power cord, verify connector wiring for phases, neutral and safety ground. Verify that proper phase, neutral and safety ground connections have been made at the AC mains breaker.

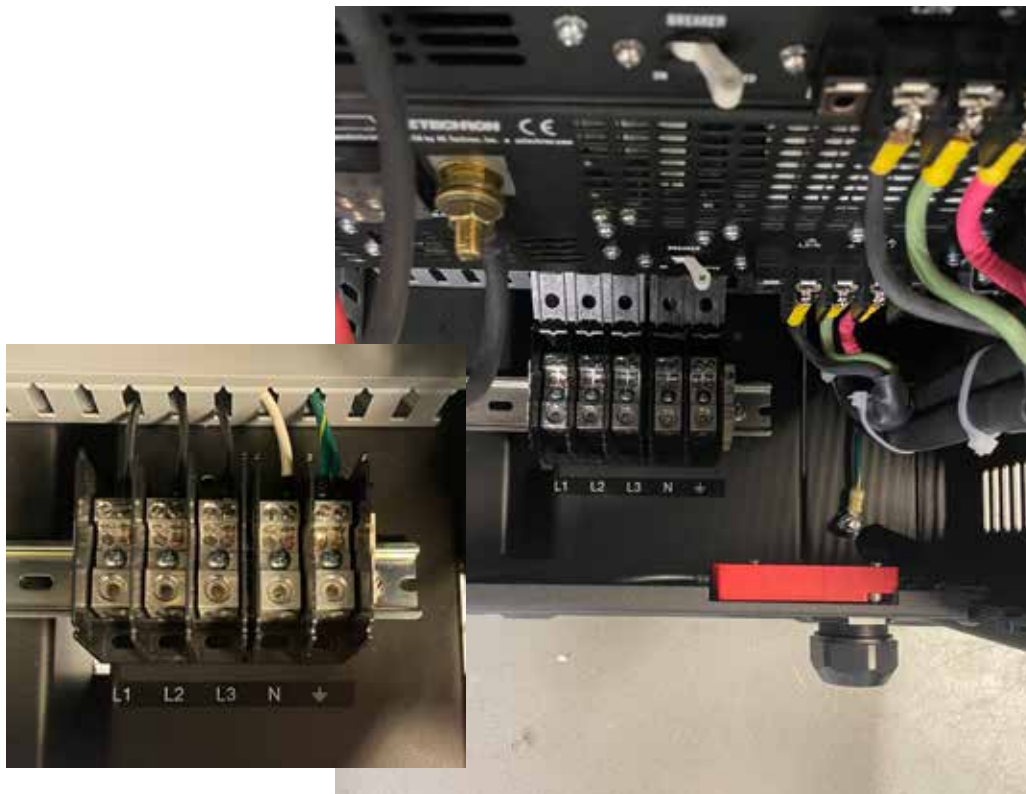

Figure 2.12 – Location of AC Mains Barrier Strip with labeling detail (inset)

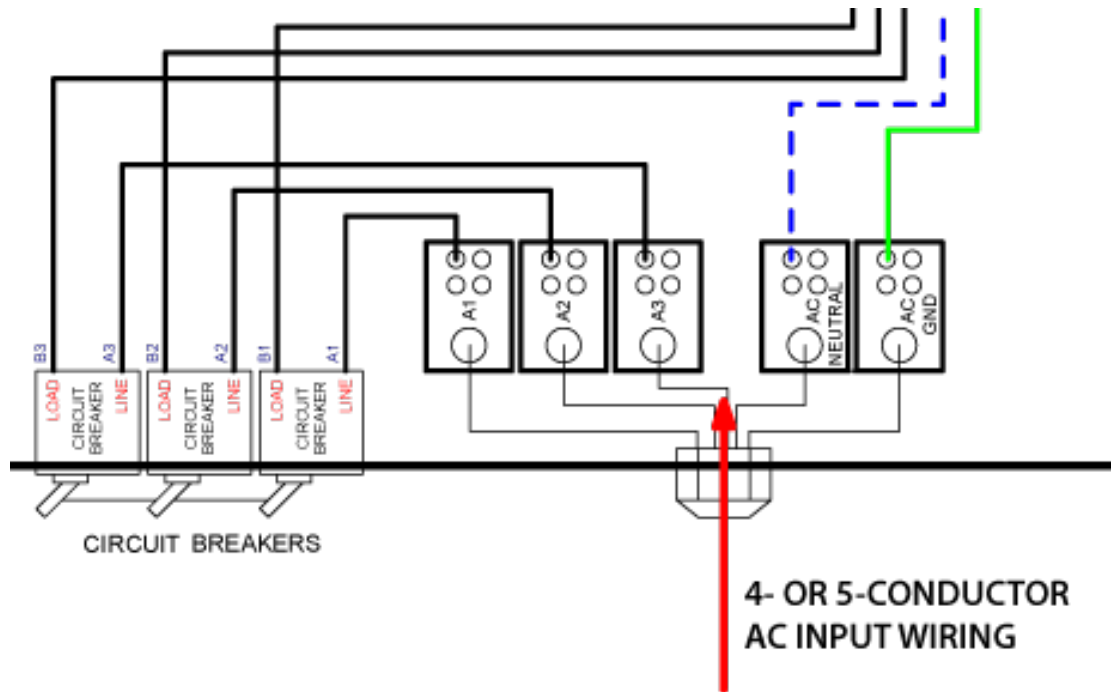

Figure 2.13 – Three-Phase AC Mains Wiring

2.6 Startup Procedure

Complete the following steps to power up the 7800 Series system.

- A. Depress the front panel SYSTEM POWER switch to turn the 7800 Series cabinet ON.
- B. When SYSTEM POWER is enabled, the unit will automatically begin the power-up sequence to activate the amplifier system. When the power-up sequence is complete for all ampli-

fier modules, the Ready and Run LEDs will be lit on all modules, and the amplifier will amplify the input signal. The LCD screen on the upper module will display the VPEAK/VRMS/IPEAK/IRMS meters (multi-display) (see **Figure 2.14**).

WARNING: If amplifier has been unused/inactive for 2 years or more, please startup connected to a low-voltage DC power supply. Start at 10% of the rated voltage and gradually increase to avoid damaging internal components.



Figure 2.14 – Amplifier LCD Screen when the system is enabled

3 Operation

3.1 System Controls and Connectors

This section describes the system-wide controls and connectors provided on your 7800 amplifier system. Refer to **Figure 3.1** for item locations.

In addition to the system controls and connectors, your 7800 system contains from two to four amplifier modules that provide additional status and control functions. Please see the following section, **“Amplifier Module Controls and Indicators,”** for more information.

System Power– This switch is located on the upper front of the 7800 series system cabinet and controls the AC power to the system. Press to enable power to the amplifier system. Press again to remove AC power from the amplifier system.

AC Breakers – This switch controls the power to the amplifier. Place in the ON position to energize the amplifier system. Switch to the OFF position to remove power from the system.

AC Supply Inlet – This cable strain relief inlet port allows AC power cable to be routed to the AC supply connectors.

3.2 Amplifier Module Controls and Indicators

Your 7800 system contains between two and four amplifier modules configured to provide high-current output. These modules are interlocked together, with one Master amplifier controlling the operation of all of the amplifier modules in the system.

With the exception of the power/breaker switch, a control operated on the Master amplifier module will perform that action on all of the amplifier modules in the system.

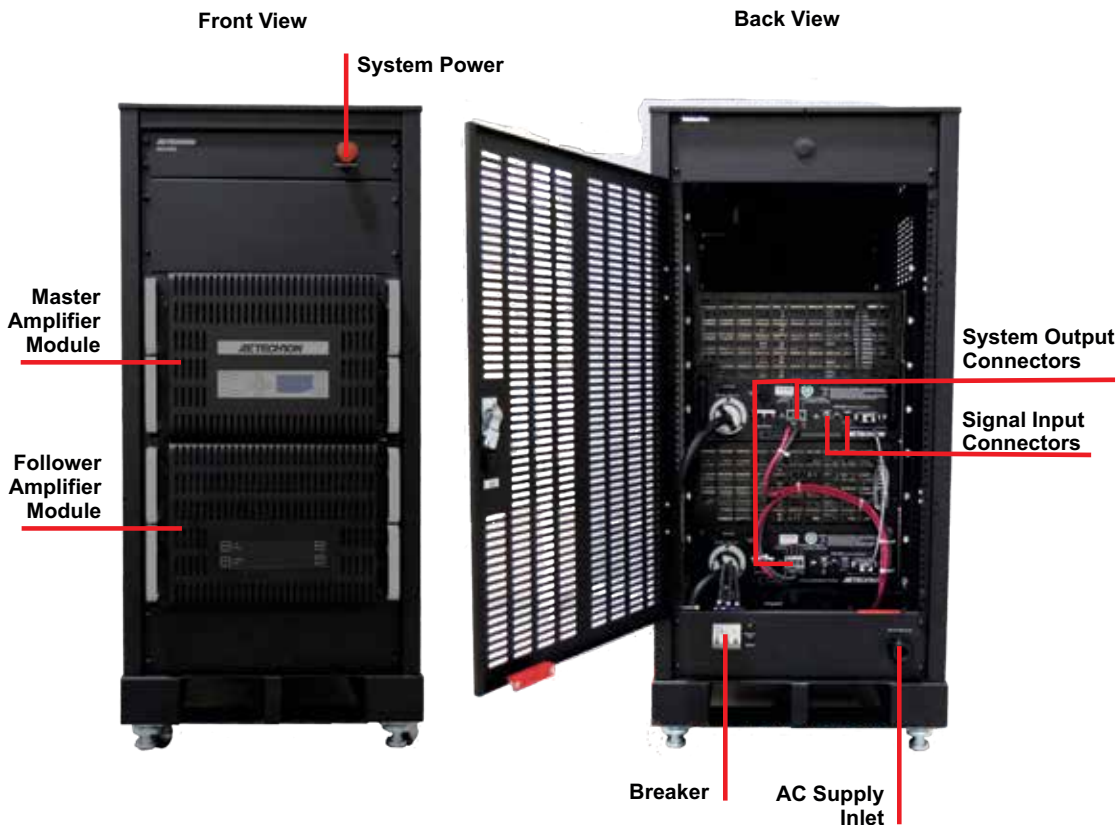

Figure 3.1 – 7800 Series System Item Locations

The following sections describe the controls and indicators found on the 7800 Series amplifier modules.

Refer to **Figure 3.2** for item locations.

3.2.1 Front-Panel Controls & Indicators

This section provides an overview of Front-Panel controls found on the 7800 amplifier modules.

Input Buttons

Three Push Buttons on the amplifier front panel control basic operation of the amplifier.

Enable – When the system has been placed in Standby mode, pressing the Enable button on the amplifier module that was used to place the system in Standby will release the system from Standby status and return all of the amplifier modules to Run mode. Note that the amplifier module control-

ling the Standby status will have the Standby and Stop LEDs lit, while all other modules will have the Ready and Standby LEDs lit. Pressing the Enable button on an amplifier module other than the module used to place the system in Standby mode will NOT return the system to Run mode. When the system is placed in Run mode, the high-voltage transformers will be energized and the system will amplify the input signal.

Stop – Pressing the Stop button on any amplifier module in the system will place that module in Stop mode and all other amplifier modules in Standby mode. When an amplifier module is in Stop or Standby mode, the low-voltage transformer is energized but the high-voltage transformers are not.

Reset – Pressing the Reset button on the ampli-

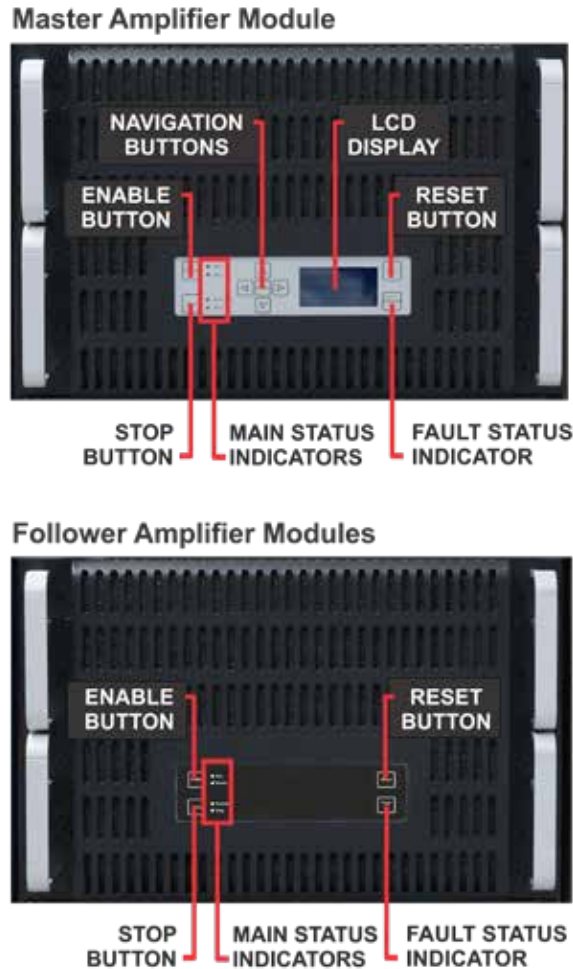

Figure 3.2 – 7800 Series Amplifier Modules Item Locations

fier module reporting the fault condition will clear the condition and return all amplifiers modules to Run or Stop mode, depending on the status mode the system was in when the fault condition occurred. Pressing the Reset button on other amplifier modules in the system will NOT clear the fault condition.

Multi-Function LCD Display

Master Amplifier Module only.

The multi-function LCD display provides peak and RMS values for voltage and current measured directly from the amplifier output. If the amplifier experiences a fault condition, the LCD display will automatically display details of the fault condition and prescribed corrective actions.

On startup, the LCD Display will provide readings for all four measurements: Volts peak, Volts RMS, Current peak, and Current RMS. Use the Navigation buttons to scoll to other available displays, such as peak voltage and current only, RMS voltage and current only, or other combinations.

Navigation Buttons

Master Amplifier Module only.

The Navigation buttons provide four arrow keys to allow navigation through the different voltage and current measurement functions on the LCD display screen.

NOTE: The Enter button has been provided for future expansion and has no function at this time.

Main Status Indicators

Four Main Status indicators are located on the amplifier module’s front-panel. These LEDs monitor the internal conditions of the module and indicate the current state of operation. The chart in **Figure 3.3** details the operational modes indicated by the Main Status indicators.

In systems with multiple amplifier modules, the Main Status indicators on each module are used to determine the operational status of that module and are also evaluated along with the statuses of the other amplifier modules to determine the system status and the action required to return the system to a running condition. See **Figure 3.4**.

Figure 3.3 – Main Status Indicators for Single Amplifiers

● Indicator is lit ● Indicator is lit ● Indicator is lit ○ Indicator may be lit

Main Status Indicators	State of Operation	Action Needed to Return to Run Mode
<ul style="list-style-type: none"> ● Run ● Ready ○ Standby ○ Stop 	<p>Run mode: The amplifier’s high-voltage transformers are energized and the unit will amplify the input signal. Run mode is initiated by: (1) the Enable push button when the amplifier is in Standby mode, or (2) when the amplifier powers up..</p>	N/A
<ul style="list-style-type: none"> ○ Run ○ Ready ● Standby ○ Stop 	<p>Standby mode: Standby mode indicates that the amplifier is functioning properly and all Fault Status modes are clear, but it is being held in Standby by an external condition. The amplifier will enter Standby mode briefly after powering up, and then will move automatically into Run mode. In Standby mode, the amplifier’s low-voltage transformer is energized but the high-voltage transformers are not.</p>	If the amplifier remains in Standby mode, and it is not part of a multi-amp system, the amplifier module may require servicing. Please contact AE Techron Technical Support.
<ul style="list-style-type: none"> ○ Run ○ Ready ● Standby ● Stop 	<p>Stop mode: When the Stop button on the amplifier front panel is pressed, the amplifier will enter Stop mode. In Stop mode, the amplifier’s low-voltage transformer is energized but the high-voltage transformers are not.</p>	To release the amplifier from Stop mode, press the Enable button.

Figure 3.4 – Main Status Indicators for Multi-Amplifier Systems

● ● ● Indicator is lit ● Indicator is not lit ○ Indicator may be lit

Main Status of One or More Amps in the System	Main Status of Other Amps in the System	State of Operation	Action Needed to Return to Run Mode
<ul style="list-style-type: none"> ● Run ● Ready ● Standby ● Stop 	<ul style="list-style-type: none"> ● Run ● Ready ● Standby ● Stop 	<p>Run mode: All of the amplifiers in the system are in Run mode. The amplifiers' high-voltage transformers are energized and the system will amplify the input signal.</p>	N/A
<ul style="list-style-type: none"> ● Run ● Ready ● Standby ● Stop 	<ul style="list-style-type: none"> ● Run ● Ready ● Standby ● Stop 	<p>System Not Ready: If one or more of the amplifiers has no LEDs lit, the amplifier has no power or has not been turned on, and the other amplifiers in the system will be held in Standby mode. In Standby mode, the amplifier's low-voltage transformer is energized but the high-voltage transformers are not.</p>	Make sure all amplifiers have AC power and have been turned on. When all amplifiers attain Standby status, all amplifiers in the system will simultaneously be placed in Run mode.
<ul style="list-style-type: none"> ● Run ● Ready ● Standby ● Stop 	<ul style="list-style-type: none"> ● Run ● Ready ● Standby ● Stop 	<p>Stop mode: When the Stop button on any amplifier in the system is pressed, that amplifier will enter Stop mode and all other amplifiers will enter Standby mode. In Stop mode, the amplifier's low-voltage transformer is energized but the high-voltage transformers are not.</p>	To release the system from Stop mode, press the Enable button on the amplifier displaying the Stop mode status.

Figure 3.5 – Fault Status Indicators for Single Amplifiers

● ● ● Indicator is lit ● Indicator is not lit ○ Indicator may be lit

Main Status Indicators	Fault Status Reported on LCD Display	State of Operation	Action Needed to Clear Fault Condition and Return to Run Mode
<ul style="list-style-type: none"> ● Run ● Ready ● Standby ● Stop 	WARNING! OUTPUT DEVICE FAULT	<p>Output Device Fault: This indicates that an Output Fault condition has occurred and the amplifier has been placed in Standby mode. The Fault indicator will light under two conditions: 1) High-frequency oscillation is causing high shoot-through current; or 2) An output transistor has shorted, causing the output fault condition.</p>	This fault condition cannot be cleared using the front-panel Reset button. See the Troubleshooting section for more information on diagnosing and clearing this fault condition.
<ul style="list-style-type: none"> ● Run ● Ready ● Standby ● Stop 	WARNING! OVERLOAD	<p>Overload: This indicates that the output of the amplifier could not follow the input signal due to voltage or current limits.</p>	To remedy the Overload fault, turn down the level of the input signal until the Fault indicator turns off.
<ul style="list-style-type: none"> ● Run ● Ready ● Standby ● Stop 	WARNING! OVERTEMP	<p>Overtemp: The amplifier monitors the temperature inside the high-voltage transformers, low-voltage transformer and in the output stage heat sinks. The Fault indicator will light and the amplifier will be placed in Standby mode when the temperature sensors detect a condition that would damage the amplifier. If the Overtemp pulse is extremely short, as in the case of defective wiring or switches, the Fault LED may be lit too briefly to observe.</p>	To reset after an Over Temp fault has occurred, make sure the amplifier fans in all amplifiers are running, and then remove the input signal from the system. Allow the fans to run for about 5 minutes until the system automatically returns to Run mode. Please see the "Troubleshooting" section for information on correcting the cause of an Over Temp fault condition.

Figure 3.5 – Fault Status Indicators for Single Amplifiers (continued)

Main Status Indicators	Fault Status Reported on LCD Display	State of Operation	Action Needed to Clear Fault Condition and Return to Run Mode
<ul style="list-style-type: none"> ● Run ● Ready ● Standby ● Stop 	<p>WARNING! OVERVOLTAGE</p>	<p>Overvoltage: This indicates that the AC mains voltage is more than +10% of nominal. The amplifier will be forced to Standby when an Overvoltage condition occurs. When the Overvoltage condition is cleared, the amplifier will automatically return to Run mode.</p>	<p>To clear an Overvoltage fault condition, the AC mains must be brought down to the nominal value. If the amplifier does not return to Run mode when the Overvoltage condition has cleared, the amplifier may require servicing. Please see the Troubleshooting section for more information.</p>

Figure 3.6 – Fault Status Indicators for Multi-Amplifier Systems

● ● ● Indicator is lit ● Indicator is not lit ○ Indicator may be lit

One or More Amps in System		Main Status Indicators of Other Amps in System	State of Operation	Action Needed to Clear Fault Condition and Return to Run Mode
Main Status Indicators	Fault Status Reported on LCD Display			
<ul style="list-style-type: none"> ● Run ● Ready ● Standby ● Stop 	<p>WARNING! OUTPUT DEVICE FAULT</p>	<ul style="list-style-type: none"> ● Run ● Ready ● Standby ● Stop 	<p>Output Device Fault status: This indicates that an Output Fault condition has occurred in the amplifier displaying the Fault status, and the system has been placed in Standby mode. The Fault indicator will light under two conditions: 1) High-frequency oscillation is causing high shoot-through current; or 2) An output transistor has shorted, causing the output fault condition.</p>	<p>This fault condition cannot be cleared using the front-panel Reset button. See the Troubleshooting section for more information on diagnosing and clearing this fault condition.</p>
<ul style="list-style-type: none"> ● Run ● Ready ○ Standby ● Stop 	<p>WARNING! OVERLOAD</p>	<ul style="list-style-type: none"> ● Run ○ Ready ○ Standby ● Stop 	<p>Overload status: This indicates that the output of the system could not follow the input signal due to voltage or current limits.</p>	<p>To remedy the Overload fault, turn down the level of the input signal until the Overload indicator turns off.</p>
<ul style="list-style-type: none"> ● Run ● Ready ● Standby ● Stop 	<p>WARNING! OVERTEMP</p>	<ul style="list-style-type: none"> ● Run ● Ready ● Standby ● Stop 	<p>Overtemp status: Each amplifier in the system monitors the temperature inside the high-voltage transformers, low-voltage transformer and in the output stage heat sinks. The Overtemp indicator will light and the system will be placed in Standby mode when the temperature sensors detect a condition that would damage the amplifier system. If the Overtemp pulse is extremely short, as in the case of defective wiring or switches, the Fault LED may be lit too briefly to observe.</p>	<p>To reset after an Overtemp fault has occurred, make sure the amplifier fans in all amplifiers are running, and then remove the input signal from the system. Allow the fans to run for about 5 minutes until the system automatically returns to Run mode. Please see the Troubleshooting section for information on correcting the cause of an Overtemp fault condition.</p>

Figure 3.6 – Fault Status Indicators for Multi-Amplifier Systems (continued)

One or More Amps in System		Main Status Indicators of Other Amps in System	State of Operation	Action Needed to Clear Fault Condition and Return to Run Mode
Main Status Indicators	Fault Status Reported on LCD Display			
<ul style="list-style-type: none"> ● Run ● Ready ● Standby ● Stop 	<p>WARNING! OVERVOLTAGE</p>	<ul style="list-style-type: none"> ● Run ● Ready ● Standby ● Stop 	<p>Overvoltage status: This indicates that the AC mains voltage is more than +10% of nominal. All amplifiers in the system will be forced to Standby when an Overvoltage condition occurs. When the Overvoltage condition is cleared, the system will automatically return to Run mode.</p>	<p>To clear an Overvoltage fault condition, the AC mains must be brought down to the nominal value. If the system does not return to Run mode when the Overvoltage condition has cleared, one or more amplifiers may require servicing. Please see the Troubleshooting section for more information.</p>

Fault Status Indicator

The Fault Status indicator is located on the amplifier module’s front panel. This LED monitors the internal conditions of the module and will illuminate when a fault condition occurs. Depending on the fault condition, the 7800 system may be placed in Standby mode when a fault condition occurs. Refer to the chart in **Figure 3.5** to determine the fault condition being indicated and the action required to clear the fault condition.

In systems with multiple amplifier modules, the Fault Status indicators on each module are used to determine the operational status of that module. When a fault condition occurs on any module in

the system, the system may be placed in Standby mode. Typically, the system can be released from Standby mode by pressing the Reset button on the amplifier module displaying the Fault status. Refer to the chart in **Figure 3.6** to determine the fault condition being indicated and the action required to clear the fault condition and return the system to a running condition.

3.3 Back-Panel Controls and Connectors

This section provides an overview of Back-Panel controls and connectors found on the 7800 series amplifier modules. Please refer to **Figure 3.7** for visual locations.

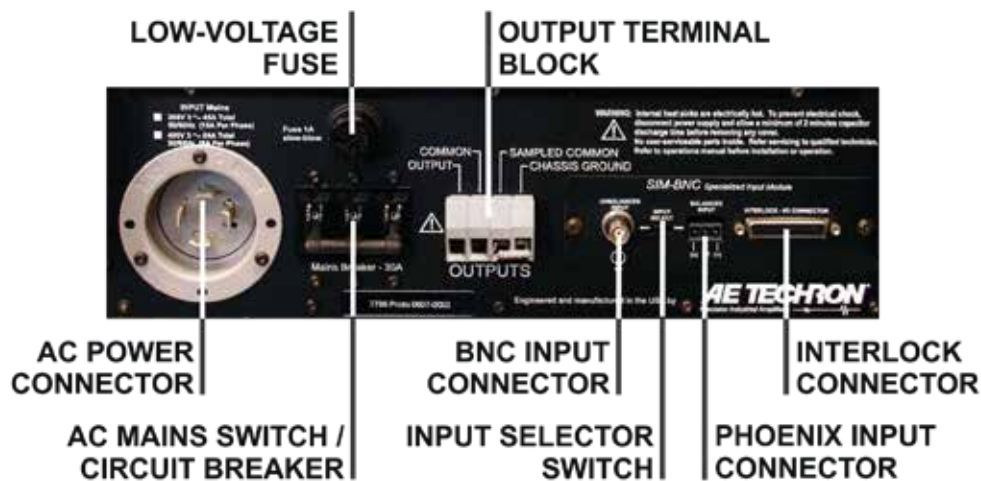

Figure 3.7 – Back Panel Controls and Connectors

AC Power Connector - This is a NEMA style twist lock, 4 pin (208V) or 5-pin (400V), three-phase connector.

Low-Voltage Fuse - This is a 1A slow blow type 600-volt rated fuse.

AC Mains Switch/Circuit Breaker - This dual function power switch and circuit breaker opens all legs of the AC mains.

Output Terminal Block - Connect output lines from the load to this 4-terminal block on the Master amplifier module. The connector accepts up to #4 AWG wire. If operating in Controlled Current mode, use the OUTPUT terminal and the SAMPLED COMMON terminal only.

BNC Input Connector - This input option provides a standard unbalanced input.

Input Selector Switch - This switch selects which input connector is active, the BNC or Weco.

Weco Input Connector - This input option provides a balanced input.

Interlock Connector - This 25-pin, D-sub connector is used for interlocking amplifier modules to combine operating functions in a multi-amp system. It can also be used for remote control and monitoring applications (see the **Applications** section for more information).

4 Advanced Configuration

The 7800 series amplifier was designed to offer exceptional power and versatility in operation. You can choose from a range of field-configurable options, including:

- Select DC-coupled or AC-coupled operation.
- Select Controlled-Current or Controlled-Voltage modes of operation.
- Enable a 50-kHz low-pass filter.
- Change the maximum amplifier gain from 20:1 to 6:1.
- Configure the amplifier to enter Standby on startup
- Configure the amplifier to enter Standby when an overload condition occurs.
- Configure the bi-level power supply for use in high voltage applications, high current applications, or for applications requiring mid-level amounts of both voltage and current.

Configurations settings are made using the eight DIP switches located on the amplifier’s main circuit board, using shunts across jumper pins located on the main circuit board, or by plug and switch settings on the amplifier’s power supply board. These controls can be used to alter the amplifier operation from the factory defaults.

4.1 Factory Defaults

Your 7800 series amplifier has been configured to operate to the following factory defaults:

- DC-coupled operation
- Controlled-Voltage mode
- CC1 Compensation network
- Low-pass filter disabled
- Power supply configured for mid-level operation
- Power-Up into Ready mode
- Standby Mode on Overload disabled

If you need to make changes to your amplifier’s configuration, please follow the instructions contained in this chapter for accessing the main board DIP switches and jumpers, and the power supply board settings..

The main and power supply boards can be accessed by removing the amplifier module’s front panel. To remove the front panel for each module, complete the steps detailed in the following section.

	WARNING
<p>Do not attempt to access the Main Board while the amplifier is running. Turn the amplifier off and disconnect the AC Mains before removing the amplifier front panel.</p>	

	CAUTION
<p>After turning the amplifier off, let the unit sit for 3-5 minutes before removing the front panel. This will allow the electrical charge in the Power Supply capacitors to discharge.</p>	

4.2 Accessing the Main Board

The amplifier Main Board can be accessed by removing the module’s front panel.

IMPORTANT: Before removing the front panel, make sure the amplifier system is turned off for at least 3-5 minutes and the AC mains are disconnected.

Tool Required

Torx T15 driver

Procedure

1. Turn the power to the amplifier system “OFF”.
2. Remove the four hex-head screws, located along the left and right edges of the amplifier module’s front panel using a Torx T15 driver.
3. Remove the front cover by pulling straight towards you.

4.3 Configuration Settings Controlled by DIP Switches

The 7800 series provides eight DIP switches located on the main board of each amplifier module. Most configuration settings can be made using

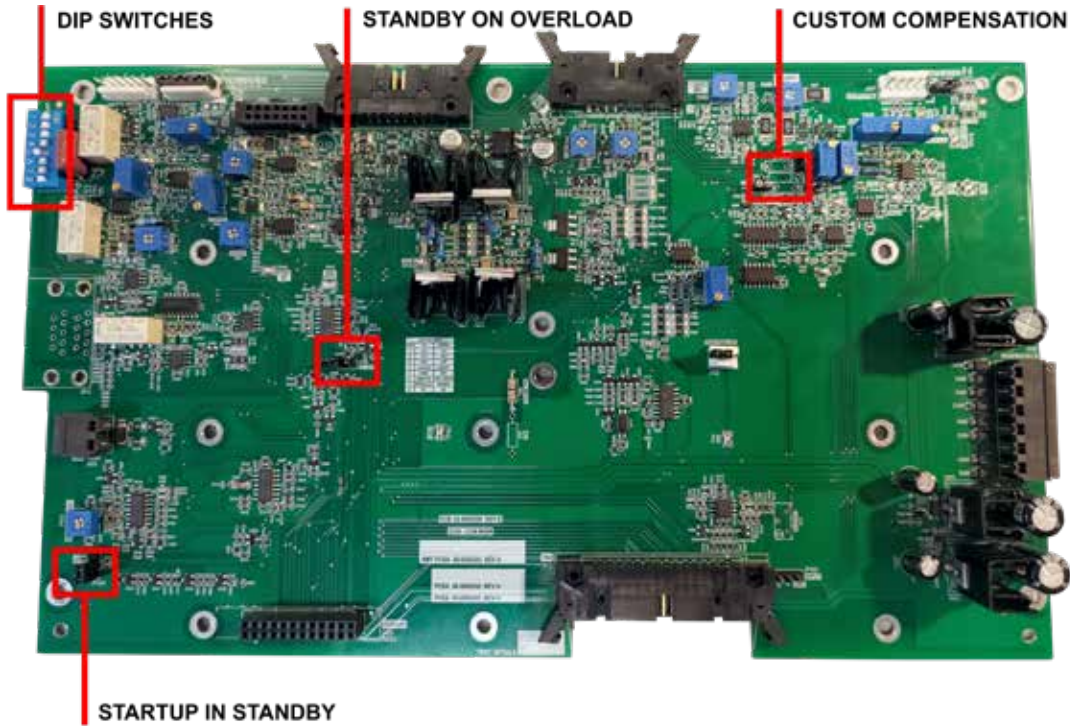

Figure 4.1 – Main Board Configuration Locations

		1 2 3 4 5 6 7 8			
	DIP SWITCH SETTINGS		UP	DOWN	
Controlled-voltage or controlled-current operation	1	OPERATION (CV / CC)	CV	CC	
	2	COMPENSATION (CC1 / CC2)	CC1	CC2	Compensation network (for controlled-current operation)
Enable 50 kHz low-pass filter	3	LOW PASS FILTER	OFF	ON	
	4	GAIN (20 / 6)	20	6	Gain selection (20 / 6)
Enable electronic gain matching (for parallel multi-amp operation)	5	ELECTRONIC GAIN MATCHING	ON	OFF	
	6	MASTER / FOLLOWER	MASTER	FOLLOWER	Multi-amp configuration
Low (line-level) input or high input (up to 180V)	7	VOLTAGE INPUT (LOW / HIGH)	LOW	HIGH	
	8	DC / AC COUPLING	DC	AC	DC enable or DC block
		RED = FACTORY DEFAULT			

Figure 4.2 – DIP Switch Settings and Descriptions

the DIP switches on the main board on the Master amplifier module ONLY.

Please refer to **Figure 4.1** for main board DIP switch locations. See **Figure 4.2** for DIP switch settings and descriptions.

SW#1: Operation (CV/CC)

When the Operation DIP switch on the Master amplifier module is in the UP position (default), the system will operate in Controlled-Voltage mode, and the system’s output voltage will be controlled

by its input voltage signal. When this switch is in the DOWN position, the system will operate in Controlled-Current mode, and the system’s output current will be controlled by its input voltage signal.

IMPORTANT: Controlled-Current operation requires the use of a compensation network, and the 7800 series’ default compensation network may not be suitable for your application. For more information on Controlled-Current operation, including how to determine and configure a custom compensation network, see the **Applications** section.

	<h2 style="margin: 0;">CAUTION</h2>
<p>In Controlled-Current Mode, the load is part of the amplifier circuit, and the relationship of the load to the amplifier is critical. For proper and safe operation in Controlled-Current mode, you must observe the following guidelines:</p> <ol style="list-style-type: none"> 1. Properly attach a load before operating the amplifier. 2. DO NOT use a blocking capacitor. The load must have a DC path. 3. Never leave the load open. If you feel the load must be fused, which could lead to a potential open circuit, please contact AE Techron Technical Support. 4. Make sure the load has some inductive component. 5. Provide appropriate compensation for the load. 6. If oscillation occurs, turn off the amplifier immediately. <p>Failure to follow these guidelines may result in damage to the amplifier or load.</p>	

SW#2: Compensation (CC1/CC2)

When a 7800 series amplifier is used in Controlled-Current mode, the current control loop is tuned with an RC network on the Master amplifier module. Place the Compensation DIP switch in the **Up** position (default) to enable the factory-installed RC network (**CC1**). This network consists of a 68.1 kΩ resistor in series with a 47 nF capacitor. Place the DIP switch in the **Down** position to select **CC2** network. This network is unpopulated, but can be populated with a custom compensation network to fit your requirements. For more information on Controlled-Current operation and installing a custom compensation network, see the *“Applications”* section of this manual.

SW#3: Low-Pass Filter

The Low Pass Filter function inserts a 50 kHz (3-dB down) low-pass filter at the amplifier input to ensure that signals above 50 kHz are not amplified.

Place the Low-Pass Filter DIP switch on the Master amplifier module in the **Up** position (default) to disable the low-pass filter. To enable the low-pass filter, place the DIP switch in the **Down** position.

SW#4: Gain (20/6)

When the Gain DIP switch on the Master amplifier module is in the **Up** position (default), the amplifier’s maximum gain will be 20:1. Placing the DIP switch in the **Down** position will change the amplifier’s maximum gain to 6:1.

SW#5: Electronic Gain Matching

NOTE: Do not change the setting of this DIP switch. It is required for proper functioning of the amplifier system.

The Electronic Gain Matching function serves to minimize circulating currents when multiple amplifiers are used in a parallel configuration. When enabled, the Electronic Gain Matching function progressively increases impedance from the voltage gain as current increases, up to a maximum 0.10-ohm increase. This allows the amplifiers to operate in parallel without the use of separate ballast resistors in multi-amp applications up to 20 kHz.

When this switch is in the **Down** position, Electronic Gain Matching is disabled. When the Electronic Gain Matching DIP switch is in the **Up** position, the Electronic Gain Matching function is enabled.

SW#6: Master/Follower

NOTE: Do not change the setting of this DIP switch. It is required for proper functioning of the amplifier system.

When the Master/Follower DIP switch is in the **Up** position (default), the amplifier will function as a stand-alone amplifier or as a Master amplifier in a multi-amp system. When this switch is in the **Down** position, the amplifier will function as a Follower amplifier in a multi-amp system.

SW#7: Voltage Input (Low/High)

NOTE: Do not change the setting of this DIP switch. It is required for proper functioning of the amplifier system.

When the Voltage Input DIP switch is in the **Up** position, the amplifier can be configured for use with alternate multi-amp connectors in a multi-amp system (not available on 7800 series models). When this switch is in the **Down** position, the amplifier can be configured for use with standard multi-amp connectors in a multi-amp system.

SW#8: DC/AC Coupling

When the DC/AC Coupling DIP switch is in the **Up** position (default), the amplifier can receive and amplify both DC and AC signal. When this switch

is in the **Down** position on the Master amplifier module, a 2-Hz high-pass filter on the inputs prevents the transmission of DC signal.

4.4 Configuration Settings Controlled by Jumpers

The following settings can be made via jumper settings on the Main Board. Please refer to **Figure 4.1** for main board jumper locations.

Custom Compensation Network

When the 7800 series amplifier is used in Controlled-Current mode, the current control loop is tuned with an RC network. The factory default network (CC1) provides 68.1k ohm resistance and 47 nF capacitance. If this default network is not adequate for your application and load, CC2 can be used to install a custom RC network on the Master amplifier module’s main board.

For information on installing a custom RC network, please see the topic “**Controlled Current Operation**” in the **Applications** section of this manual.

Enable/Stop on Power-up

The 7800 series amplifier will power-up to Run Mode when a shunt is placed across pins 1 and 2 on the Enable/Stop jumper (default setting). See **Figure 4.3**. To cause the 7800 series amplifier to enter Standby (Stop Mode) on power-up, place the

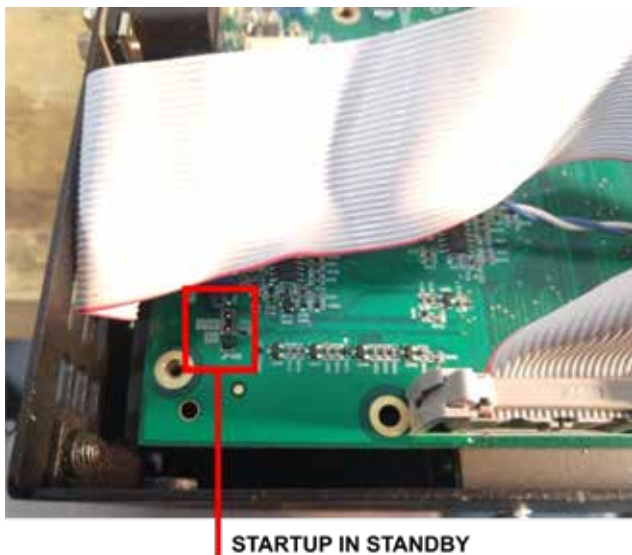

Figure 4.3 – Enable/Stop on Power-up Configuration

shunt across pins 2 and 3 on the main board of the Master amplifier module.

Standby on Overload

The 7800 series amplifier’s IOC (Input/Output Comparator) Distortion Alert circuit continuously compares the waveforms observed at the amplifier input and output. When a distortion between the two waveforms of more than 0.5% occurs, the IOC circuit will activate, and the Overload LED will light, but the amplifier will continue to operate. To configure the amplifier to move to Standby (Fault mode) when the IOC circuit is activated, locate the Overload Latch (see **Figure 4.4**) on the main board of the Master amplifier module and place a shunt across the two pins of the jumper.

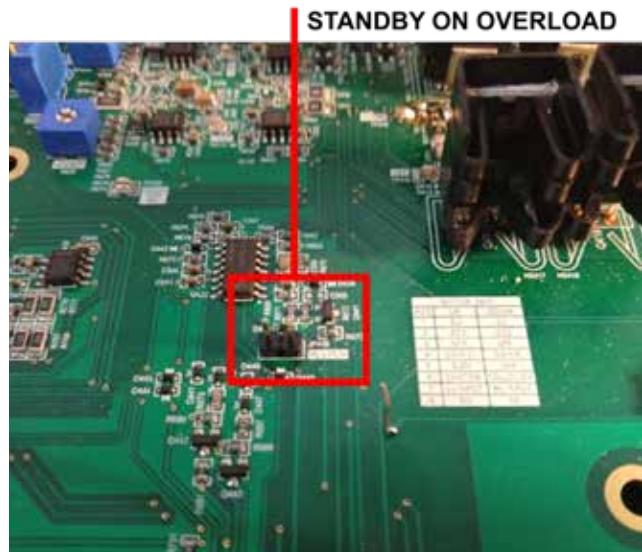

Figure 4.4 – Configure for Standby (Fault Mode) on Overload

4.5 Adjusting the Bi-Level Power Supply Switch

NOTE: Before changing the Bi-Level Power Supply setting, please contact AE Techron Technical Support for instructions on the proper settings to use for your application.

The amplifier system offers three Bi-Level switch settings: Automatic, High, or Low. The user can select between settings via a switch on the Power Supply Board for each amplifier module. The Power Supply Board is a horizontal board located

below the main and display boards. To access the Bi-Level Power Supply Switch, complete the following steps to remove the front panel and access the bi-level power supply switch.

IMPORTANT: Before removing the Front Panel of any amplifier module, make sure the amplifier system is turned off for at least 3-5 minutes and the AC mains are disconnected.

1. Turn the power to the amplifier system “OFF”.
2. Remove the four hex-head screws, located along the left and right edges of the amplifier module front panel using a Torx T15 driver.
3. Remove the front cover by pulling straight towards you.
4. Locate the Bi-level Power Supply Switch as shown in **Figure 4.5**.
5. **Adjust the switch setting based on your operating requirements, as described in the following:**
 - **AUTO** (left position) – power supply will switch

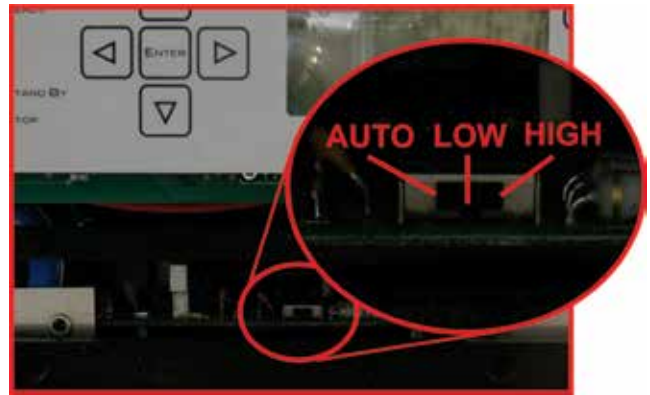

Figure 4.5 – Bi-Level Power Switch Location

depending on voltage requirements (factory-default setting).

- **LOCKED LOW** (center position) – power supply will remain in low-voltage mode.
- **LOCKED HIGH** (right position) – power supply will remain in high-voltage mode.

5 Applications

5.1 Remote Status and Control using the SIM Interlock I/O Connector

The procedures outlined in this section assume competence on the part of the reader in terms of amplifier systems, electronic components, and good electronic safety and working practices.

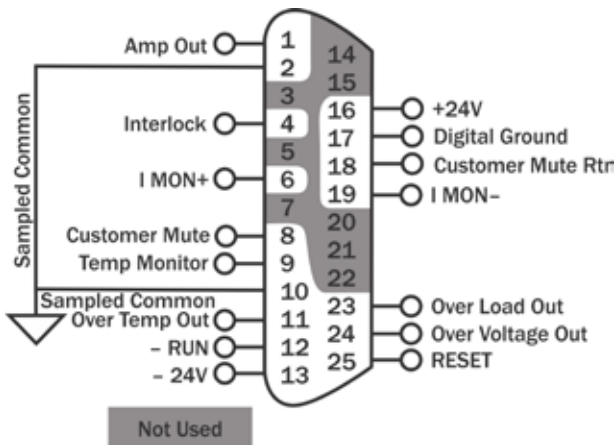

Figure 5.1 – Remote Status and Control Pinouts on 25-pin D-Sub Connector (SIM card)

NOTE: Before configuring your 7800 series system using these remote configurations, please contact AE Techron Technical Support for the proper settings to use for your application.

AE Techron 7800 series amplifiers come with a SIM-BNC input module that also contains a female, 25-pin D-Sub connector. This connector can be used to provide remote control and monitoring of the amplifier.

The information provided here will instruct you in the wiring of several control and status applications including:

- Remote Run / Standby
- Amplifier status: Run, Over-temperature, Overload, Overvoltage; and Reset after Overload error
- Remote Enable/Standby
- Customer mute
- Current monitor
- Temperature monitor

Figure 5.1 maps the pins used for these applications.

For a detailed chart of all DB-25 pinouts, see “Appendix 1.”

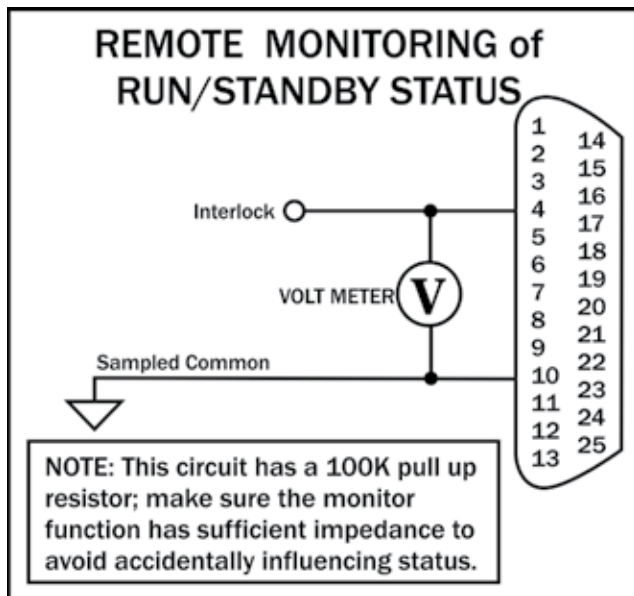

Figure 5.2 – Remote Run/Standby Monitor

5.1.1 Remote Run/Standby Status Monitor

Using the SIM-BNC Interlock connector located on the back panel of the Master amplifier module, you can remotely monitor the Run/Standby status of the amplifier.

Remote Run/Standby Status

Purpose: Use a voltage meter to monitor the status of the amplifier to determine if the amplifier is in a “Run” or “Standby” state.

Method: Connect a voltage meter to monitor the circuit voltage. Connect across PIN 4 (Interlock) and PIN 10 (Sampled Common).

When the voltage meter reads greater than 10V, the amplifier is in the Run state; when the meter reads less than 10V, the amplifier is in the Standby state. See Figure 5.2.

Signal Type: DC

Level when Asserted: >10 V

Level when Deasserted: <10 V

IMPORTANT: This circuit has a 100K pull-up resistor. Make sure the monitor function has sufficient impedance to avoid accidentally influencing status.

5.1.2 Remote Amplifier Status and Reset

The SIM Interlock I/O Connector can be used to create a circuit to monitor remotely one or more amplifier conditions, including Run status, Over-temperature, Overload and Overvoltage. The circuit can also be constructed to allow remote reset of the amplifier system when it is forced to Standby due to Overload conditions.

Use a male, 25-pin D-Sub connector and high-quality wire to build the circuit. **Figure 5.3** schematic details the circuit and components required for all status and reset functions.

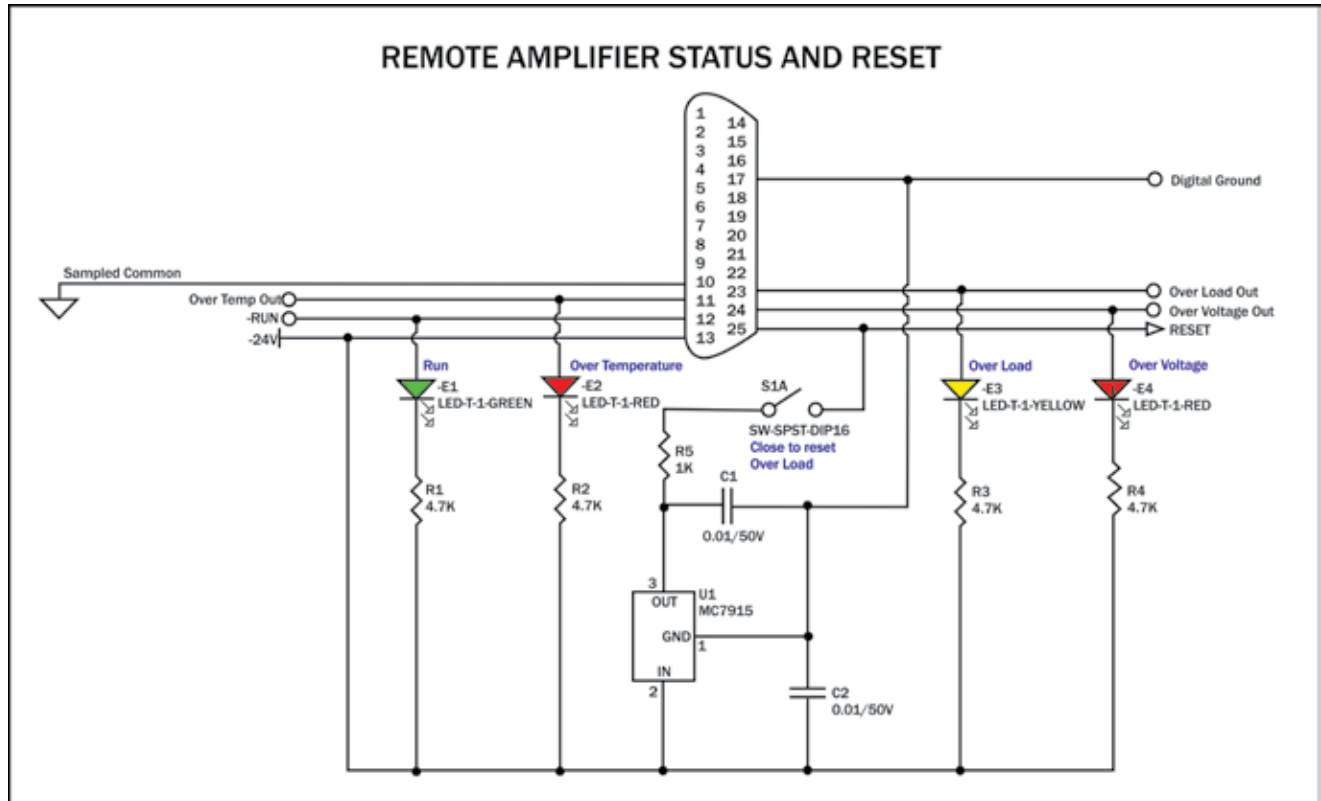

Figure 5.3 – Remote Status and Reset Schematic

Remote Signal of Over Temperature Condition

Purpose: LED, when lit, signals Over Temperature condition.

Method: Use a 6mA series resistor of 4.02 Kohm for LED or OPTO, tie OverTemp Out (PIN 11) to -24V source (PIN 13).

Signal Type: DC

Level when Asserted: -24V

Level when Deasserted: 0V

Note: When amp is normal, this pin is pulled to -24V through a 47.5K-ohm resistor; when amp is in Overtemp state, transistor Q37 turns on and sources chassis ground as an output. Do not exceed 20 milliamps.

An Overtemp condition will force the amp to Standby. The amplifier will automatically move to Run when temperature cools to operating levels.

Remote Signal of Run Condition

Purpose: LED, when lit, signals Run state.

Method: Use a 6mA series resistor of 4.02K-ohm for LED or OPTO, tie Run (PIN 12) to –24V source (PIN 13).

Signal Type: DC

Level when Asserted: –24V

Level when Deasserted: 0V

Remote Signal of Overload Condition

Purpose: LED, when lit, signals Overload condition.

Method: Use a 6mA series resistor of 4.02K-ohm for LED or OPTO, tie OverLoad Out (PIN 23) to –24V source (PIN 13).

Signal Type: DC

Level when Asserted: –24V

Level when Deasserted: 0V

Note: When amp is normal, this pin is pulled to –24V through a 47.5K-ohm resistor; when amp is in Overload state, transistor Q36 turns on and sources chassis ground as an output. Do not exceed 20 milliamps.

An Overload condition will not place the amplifier in Standby when operating with the factory default settings. In order to clear the fault condition, reduce the input levels until the Fault LED turns off. However, if the Standby Mode on Overload option is set, an Overload condition will force amp to Standby. To return the amplifier to Run mode, reduce the input signal level, then trigger a Reset command using the front-panel Reset button or a remote amplifier Reset command.

Remote Signal of OverVoltage Condition

Purpose: LED, when lit, signals Overvoltage condition.

Method: Use a 6mA series resistor of 4.02K-ohm for LED or OPTO, tie OverVoltage Out (PIN 24) to –24V source (PIN 13).

Signal Type: DC

Level when Asserted: –24V

Level when Deasserted: 0V

Note: When amp is normal, this pin is pulled to –24V through a 47.5K-ohm resistor; when amp is in Overvoltage state, transistor Q29 turns on and sources chassis ground as an output. Do not exceed 20 milliamps.

Reset from Standby

Purpose: Switch, when thrown, returns amp to Run condition after Overload conditions.

Method: Use a dry-contact switch, voltage regulator (MC7915), and two 0.01/50V capacitors; wire the circuit as shown (above). Assert 15V for at least 100 ms to clear the error condition.

Signal Type: DC

Level when Asserted: –15V

Level when Deasserted: 0V

Note: Tie to PIN 13 (–24V dc) and create a –15V dc source; <2mA required for reset. Connect the –15V dc source to PIN 25 (Reset) through a 1K buffer resistor to reset.

5.1.3 Remote Enable/Standby

Using the SIM-BNC Interlock connector located on the back panel of the Master amplifier module, you can remotely Enable the amplifier system and/or place the unit in Standby mode. See **Figure 5.4**.

Remote Enable/Standby

Purpose: Use a switch or optocoupler to remotely disable the amplifier and place it in Standby mode. Also, return the amplifier from Standby mode to the Run condition.

Method: Short PIN 4 of amplifier to Digital Ground (PIN 17) using a dry contact switch or optocoupler. In multi-amp applications, a switch can be used for Parallel systems, but an optocoupler must be used for Series systems. Multiple amplifiers (sharing the same Sampled Common power connections) can be simultaneously forced to Standby by daisy-chaining Interlock (PIN 4) across amps.

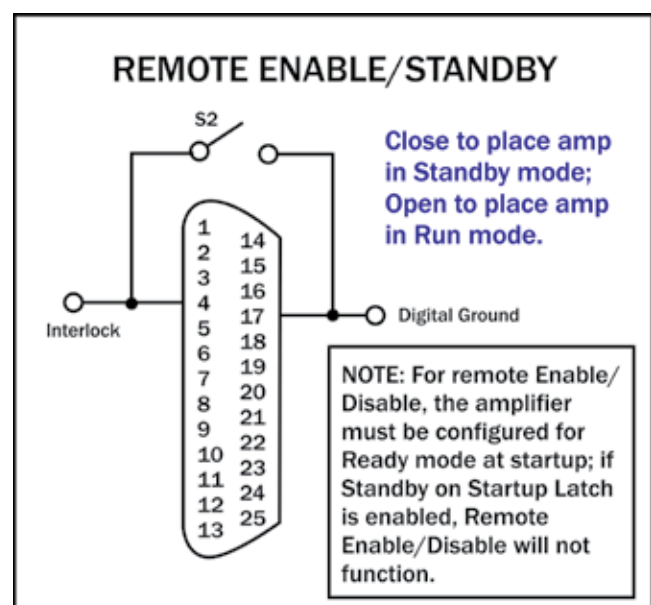

Figure 5.4 – Remote Enable/Standby

When Interlock (PIN 4) is shorted to Digital Ground (PIN 17), the amplifier is placed in Standby mode. When switch is open, the amplifier is released to the Run condition.

Signal Type: DC

Level when Asserted: 0 to 8 V

Level when Deasserted: 10 to 15 V

IMPORTANT: The amplifier must be configured for Ready mode at startup (factory default) or the Run button must be pressed at the amplifier module front panel at startup. The Remote Enable/Standby circuit will not function if the Startup to Standby Latch has been activated on the amplifier.

5.1.4 Remote Monitoring of Current

Using the SIM-BNC Interlock connector located on the back panel of the amplifier, you can remotely monitor current output.

Remote Monitoring of Current Output

Purpose: Use a voltage meter to monitor output current.

Method: Connect a voltage meter to monitor the output current being produced by the amplifier. Connect across PIN 6 (I MON+) and PIN 10 (Sampled Common). See **Figure 5.5**.

Signal Type: AC

Level when Asserted: 20A/V

Level when Deasserted: 0V

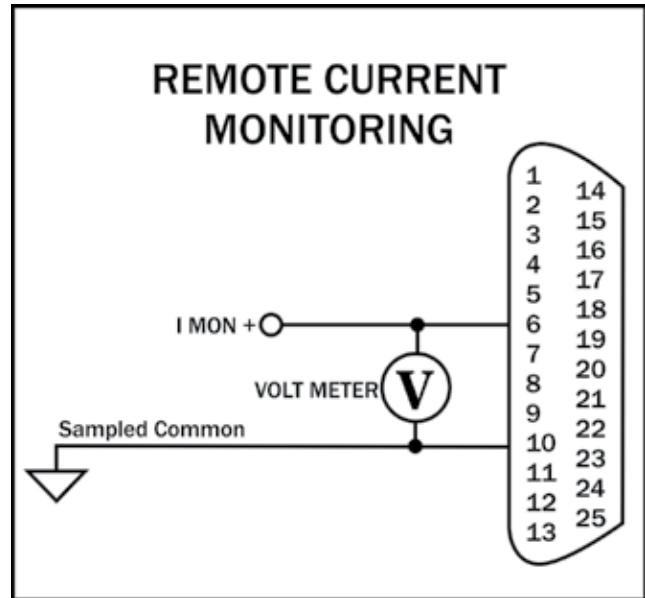

Figure 5.5 – Remote Current Monitoring

Remote Monitoring of Current Output - Alternate Method

Purpose: Use a voltage meter to monitor output current when output is not balanced.

Method: Connect a voltage meter to monitor the output current being produced by the amplifier. Connect across PIN 6 (IMON+) and PIN 19 (IMON-). See **Figure 5.6**.

Signal Type: AC

Level when Asserted: 10A/V

Level when Deasserted: 0V

CAUTION: To avoid ground loops, isolation from ground must be provided. Use of a differential probe is recommended.

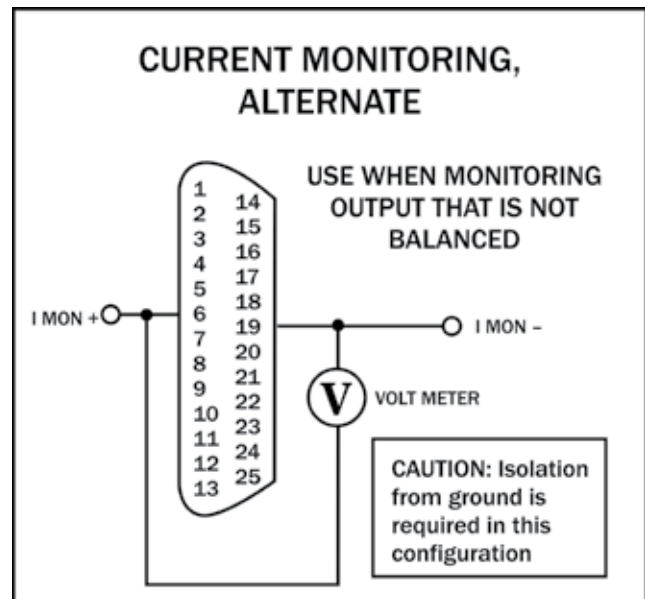

Figure 5.6 – Remote Current Monitoring, Alternate Method

5.1.5 Remote Monitoring of Temperature

Using the SIM-BNC Interlock connector located on the back panel of the amplifier, you can remotely monitor the temperature at the heat-sinks of the amplifier.

Remote Monitoring of Temperature

Purpose: Use a voltage meter to monitor temperature at the heat-sinks.

Method: Connect a voltage meter to monitor the temperature at the heatsinks of the amplifier. Connect across PIN 9 (TEMP MONITOR) and PIN 10 (Sampled Common). See **Figure 5.7**.

Signal Type: DC

Level: (VDC * 100) - 273 = degrees Celsius

IMPORTANT: This circuit has a 1K build-out resistor. Make sure the monitor function has sufficient impedance to avoid accidentally influencing status. Most digital multimeters have an input impedance of 1 megohm and would work well for this application.

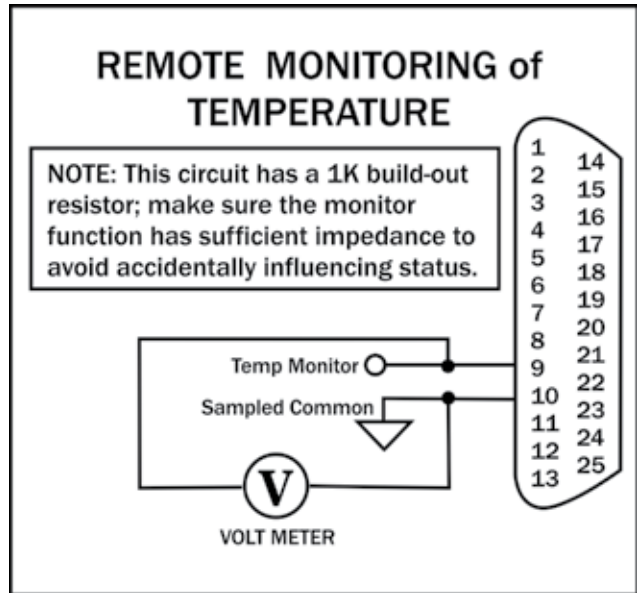

Figure 5.7– Remote Monitoring of Temperature

Blanking Circuit Activation

Purpose: Activate the blanking circuit that shuts down the amplifier output stage in less than 10 μs.

Method: Build a switchable circuit using an external, isolated 5V power supply that can apply a +5V signal to PIN 8. Connect across PIN 8 (Blanking) and PIN 18 (Blanking Return). See **Figure 5.8**.

Signal Type: DC

Level when Asserted: 5-6 Vdc

Level when Deasserted: 0 Vdc

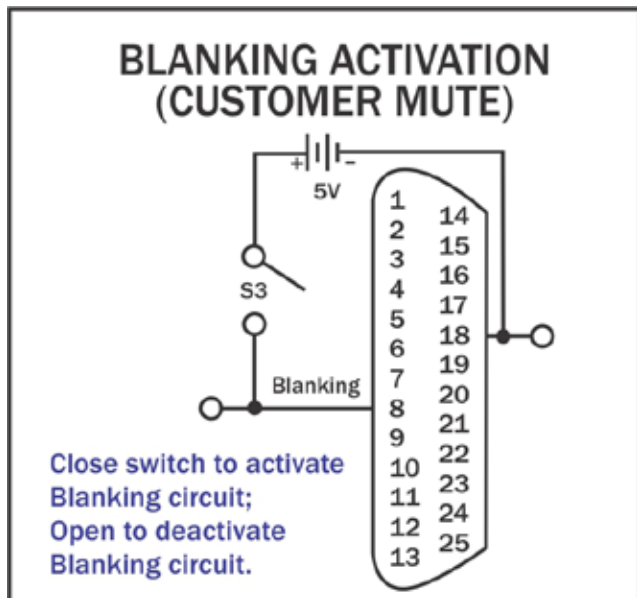

Figure 5.8 – Blanking Activation

5.2 Controlled Current Operation

The procedures outlined in this section assume competence on the part of the reader in terms of amplifier systems, electronic components, and good electronic safety and working practices.

NOTE: Before configuring your 7800 series system for controlled-current operation, please contact AE Techron Technical Support for the proper settings to use for your application.

5.2.1 Controlled-Voltage vs. Controlled-Current Modes of Operation

AE Techron 7800 series amplifiers can be field-configured to operate as **Voltage Amplifiers** (Voltage-Controlled Voltage Source) or as **Trans-conductance Amplifiers** (Voltage-Controlled Current Source). The mode selection is made via a jumper setting located on the amplifier main board. See the **Advanced Configuration** section for more information.

When configured as a **Controlled-Voltage** source (voltage amplifier), the amplifier will provide an output voltage that is constant and proportional to the control (input) voltage. If the load's impedance changes, the amplifier will seek to maintain this ratio of input to output voltage by increasing or decreasing the current it produces, as long as it is within the amplifier's ability to create the required current. Use this mode if you want the output voltage waveform to be like the input waveform (see **Figure 5.9**).

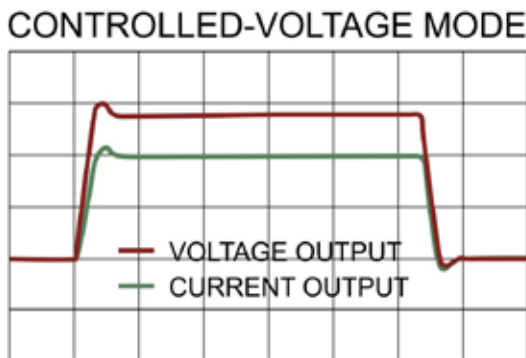

Figure 5.9 – Input to Output Comparison, Controlled-Voltage Operation

Conversely, when configured as a **Controlled-Current** source (transconductance amplifier), the amplifier will provide an output current that is constant and proportional to the control (input) voltage. If the load's impedance changes, the amplifier will seek to maintain this transconductance (ratio of input voltage to output current) by increasing or decreasing the voltage it produces, as long as it is within the amplifier's ability to create the required voltage. Use this mode if you want the output current waveform to be like the input waveform (see **Figure 5.10**).

5.2.2 Safety and Operation Considerations for Controlled Current Operation

When an AE Techron amplifier is configured as a Controlled Current source, care needs to be exercised in its operation. **Any voltage controlled current source should never be turned on without a load, (with some impedance, real or effective) connected to its output terminals.** When asked to operate in this way, any current source (including an AE Techron amplifier) will increase its output voltage in an attempt to drive the requested current into the load. In an open-circuit condition, creating current flow will be impossible. The current source will increase its output voltage until it reaches its voltage limit. This is a potentially dangerous condition for both the AE Techron amplifier and for any user who might come in contact with the amplifier output terminals.

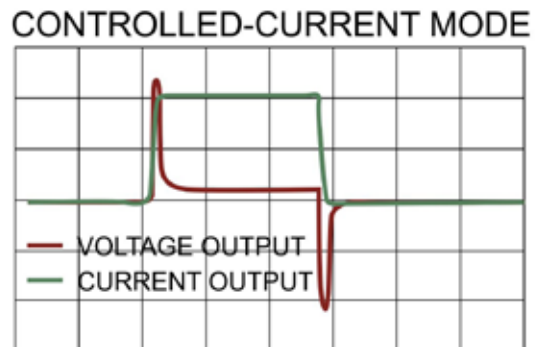

Figure 5.10 – Input to Output Comparison, Controlled-Current Operation

When operating in Controlled Current (CC) mode, a compensation circuit is required to ensure accurate output current. Since the load is a critical circuit component in CC mode, the inductive and resistive values of the load will determine the required compensation values. While the factory-default compensation setting will be sufficient for some applications, the compensation setting may also be adjusted in the field. The following section describes methods for determining and setting proper compensation when operating in Controlled-Current mode.

5.2.3 Controlling Compensation for CC Operation

AE Techron 7800 series amplifiers can be configured for either Controlled Voltage (CV) or Controlled Current (CC) mode of operation. When operating the amplifier in Controlled Voltage (CV) mode, compensation is not required. However, when operating in Controlled Current (CC) mode, the amplifier load becomes an integral part of the system. In order to ensure system stability and to control available bandwidth, compensation via an RC network is required for CC operation. The following steps will allow you to compensate your amplifier for operation in CC mode safely and effectively.

STEP 1: Check Amplifier Operation in CV mode.

We recommend that you power-up and enable the amplifier in Controlled Voltage mode without attaching a load before configuring your amplifier for Controlled Current operation. This will allow you to verify that the input signal and the amplifier are operating correctly.

Once this initial check is completed, power down the amplifier and access DIP switch #1 on the amplifier main board to place the amplifier in CC mode. (Refer to the **Advanced Configuration** section for more information.)

One of two compensation settings can be selected via DIP switch #2 on the main board: CC1 which

enables the factory-installed RC network (see **Figure 5.11**), or CC2 which allows installation of a custom RC network.

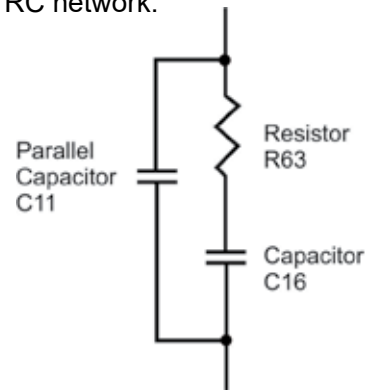

Figure 5.11 – Factory-installed Default RC Network

STEP 2: Determine Required Compensation.

When operating an amplifier in Controlled Current mode, the load becomes an integral part of the system. In order to determine the required compensation for your load, begin by consulting the following table to determine the approximate

compensation capacitance (C) required based on the inductance of your load: Note that these calculations are based on empirical measurements and are approximate.

	Load Inductance (L)		
	<200 μ H	<>200 μ H – <1 mH	>1 mH
Compensation Capacitance (CC)	0.001 μ F	0.01 μ F	0.1 μ F

NOTE: Load Resistance (R) is assumed to be <5 ohms.

STEP 3: Determine if Default or Custom Compensation is Required.

If your load inductance is between 200 microHenries and 1 milliHenry, and your load resistance is less than 5 ohms, then you can likely use the default compensation provided by the amplifier’s factory-installed RC network. To select the factory-default compensation, please see **STEP 4** below.

If your load inductance falls outside of the mid-range, or if your load resistance is greater than 5 ohms, then you must calculate your required compensation. If, after calculating your required compensation, you determine that the default compensation will be insufficient for your load, then you will need to enable and install a custom RC network. See **STEP 6** below.

STEP 4: (Optional) Verify Suitability of Default Compensation (CC1)

If desired, the following values of the components contained in the default RC network can be used with the formulas provided in **STEP 5** below to verify the suitability of the default compensation for your uses.

Compensation Resistor: 68.1k ohms

Compensation Capacitor: 47 nF

Parallel Capacitor: 100 pF

STEP 5: Calculating Values for an RC Network for Custom Compensation

If the default RC network does not provide suitable compensation for your intended load, you will need to install a custom RC network that is matched to your load. This network will require two components (a resistor (R) and a capacitor (C)) to be installed on the main board. To calculate the approximate values required for each component, use the following formulas.

COMPENSATION FORMULAS:

To find the value for the resistor (Rc) in the RC network:

$Rc = 20,000 \times 3.14 \times L \times BW$ where:

Rc is compensation resistance in ohms.

L is load inductance in henries.

BW is bandwidth in hertz.

To find the value for the capacitor (Cc) in the RC network:

$Cc = L / (R \times Rc)$

where:

Cc is compensation capacitance in farads.

L is load inductance in henries.



R is resistance of load in ohms.

Rc is compensation resistance in ohms.

STEP 6: Installing and Enabling the Custom RC Network

Once an approximate Rc and Cc have been computed, these values will need to be evaluated. To do this, you will need to install the custom components on the amplifier’s main board and enable the alternate compensation network (CC2).

The main board can be accessed by removing the amplifier top cover. To remove the amplifier top cover, complete the steps detailed in the following section.

	<h2>WARNING</h2>
<p>Do not attempt to access the Main Board while the amplifier is running. Turn the amplifier off and disconnect the AC Mains before removing the amplifier front panel.</p>	
	<h2>CAUTION</h2>
<p>After turning the amplifier off, let the unit sit for 3-5 minutes before removing the front panel. This will allow the electrical charge in the Power Supply capacitors to discharge.</p>	

Accessing the Main Board

The amplifier Main Board can be accessed by removing the amplifier front panel.

IMPORTANT: Before removing the Front Panel, make sure the amplifier is turned off for at least 3-5 minutes and the AC mains are disconnected.

Tool Required

Torx T15 driver

Procedure

1. Turn the power to the amplifier “OFF”.
2. Remove the four hex-head screws, located along the left and right edges of the amplifier front panel using a Torx T15 driver.
3. Remove the front cover by pulling straight towards you.

Custom Compensation Network Installation

When the 7548/7794/7796/7796HC amplifier is used in Controlled-Current mode, the current control loop is tuned with an RC network. The factory default network (CC1) provides 68.1k ohm resistance and 47 nF capacitance. If this default network is not adequate for your application and load, CC2 can be used to install a custom RC network on the amplifier main board.

First, install components with the required values in the main board at locations **R5** and **C2** as shown in **Figure 5.12**.

To change the compensation network, locate **Compensation (CC1/CC2)** DIP switch (SW#2) on the main board. Move the switch to the **Down** position to enable the path to the custom network (CC2).



Figure 5.12 – Custom Compensation Component Locations

STEP 7: Optimizing the Compensation Values

Remember the load you are connecting is a part of the system and the amplifier should not be turned on without the load being connected.

After installing the components, check to ensure that the Operation DIP switch (SW#1) is set to Current mode, then power up the amplifier without signal input.

To begin testing, input a square wave with a frequency of 100 Hz to 1 kHz, or a squared pulse at a low level (typically 0.25 to 2.0 volts). A limited-rise-time, repetitive pulse of low duty cycle is preferred.

Observe the output current through a current monitor or current probe. Look for clean transition edges. The presence of ringing or rounding on the transition edges indicates compensation problems. (See **Figure 5.13.**)

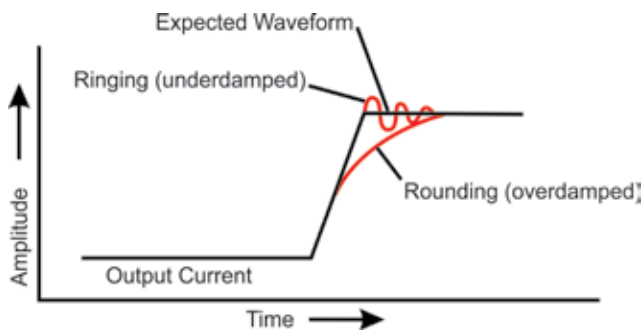

Figure 5.13 – Compensation Effects on Waveform

If a change in compensation is necessary, an adjustment to the resistor component of the Compensation circuit is probably required.

If the output current waveform is ringing, the circuit is underdamped: You have too much gain and should lower the resistance (see **Figure 5.14.**)

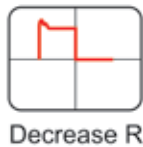

Figure 5.14 – Square Wave Showing a Decrease in R is Required

If the output current waveform is rounded, the circuit is overdamped: You have too little gain and should increase resistance (see **Figure 5.15.**)

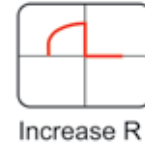

Figure 5.15 – Square Wave Showing an Increase in R is Required

If the output current waveform is neither underdamped or overdamped, but the top of the square-wave is not level, then you should instead increase the capacitor value (see **Figure 5.16.**)

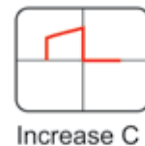

Figure 5.16 – Square Wave Showing an Increase in C is Required

When making adjustments:

Resistor: Increase or decrease resistance values in increments of +/- 10%.

Capacitor: Incrementally increase capacitor values by a factor of 2 or 3.

After final adjustments have been made to the circuit, the final waveform for your planned application should be tested to confirm the amplifier's compensation setting.

NOTE:

- If possible, use 1% metal film resistors. AE Techtron discourages installation of potentiometers in the resistor location of the compensation circuit because this can decrease stability and may increase inductance.
- The parallel capacitor in the RC network serves to increase stability but can be removed, if it is not required for system stability. If the parallel capacitor is used, it will usually decrease the value of resistance needed.
- In multiple amplifier systems, expect to decrease the value of R63 in series systems by 1/2.

6 Maintenance

Simple maintenance can be performed by the user to help keep the equipment operational. The following routine maintenance is designed to prevent problems before they occur. See the “Troubleshooting” section for recommendations for restoring the equipment to operation after an error condition has occurred.

Preventative maintenance is recommended after the first 250 hours of operation, and every three months or 250 hours thereafter. If the equipment environment is dirty or dusty, preventative maintenance should be performed more frequently.

The procedures outlined in this section are directed towards an experienced electronics technician; it assumes that the technician has knowledge of typical electronics safety and maintenance procedures.

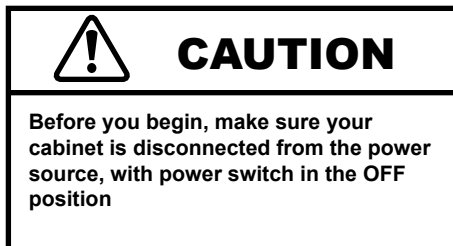

6.1 Clean Amplifier Filter and Grills

6.1.1 Tools Required

The recommended equipment and supplies needed to perform the functions required for this task are described below.

- Torx T15 driver
- Vacuum cleaner
- Damp cloth (use water only or a mild soap diluted in water)

To ensure adequate cooling and maximum efficiency of the internal cooling fans, the amplifier module's front and rear grills should be cleaned periodically. To clean the amplifier grills and filter, complete the following steps:

1. Turn the system OFF. Disconnect the amplifier from its power source.
2. Remove the four Torx-head screws, located along the left and right edges of the front panel of each amplifier module using a Torx T15 driver. Retain.
3. Remove the amplifier modules' front covers by pulling straight towards you.
4. Using a vacuum cleaner, vacuum the front and rear ventilation grills. Vacuum the filters behind the front ventilation grill.
5. Using a damp cloth, clean the front and rear ventilation grills. Dry with a clean cloth or allow to air dry. **IMPORTANT: Grills should be completely dry before plugging in or restarting the system.**
6. Reinstall amplifier modules' front filters and ventilation grills. Secure the front grills using the retained screws

6.2 Clean Cabinet Interior

6.2.1 Tools Required

The recommended equipment and supplies needed to perform the functions required for this task are described below.

- Vacuum cleaner
1. Using a vacuum cleaner, remove any dust that has accumulated within the cabinet interior.
 2. Close the cabinet rear door and restart the system. Check for any problems such as inoperative fans that might cause overheating.

7 Troubleshooting

If the 7800 series system is not operating correctly, review the topics below for help with troubleshooting the problem. If the condition or error you are experiencing is not listed below, please contact **AE Technon Technical Support** at 574-295-9495 for additional help.

PROBLEM: The system has no signal output.

A: Check to make sure signal input is being generated by the signal generator and that the input cable is securely attached to the amplifier input.

PROBLEM: System does not power on; no LEDs are lit on any of the amplifier modules.

A: Check that the AC mains are connected to the system and the AC mains is switched on.

PROBLEM: On one or more of the amplifier modules, no LEDs are lit and/or fans are inoperative.

A: Check the breaker/power switches on all amplifier modules to make sure they are in the on position. See **Figure 5.1**.



Figure 5.1 – Amplifier Module’s Breaker/Power Switch Location



Figure 5.2 – Amplifier Module’s Low-voltage Fuse Location

Check the fuse F1 on each amplifier module. Locate the fuse cover on the amplifier back panel and turn the cover counter-clockwise to remove. Remove the fuse, inspect, and replace if needed with 1A slow blow fuse. See **Figure 5.2**

PROBLEM: One or more of the amplifier modules is displaying the Overvoltage Warning message/ LED.

A: The amplifier modules will protect themselves from AC mains voltage that is 10% above the 230V rated operating voltage. If this condition occurs, reduce the AC mains voltage to the proper level. When the line voltage condition is corrected, the amplifier modules will automatically reset, and the system will return to Run mode.

If one or more amplifier modules do not automatically reset, the amplifier’s three internal transformers may need to be rewired. See the Factory Service information at the end of this section.

PROBLEM: One or more of the amplifier modules is displaying the Overtemp Warning message/LED.

A: One or more amplifier modules may overheat due to one or both of the following conditions: Excessive power requirements and/or inadequate air flow.

An amplifier module will overheat if the required power exceeds the system’s capabilities. High duty cycles and low-impedance loads are especially prone to cause overheating. To see if excess power requirements are causing overheating, check the following:

1. Check the “Specifications” section in this manual to verify that your application’s requirements fall within the capabilities of this system.
2. Check for faulty output connectors and/or load.
3. Check for undesired DC offset at the output and on the input signal.

If one or more amplifier modules chronically overheats with suitable power and load conditions,

then the cabinet or amplifier may not be receiving adequate airflow. Check the following to determine the cause of inadequate airflow:

1. Check air filters for excess dirt and dust. Perform the steps outlined in the “Maintenance” section to clean the amplifier filters and cabinet.
2. Visually inspect fans to assure correct operation while the system is on. Any inoperative, visibly slow, or reverse-spinning fans should be replaced. Please see the Factory Service information at the end of this section.

An OverTemp condition places the unit in Standby mode. If the OverTemp pulse is extremely short, as in the case of defective wiring or switches, the OverTemp pulse may be too brief to observe.

Resetting After Overtemp: To reset the system after an OverTemp has occurred, make sure fans are running in all the amplifier modules, then remove the input signal from the system input. Allow the fans to run for five minutes, and then push the Reset button on the amplifier module(s) reporting the Overtemp Warning to reset the system.

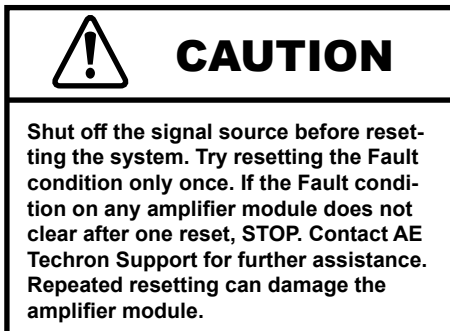

PROBLEM: One or more of the amplifier modules is displaying the Output Device Fault Warning message/LED.

A: The amplifier modules contain protection circuitry that disables the module if an output stage is behaving abnormally. This usually indicates an output transistor has shorted.

To clear the Fault condition, follow these steps:

1. Turn off the signal source.
2. Turn off the system AC mains.
3. Turn AC mains power back on. If the Fault LED doesn't illuminate again, turn the signal source on.
4. If the Fault LED is still illuminated and the Fault condition doesn't clear, return the amplifier module for Factory Service. Please see the Factory Service information at the end of this section.

7.1 Factory Service:

If the troubleshooting procedures are unsuccessful, the 7800 series system may need to be returned for Factory Service. All units under warranty will be serviced free of charge (customer is responsible for one-way shipping charges as well as any custom fees, duties, and/or taxes). Please review the “Warranty.” for more information.

All service units must be given Return Authorization Tickets by AE Techron, Inc. before being returned. Return Authorization Tickets can be requested on our website or by contacting our Customer Service Department.

Please take extra care when packaging your unit for repair. It should be returned in its original packaging or a suitable alternative. Replacement packaging materials can be purchased for a nominal fee.

Please send all service units to the following address and be sure to include your Return Authorization Ticket Number on the box.

AE Techron, Inc.

Attn: Service Department / RMA#

2507 Warren Street

Elkhart, IN 46516