

TECHRON[®]

TECHNICAL MANUAL
Operating Documentation

8607
GRADIENT
AMPLIFIER

Techron Division of Crown International, Inc., 1718 W. Mishawaka Road, Elkhart, IN 46517-4095

REVISION HISTORY

REV	DATE	REASON FOR CHANGE
A	Dec 1988	Preliminary Version
0	April 1989	Initial Release
1	May 1990	General Update
2	Feb. 1992	General Update
3	Aug 1994	DAC Replacement Update

LIST OF EFFECTIVE PAGES

PAGE	REV
Title Page	2
A	3
i to v	1
v	3
1-1 to 1-2	1
2-1 to 2-6	1
2-7	3
2-8 to 2-16	1
3-1	1
3-2	1
3-3 to 3-8	1
4-1 to 4-18	1
5-1 to 5-16	1
6-1 to 6-4	1
7-1 to 7-7	1
7-8	2
7-9 to 7-13	1
7-14 to 7-15	2
7-16 to 7-17	1
7-18	2
7-19 to 7-33	1
7-34	3
7-35 to 7-39	1
7-40	3
7-41 to 7-44	1
7-45	3
7-46 to 7-59	1
A-1 to A-2	2
B-1 to B-2	1

TABLE OF CONTENTS

SECTION 1. SAFETY	1-1
1.1. INTRODUCTION	1-1
1.2. DISCONNECTING POWER SUPPLY	1-1
1.3. Discharging Capacitors	1-2
1.4. Floating Ground	1-2
1.5. Handling Main Circuit Board	1-2
SECTION 2. THEORY OF OPERATION	2-1
2.1. CONCEPTS	2-1
2.1.1. Output Stage Topology	2-1
2.1.2. Output Stage	2-1
2.1.3. Output Stage Terminology	2-2
2.1.4. Transistor Topologies	2-2
2.1.5. Bridge Stages	2-3
2.1.6. Protection Circuitry	2-3
2.2. OUTPUT STAGES	2-3
2.2.1. NPN Stage	2-4
2.2.2. Output Drivers	2-4
2.2.3. Predriver	2-4
2.2.4. Output Stage Bias	2-4
2.2.5. Fault Detection	2-4
2.2.6. PNP Stages	2-5
2.2.7. Protection Temperature Sensors	2-5
2.2.8. Output Terminator	2-5
2.2.9. Flyback Diode	2-5
2.2.10. Current Sampling	2-5
2.3. GAIN STAGES	2-5
2.3.1. Last Voltage Amplifier	2-5
2.3.2. Error Amplifier	2-6
2.3.3. Bridge Balance Amp	2-6
2.4. INPUT (SIGNAL PROCESSING & CURRENT CONTROL)	2-7
2.4.1. Power Up Reset	2-7
2.4.2. Analog Input	2-7
2.4.3. Shim Input	2-7
2.4.4. Controlled Current Mode	2-8
2.4.4.1. Current Control Amplifier	2-8
2.4.4.2. Current Sense Amplifier	2-8
2.4.5. Input Clipper	2-8
2.4.6. Current Monitor Output	2-8
2.4.7. Current Loop Compensation	2-8
2.4.8. Eddy Current Correction	2-8
2.4.9. Amplifier Enable	2-9
2.5. PROTECTION CIRCUITRY	2-9
2.5.1. Output Transistor Temperature	2-9
2.5.2. Simulator Output	2-10

2.5.	PROTECTION CIRCUITRY (Continued)	
2.5.3.	Amplifier Disable	2-10
2.5.4.	Output Stage Fault	2-10
2.5.5.	Thermal Protection Shutdown	2-10
2.6.	STATUS AND INTERLOCK	2-11
2.6.1.	Interlock	2-11
2.6.2.	Startup delay	2-11
2.6.3.	Hi Line Voltage	2-11
2.6.4.	Fault	2-11
2.6.5.	Overtemp	2-12
2.6.6.	Overload	2-12
2.7.	POWER SUPPLIES	2-12
2.7.1.	Control Power Supply	2-13
2.7.2.	Vcc Power Supply	2-13
2.7.3.	V1 and V2	2-14
2.7.4.	BiLevel Local Power Supply	2-14
2.7.5.	Switch Control	2-14
2.7.6.	Protection	2-15
2.8.	SYSTEM THEORY	2-16
SECTION 3.	TROUBLESHOOTING	3-1
3.1.	INTRODUCTION TO TROUBLESHOOTING MODEL 8607	3-1
3.2.	REPAIR PRECAUTIONS	3-1
3.3.	PREPARATION FOR TROUBLESHOOTING	3-1
3.3.1.	Equipment Requirements	3-1
3.3.2.	Switch Settings	3-3
3.3.3.	Signal Source	3-3
3.3.3.1.	Analog Input	3-3
3.3.3.2.	Digital Input	3-3
3.4.	MAKE THOROUGH VISUAL INSPECTION	3-3
3.5.	PREPARATION FOR TESTING UNDER POWER	3-3
3.6.	CHECK BY FUNCTION LIGHTS	3-4
3.7.	OUTPUT STAGE TEST	3-4
3.8.	TEST DRIVER AND PREDRIVER TRANSISTORS	3-5
3.9.	ISOLATE MAIN BOARD PROBLEM	3-5
3.10.	CHECK OUTPUT WAVEFORM OSCILLATIONS	3-6
3.11.	CHECK FOR DEFECTIVE THERMAL SWITCH OR THERMAL SWITCH WIRING	3-6
3.12.	CHECK FOR INADEQUATE COOLING AIR FLOW	3-6
3.13.	CHECK FOR OVERHEATING OF INDIVIDUAL OUTPUT WELL	3-6
3.14.	INTERLOCK AND STANDBY	3-7
3.15.	BILEVEL POWER SUPPLY TESTING	3-7
3.15.1.	In Circuit Test for Shorted FET Switch	3-7
3.15.2.	Individual FET Switch Test	3-8
3.15.3.	Test for Defective U405	3-8
3.15.4.	Test for Defective Q403	3-8
3.16.	COMPONENT REPLACEMENT	3-8
3.17.	RESTORATION FOLLOWING TROUBLESHOOTING	3-8
SECTION 4.	DISASSEMBLY AND ASSEMBLY	4-1
4.1.	INTRODUCTION TO DISASSEMBLY AND ASSEMBLY	4-1
4.2.	IMPORTANT SAFETY INFORMATION	4-1
4.2.1.	Introduction	4-1
4.2.2.	Disconnecting Power Supply and Discharging Capacitors	4-2
4.2.3.	Floating Ground	4-2

SECTION 4. DISASSEMBLY AND ASSEMBLY (CONTINUED)

4.3.	REMOVING AND INSTALLING A CABINET	4-2
4.4.	FRONT PANEL REMOVAL	4-3
4.5.	REMOVAL OF REAR, TOP, BOTTOM AND SIDE PANELS	4-3
4.6.	SERVICE OF OUTPUT SHELF COMPONENTS	4-4
4.6.1.	Flyback Diode Block, D607	4-6
4.6.2.	Current Sampling Resistor Assembly	4-7
4.6.3.	Servicing Bus Bar Assembly	4-7
4.6.4.	Foam Insulation	4-7
4.6.5.	FET Switch Service	4-7
4.6.6.	Control Board Service	4-8
4.6.7.	Switch Diode Replacement	4-8
4.6.8.	Termination Board Service	4-9
4.7.	SERVICING FANS	4-9
4.8.	POWER SUPPLY RECTIFIER BLOCK	4-10
4.9.	SOLID STATE RELAYS	4-10
4.10.	RIBBON CABLES SERVING J100, J200 AND J300	4-10
4.11.	SERVICING MAIN CURCUIT BOARD	4-11
4.12.	SERVICING POWER SUPPLY COMPONENTS	4-12
4.12.1.	Removal of Capacitors and Control Transformers	4-12
4.12.2.	Servicing of Capacitors	4-12
4.12.3.	Servicing of Low Voltage Control Transformer	4-13
4.12.4.	Servicing of Power Transformer	4-12
4.13.	SERVICING OUTPUT WELL COMPONENTS	4-14
4.13.1.	Removing and installing Output Wells	4-14
4.13.2.	Output Transistors	4-15
4.13.3.	Driver Transistors	4-16
4.13.4.	Emitter Resistors	4-16
4.13.5.	Electronic Heat Sensors, Wells 3 and 4 only	4-17
4.13.6.	Thermal Switch, Wells 1 and 2 only	4-18
4.13.7.	Bias Servo Transistor, Wells 1 and 4 only	4-18

SECTION 5. TESTING AND ADJUSTMENT

5.1.	INTRODUCTION TO TESTING AND ADJUSTMENT	5-1
5.2.	EQUIPMENT REQUIREMENTS	5-1
5.3.	PREPARATION FOR TESTING	5-1
5.4.	ADJUSTMENTS WITH A TECHRON GAE	5-2
5.4.1.	Initial GAE settings	5-2
5.5.	DISABLE/ENABLE AMPLIFIER	5-2
5.6.	AMPLIFIER GROUND	5-2
5.7.	INITIAL CONTROL SETTINGS	5-2
5.8.	POWER SUPPLY PRETEST	5-3
5.9.	PREPARATION FOR POWER ON TEST	5-3
5.10.	AMPLIFIER POWER ON TEST	5-4
5.11.	ANALOG FUNCTION TEST	5-4
5.11.1.	Check +/- Vcc Voltage	5-4
5.11.2.	Oscillation Tests	5-5
5.11.3.	Check +1 and -1 Inputs	5-5
5.11.4.	Check Overload Reset	5-5
5.11.5.	Current Monitor Zero Adjustment	5-6
5.11.6.	CMR Adjustment	5-6
5.11.7.	Output Stage Bias Adjustment	5-7
5.11.8.	Amplifier Offset Adjustment	5-7

SECTION 5. TESTING AND ADJUSTMENT (CONTINUED)

5.11.9.	Static Bridge Balance	5-7
5.11.10.	Adjust and Verify Simulator Zero	5-8
5.11.11.	Adjust Analog Input Common Mode	5-9
5.11.12.	Adjust Dynamic Gain	5-9
5.11.13.	Set Analog Input Offset	5-9
5.12.	DIGITAL FUNCTION TESTS	5-9
5.12.1.	DAC Calibration	5-9
5.12.2.	Gate Adjustment	5-10
5.12.3.	Adjust Clipper	5-10
5.12.4.	Adjust Current Monitor Gain	5-10
5.12.5.	Check Linearity >12.5 Amps	5-10
5.12.6.	Check Current Monitor Output	5-10
5.12.7.	Check Linearity <12.5 Amps	5-11
5.12.8.	Check Balanced Differential Input	5-11
5.13.	AMPLIFIER PROTECTION TESTS	5-12
5.13.1.	Check Faulty Circuit	5-12
5.13.2.	Test Operation of Mechanical Thermal Switches	5-12
5.13.3.	Reliability	5-12
5.13.4.	Adjust High Mains Cutoff	5-12
5.14.	RESTORATION	5-12
5.14.1.	Power Down	5-12
5.14.2.	Power Up	5-13
5.14.3.	LED Status Digits	5-13
5.15.	COMPONENT INTERACTION LIST	5-13
SECTION 6.	EDDY CURRENT BOARD	6-1
6.1.	INTRODUCTION	6-1
6.2.	SETUP FOR TESTING	6-1
6.3.	INITIAL TESTING	6-2
6.4.	VERIFY VOLTAGE REFERENCE	6-2
6.5.	VERIFY TIME CONSTANTS	6-3
6.6.	RETURN TO SERVICE	6-4
SECTION 7.	REPLACEMENT PARTS AND SCHEMATICS	7-1
7.1.	GENERAL PARTS INFORMATION	7-1
7.2.	STANDARD AND SPECIAL PARTS	7-1
7.3.	ORDERING PARTS	7-1
7.4.	SHIPMENT	7-1
7.5.	TERMS	7-1
7.6.	MAIN CHASSIS PARTS LIST	7-2
	MAIN CHASSIS EXPLODED VIEW	7-5
7.7	BUS BAR AND HEATSINK PARTS LIST	7-6
	BUS BAR AND HEATSINK EXPLODED VIEW	7-7
7.8	POWER SUPPLY PARTS LIST	7-8
	POWER SUPPLY EXPLODED VIEW	7-9
7.9.	OUTPUT ASSEMBLY PARTS LIST	7-10
	OUTPUT ASSEMBLY EXPLODED VIEW	7-11
7.10.	SCHEMATIC PARTS LIST	7-12
7.11.	EDDY CURRENT BOARD PARTS LIST	7-36
A.	CONNECTORS	A-1
B.	MASTER SLAVE INTERLOCK CABLE	B-1

LIST OF ILLUSTRATIONS

SECTION 1. SAFETY

Illustration 1-1	Capacitor Test Points	1-2
------------------	-----------------------------	-----

SECTION 2. THEORY OF OPERATION

Illustration 2-1	Totem-Pole Topology	2-1
Illustration 2-2	Full Bridge Topology	2-1
Illustration 2-3	Composite Transistor Topologies	2-2
Illustration 2-4	Bi-Level Current Flow	2-13

SECTION 3. TROUBLESHOOTING

Illustration 3-1	Switch and Jumper Locations	3-2
Illustration 3-2	Function Lights	3-4
Illustration 3-3	Output Transistor Test Points	3-4
Illustration 3-4	Driver Transistor Test Points	3-5
Illustration 3-5	Predriver Leads	3-4
Illustration 3-6	B4 Location	3-7
Illustration 3-7	FET Pins	3-8

SECTION 4. DISASSEMBLY AND ASSEMBLY

Illustration 4-1	Capacitor Test Points	4-2
Illustration 4-2	Amplifier Output Wiring	4-3
Illustration 4-3	Output Shelf In-Line Connections	4-4
Illustration 4-4	Interconnect Board	4-5
Illustration 4-5	Output Shelf Support	4-5
Illustration 4-6	Output Shelf Positioning	4-5
Illustration 4-7	Capacitor Terminal Assembly	4-6
Illustration 4-8	Flyback Diode Block Detail	4-6
Illustration 4-9	Termination Board Solder Points	4-9
Illustration 4-10	Fan Connector Matching	4-9
Illustration 4-11	Power Supply Rectifier Block	4-10
Illustration 4-12	Main Circuit Board Connections	4-11
Illustration 4-13	Capacitor Terminal Assembly	4-11
Illustration 4-14	Output Well Orientation	4-14
Illustration 4-15	PNP Output Wells	4-15
Illustration 4-16	Driver Transistor Position	4-16
Illustration 4-17	Emitter Resistor Leads	4-16
Illustration 4-18	Electronic Heat Sensors	4-17
Illustration 4-19	Thermal Switch Location	4-18
Illustration 4-20	Bias Servo Transistor	4-18

SECTION 5. TESTING AND ADJUSTMENT

Illustration 5-1	Adjustment Points A	5-2
Illustration 5-2	Pre-Test Wave Form A	5-4
Illustration 5-3	Pre-Test Wave Form B	5-4
Illustration 5-4	Clip Point Wave Form	5-5
Illustration 5-5	Adjustment Points B	5-5
Illustration 5-6	Grounding Plug Schematic	5-6
Illustration 5-7	Bias Voltage Test Points	5-6
Illustration 5-8	Test Probe	5-7
Illustration 5-9	Adjustment Points C	5-7
Illustration 5-10	Common Mode Input Connection	5-9
Illustration 5-11	Adjustment Points D	5-9
Illustration 5-12	Clipper Adjust Waveform A	5-10
Illustration 5-13	Clipper Adjust Waveform B	5-10

SECTION 5. TESTING AND ADJUSTMENT

Illustration 5-14	Function #10-12 Waveforms	5-11
Illustration 5-15	Adjustment Points E	5-11
Illustration 5-16	Adjustment Points F	5-12
Illustration 5-17	Jumpers for Restoration	5-13

SECTION 6. EDDY CURRENT BOARD 6-1

Illustration 6-1	Test Setup with GAE	6-1
Illustration 6-2	Eddy Current Board Adjustments	6-2
Illustration 6-3	Test Setup without GAE	6-3

SECTION 7. EXPLODED VIEWS AND PARTS LIST 7-1

Illustration 7-1	Main Chassis Exploded View	7-5
Illustration 7-2	Bus Bar and Heat Sink Exploded View	7-7
Illustration 7-3	Power Supply Exploded View	7-9
Illustration 7-4	Output Assembly Exploded View	7-11
Illustration 7-5	Hi NPN Predriver Board	7-38
Illustration 7-6	Hi PNP Predriver Board	7-38
Illustration 7-7	Low NPN Predriver Board	7-38
Illustration 7-8	Low PNP Predriver Board	7-38
Illustration 7-9	Bi-Level Control	7-39
Illustration 7-10	Terminator Circuit Board	7-39
Illustration 7-11	Eddy Current Board	7-39
Illustration 7-12	8607 Main Circuit Board	7-41
Illustration 7-13	8607 Block Diagram	7-43
Illustration 7-60	DAC Module Emulator Board	7-40

LIST OF TABLES

Table 3-1	Recommended Equipment	3-1
Table 3-2	Jumper and Switch Functions	3-2
Table 3-3	Test Settings	3-3
Table 3-4	Bilevel Power Supply Testing	3-7
Table 4-1	Resistor Color Matching	4-17
Table 5-1	Recommended Equipment	5-1
Table 5-2	GAE Initial Settings	5-2
Table 5-3	Initial Jumper and Switch Settings	5-3
Table 5-4	Temperature to Voltage Conversion	5-8
Table 5-5	Final Jumper Settings	5-13
Table 5-6	LED Conditions	5-13
Table 6-1	Initial Equipment Settings	6-2

LIST OF SCHEMATICS

Schematic, DAC Module	7-40
Schematic, 8607 Main Circuit Board - Amp Input Section	7-45
Schematic, 8607 Gain Stages	7-47
Schematic, 8607 Protection Circuit	7-49
Schematic, 8607 Bi-Level Power Supply	7-51
Schematic, 8607 Bi-Level Power Supply Controller	7-53
Schematic, 8607 Status and Interlock	7-55
Schematic, 8607 Output Stage	7-57
Schematic, Eddy Current Board	7-59

SECTION 1: SAFETY

WARNING!

Interne Heizkörper stehen unter Spannung. Zur Vermeidung eines elektrischen Schlages, Spannung abschalten und mindestens 2 Minuten warten zur Entladung der Kondensatoren, bevor das Gerät geöffnet wird. Keine vom Benutzer zu wartenden Teile im Gerät. Service Arbeiten sind nur von qualifiziertem Personal durchzuführen. Vor Gebrauch oder Installation ist die Bedienungsanleitung zu beachten. Dieses Gerät ist nur mit einer nach I.E.C. 601 - 1 geprüften Spannungsquelle zu verwenden.

WARNING!

Internal heat wells are electrically hot! To prevent electrical shock, disconnect power and allow a minimum of 2 minutes discharge time for power supply capacitors before removing covers. No user serviceable parts inside. Refer servicing to qualified technician. Refer to user manual before installing or operating.

1.1. INTRODUCTION

Model 8607 operates with 208VAC 3 phase power.

WARNING!

Fatal electric shock hazard! The unit may carry lethal voltages whether or not main power source is connected. Do not attempt to service this unit in any manner unless you have read and understand this manual.

In addition to physical hazards to servicing personnel, certain electrical conditions could be damaging to components parts.

CAUTION

Accidental charges of static electricity could damage sensitive electronic components on the Main Circuit Board. Take appropriate precautions (e.g. wear wrist grounding strap) when handling this board.

1.2. DISCONNECTING POWER SUPPLY

Before attempting any servicing of Model 8607, shut down outside power supply by disconnecting plug from rear of unit.

Rear Circuit Breaker CB1 (Item 59 on Illustration 7-1) may be used to temporarily shut down power unit. However, disconnecting the plug provides an extra measure of safety to the service technician.

1.3. DISCHARGING CAPACITORS

Illustration 1-1 shows capacitors and power supply components as viewed from bottom of unit with bottom panel removed.

WARNING!

Fatal electric shock hazard! After the power source has been disconnected, the capacitors retain a lethal electric charge. Before performing any service work, verify capacitors are discharged.

Model 8607 includes a bleeder resistor that is designed to discharge capacitors within two minutes after power shut off. Do not perform any work inside the 8607 until two minutes have passed.

Before attempting any servicing of Model 8607, shut down the outside power supply by :

1. Turning off the power at CB1 (Rear Circuit Breaker, Item 59 on Illustration 7-1).
2. Disconnecting the AC main plug from the rear of the unit.

Note: The rear Circuit Breaker (CB1) may be used to temporarily shut down the power unit. However, disconnecting the plug provides an extra measure of safety to the service technician.

3. Wait two minutes for capacitors to discharge before touching any part of the amplifier.
4. Remove the bottom cover (Item 23 on Illustration 7-1) to expose the power supply capacitors.
5. Verify the capacitor discharge by connecting a voltmeter across the "+" and "-" terminals of the power supply capacitors (two places). Illustration 1-1 shows the test points.
6. The voltmeter should give a reading of less than 50 volts.

1.4. FLOATING GROUND

Internal electrical components of Model 8607 Amplifier are not grounded to chassis.

WARNING!

Grounding cannot be predicted by visual inspection. Until capacitors are allowed to discharge, high voltages must be assumed present at both capacitors, in capacitor wiring and at all points connected with capacitors.

Because of this floating ground feature, all test equipment used in servicing Model 8607 should *not* be connected to earth grounded. There is a possibility of spurious readings occurring from the use of grounded test equipment. Use an isolation amplifier to float test equipment from earth ground.

1.5. HANDLING MAIN CIRCUIT BOARD

CAUTION

Main circuit board can be damaged by accidental static electricity. Take appropriate precautions (e.g. wear wrist grounding strap) when handling this board.

When the main circuit board is in place and connected, the assembly is protected. However, this protection is not available when the four ribbon cables have been disconnected from the circuit board.

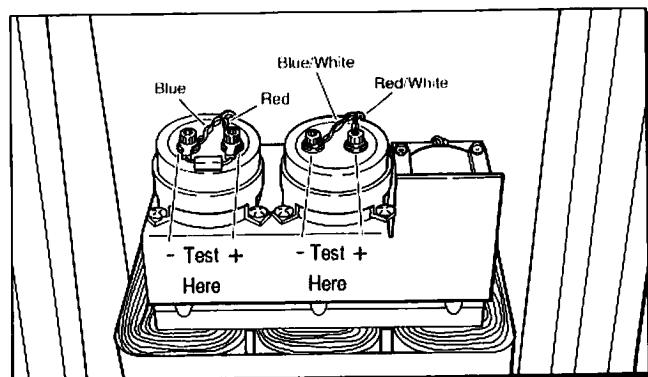

Illustration 1-1 Capacitor Test Points

SECTION 2. THEORY OF OPERATION

This section covers theory of operation in two parts. Sections 2.1 through 2.7 cover all aspects of the 8607 Gradient amplifier. Section 2.8 covers operation of two 8607 amplifiers driving a gradient coil.

2.1. CONCEPTS OF AMPLIFIER OPERATION

The fundamental objective of a power amplifier is to transfer energy from an available supply to a load in a prescribed/controlled manner. Voltages in excess of 160 peak volts and 180 amperes are available. The test signals require DC coupled response to the load with low noise at all frequencies. The load current may be the programmed output variable and not the voltage. This controlled current mode is useful in areas where the field produced by a coil needs to be proportional to coil current and not voltage.

2.1.1. Output Stage Topology

Illustrations 2-1 and 2-2 are block diagrams of the topologies commonly used for direct-coupled amplifiers. The totem-pole is the most common and makes available a peak voltage to the load of $1/2$ of the total supply voltage (V_{cc}) while exposing the output stage devices to stress from the total supply voltage ($2V_{cc}$). Only one half of the supply is used at a time, reducing the supply operating efficiency as well.

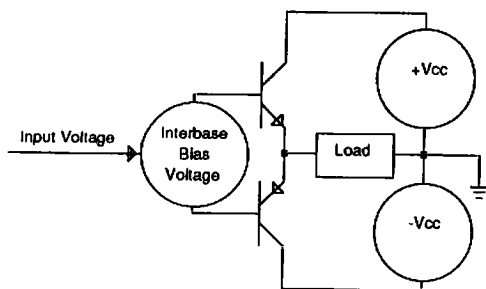

Illustration 2-1 Totem-Pole Topology

The 8607 amplifier uses full bridge output stage shown in Illustration 2-2 to make full use of the available supply voltage as the peak output to the load is $2V_{cc}$.

The peak-to-peak output voltage of the full bridge is actually twice the available supply voltage ($4V_{cc}$). The maximum voltage stress to the output stage devices is the same as in the totem-pole topology ($2V_{cc}$). The supply utilization is now total.

2.1.2. Output Stage

Operation of the full bridge to produce a positive output current requires that the output stages one and three be increased in conductance in synchrony and output stages two and four be decreased in synchrony, decreasing as one and three are increasing.

In class AB operation, the conductance of two and four would diminish to zero and stages one and three would increase to the level required to carry the desired positive peak output current. For a negative output current the roles of the pairs one and three and two and four are interchanged with two and four ultimately carrying the negative peak output current.

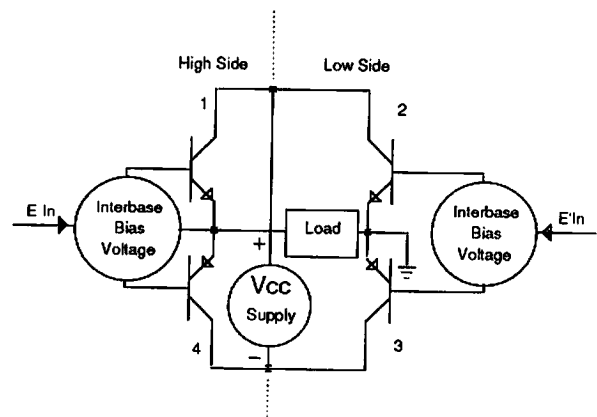

Illustration 2-2 Full Bridge Topology

2.1.3. Output Stage Terminology

The names one, two, three and four are not the names that are preferred for describing the output stages. Since the output stages are constructed with bipolar transistor devices, the preferred and more descriptive terminology is to name an output stage in terms of whether the stage acts as a giant NPN or PNP transistor and whether it is on the high (output) side of the load or low (ground) side of the load. Thus stage one is generally referred to as the high side NPN stage and stage three is referred to as the low side PNP stage.

2.1.4. Transistor Topologies

There are four basic composite transistor topologies (Illustration 2-3) which may be used in any configuration which can be derived by recursive application of the forms. Other three terminal devices such as FETs could be substituted for the bipolar transistors without loss of generality. In the application of the 8607 all of the devices of the output stages are bipolar.

The principal output devices are NPN transistors paralleled 20 times. They are driven in two groups of ten from a pair of NPN driver transistors (Darlington form). NPN stages use an NPN predriver (Darlington form) driving the drivers. PNP stages use a PNP predriver (Complementary form) driving the drivers.

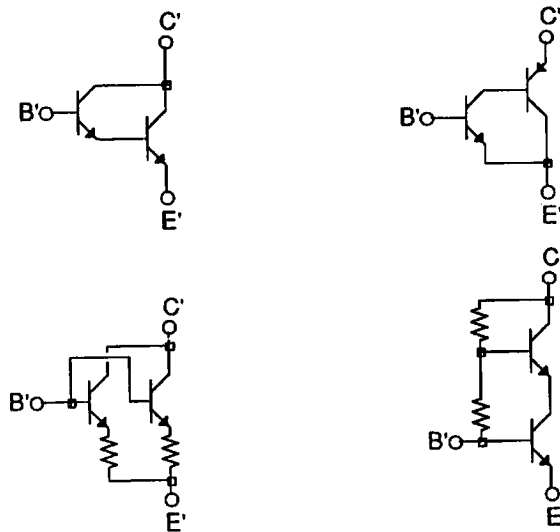

Illustration 2-3 Composite Transistor Topologies

2.1.5. Bridge Stages

The 8607 is built around a voltage amplifier made up of wide gain-bandwidth IC op amps which first drive the high side of the bridge. The low side of the bridge is in turn driven from the high side such that one half of the voltage of the output signal is imposed on the supply rails. This condition constitutes the proper synchrony of the stages of the bridge. Note that the amplifier dissipation is distributed evenly over 40 output devices for a single polarity of output current. Negative feedback is used liberally to acquire the control of the bridge balance and to insure the required overall linearity.

2.1.6. Protection Circuitry

Protection circuitry is used to prevent electrical damage to the amplifier's components due to excessive heat or current. If maintaining a high level of output current would cause the output semiconductors to overheat, the current must be reduced to limit the junction temperature. A fundamental problem of protecting output semiconductors is that they do not have an output terminal which indicates the junction temperature. The critical parameter is sealed inside opaque metal cases.

This has led to the use of simulation methods to predict the junction temperature. An electronic analog of the heating process is created which can be monitored for excessive equivalent temperature. An electronic multiplier is used to compute instantaneous power by computing the product of the semiconductor voltage and current. Its output is applied to an electrical impedance which is designed to have the same time characteristics as the junction. After the ambient temperature is added to the output, the result is an electrical analog proportional to the absolute temperature in degrees Kelvin of the output semiconductor junctions. This temperature information is then compared to the maximum allowed junction temperature of 200 degrees Centigrade and the current drive to the output devices is reduced to prevent the temperature from becoming excessive.

Electronic power supply interlocking is used to allow multiple amplifiers to power a common load. Should any one unit of a system not be able to operate, it is imperative that none of the units be active. The amplifiers must enter the ready state in unison. A disabled amplifier could be damaged by large output signals from its companion units.

The heatsink components are protected from excessive temperatures (over 150° Centigrade) by two thermal limit switches (see Illustration 4-19). Electronic current limiters prevent instantaneous current limits of the output devices from being exceeded.

The power transformer is protected against overtemperature conditions by internal limit switches which are coupled to the interlock and power control circuitry. Fault conditions in the power supply are protected with circuit breakers. A fault in the output stages is electronically detected and the main supplies are disabled until the control circuitry is reset by cycling the power to the amplifier.

2.2. OUTPUT STAGES

Each output stage or quadrant is built on a separate electrically isolated heatsink. Twenty NPN bipolar output transistors are directly mounted to each heatsink. By allowing each heat sink to be electrically isolated from the chassis and the other output stages, the transistors are able to be connected directly to the heatsink. This results in a lower junction temperature for the output transistors.

Each heatsink is a high-efficiency forced-air heat exchanger. The heatsink is constructed with aluminum fin-stock bonded to the outside of the two vertical risers of a thick "H"-shaped aluminum extrusion. The output semiconductors are mounted to the underside of the aluminum extrusion.

The twenty output transistors are driven by two NPN bipolar transistors, each driving ten of the outputs. Ten output transistors and respective driver transistors are mounted on the same side of the heatsink to provide thermal balance.

Wiring of the emitter and base circuits of the output and driver transistors is provided by two printed circuit boards which are placed at the bottom of the upper channel of the "H". The output transistor emitter wiring circuit board is below the output transistor base wiring circuit board. The circuit board material is a high-temperature material to allow operation to temperatures up to 150° Centigrade.

The entire output heatsink may be disconnected and removed from the amplifier by removing six fasteners and the output connector board which passes over the top of the heatsinks. Two of the fasteners at the middle of the heatsink are used to connect the high-current output to the bus bars. The remaining four fasteners at the ends of the heatsinks provide mechanical support.

2.2.1. HiNPN Stage (Well #1)

Refer to J0295-6, the schematic of the output stages. The high side NPN output well current is supplied by transistors Q600-609 and Q612-621. Emitter current is degenerated by resistors R601-610 and R615-624. Base current is removed from the output transistors by resistors R611 in parallel with R625 for Q612-Q621, and by R615 in parallel with R624 for Q600-Q609. The paralleled resistors are on opposite ends of the output well. A high-frequency load is provided for this stage by using a series RC formed by R600 and C600. The three other output stages use a similar component layout

2.2.2. Output Drivers

The output driver transistors are Q610 and Q611. Each drives half of the output transistors. Base emitter resistors R612 and R613 are used to set the quiescent current point of the driver transistors and to remove current from the base of each driver. This structure is common to all four of the output stages.

2.2.3. Predriver

Both drive transistors are driven by Q650 through a compensation network composed of L650, C650, and R650. These components are mounted on the predriver circuit board attached to the heatsink. Q650 base current can be removed by Q651 in the case of rapidly switching currents. A system would need to become unstable for Q651 to be used. The LoPNP well also employs a transistor for removing rapidly switching drive current.

2.2.4. Output Stage Bias

The quiescent bias current of the high side of the bridge is controlled by Q652 which is connected as a V_{BE} multiplier. Q652 is thermally joined to the heatsink and compensates for the base-emitter voltage temperature coefficient of the drivers and output transistors. The base-emitter coefficient of the predriver is compensated by D650. R651 in series with R652 is used to adjust the bias. With no load current and heatsinks at 25° Centigrade, the bias may be adjusted by setting the voltage across either R611 or R614 to 0.400VDC. R654 is used to reduce any sensitivity of the quiescent bias point to the current flowing through the bias circuitry from the last voltage amplifiers of the gain stages. C652 prevents instability in the bias servo. The NPN low side output stage has the same construction and biasing circuits.

C654 and R655 join to the input of the high side PNP output stage. The result is reduced inductance at the input of each stage. This improves stability in the predriver stages. C653 and C651 compensate the entire output stage and provide a capacitive load to the current limited last voltage amplifiers to form a slew rate limit circuit.

2.2.5. Fault Detection

D600 and D601 sample the output current and drive the fault detector of the high side of the bridge. If an output transistor fails with a collector-to-emitter short, the rest of the output transistors will be powered by the current from of the base emitter junction of the failed device. The increased current through D600 or D601 will latch the fault detect circuitry of the amplifier.

2.2.6. PNP Stages

The PNP output stages are similar to each other in structure. The high side PNP stage has an identical output configuration to the NPN stage. Collector current is sampled by resistors R701-710 and R724-733. The predrivers are the major difference between NPN and PNP stages. Q750 drives current to the output transistor drivers, Q710 and Q711.

The compensation network is composed of R750, L750, and C750. C701, C751 and C752 are also used for stage compensation. D750 is used to temperature compensate the base-emitter junction voltage coefficient of Q750.

Additional high frequency compensation is incorporated in the low side bridge output stages by using RL networks in the emitter leads of the drivers. The inductors are constructed with ferrite beads. Using the low side NPN stages as an example, R857 and R858 are in parallel with the beads.

2.2.7. Protection Temperature Sensors

IC temperature sensors U800 and U900 are used on the low side stages to provide information to the protection circuitry. The output of each of these sensors is a current proportional to the absolute temperature. The signals +TEMP and -TEMP are scaled as 10 millivolts per degree Kelvin. Since the bridge is balanced in actual operation, the temperature of the NPN high side of the bridge should be essentially the same as the low side PNP output stage.

Overtemperature in the output heatsinks is prevented by bi-metal switches (TS1 and TS2) mounted on the heatsinks of the high side stages's.

2.2.8. Output Terminator

The four output stages drive the load current through an output terminator network composed of L90, C90, R91, C91, R92 and C92. This network is used to provide isolation from the load. A consistent high frequency load for the amplifier is provided by R90-92.

R90 is a resistor with a positive temperature coefficient, so rapidly rising output current will cause R90 to increase in resistance. This forces more current through L90, protecting R90 from excessive current

2.2.9. Flyback Diode

Flyback pulses from inductive loads are prevented from reverse biasing the output stages by D607. This high current bridge rectifier is mounted beneath the output shelf, next to the buss bar assembly. The buss bar assembly provides a low inductance, high current path for current from the four output stages to the output terminals

2.2.10. Current Sampling

Output current may be sampled by attaching the load to the terminal labeled, Sampled Common. R758-763 are used to produce a voltage for the current control circuitry of the input stages. Using the output terminal labeled Common, bypasses the current sampling resistors.

2.3. GAIN STAGES

The output is controlled by first driving the high side of the bridge. The low side of the bridge is driven such that half of the output voltage is impressed on the Vcc supplies. The gain stages control the drive and balance of the bridge.

2.3.1. Last Voltage Amplifier

Drive to the high side of the bridge comes from the last voltage amplifier. Q207 and Q208 form this amplifier. The last voltage amplifier is current limited by Q206 and Q209. This provides a slew limit due to the capacitive load. Q207 and Q208 are emitter-degenerated by R225 and R228.

Current limiting of the output stages is provided by diodes (D200-211) which limit the output current of the last voltage amplifiers.

R244 and C223, along with R245 and C224, reduce the inductance of these signals by joining the output signals and supplies respectively.

C210 and C212 provide high frequency feedback from the output to the input of the last voltage amplifiers. Input currents to the amplifiers are applied to their bases and R224 and R227.

Currents to the input of the last voltage amplifiers are provided by the grounded base stages of Q203 and Q204. Voltage dividers R249 and R246, and R247 and R248 provide operating states for Q203 and Q204 which prevent the forward biasing of the base collector junctions even when the output flyback diodes are forward biased and the Vcc supplies swing slightly beyond ground.

Complementary differential amplifiers drive Q204 and Q203. Q205 and Q202 amplify the difference between the feedback signal from the output and the input signal from U202. The feedback signal is attenuated by R226, C211, R216, R213, R215, R223, and R218. The input signal is coupled through R242, R214, C205, R219, R217 and C220. The operating state of Q202 and Q205 is such that collector operating voltage is insured no matter what signal conditions prevail. Emitter degeneracy with partial pole removal is provided by R211-212 and R220-221 and C221 and C208.

Current sources which bias Q202 and Q205 make it possible to interrupt the drive to the amplifier. The protection circuitry controls these bias currents. Q205 is biased by U200, a monolithic current mirror. Q200 and Q201 form a mirror to bias Q202. Emitter degeneracy is provided by R209 and R210. Controlled currents are provided by signals +LH and -LH from the protection circuits. R222 causes the input characteristic of U200 to be identical to the input characteristic of the mirror of Q200 and Q201.

2.3.2. Error Amplifier

Amplifier U202 is a high performance FET input op-amp. Local degeneracy is provided by C202. The main feedback loop around the power amplifier forms a non-inverting gain of 20 using R208, R251, C204 and R207. The -1 input used with slave operation is provided by R203, R250 and C226. U202's offset voltage is compensated by R204 through R205.

The voltage offset may be adjusted by placing S1 in the slave mode with no inputs connected to the +1 and -1 inputs and adjusting R204 for zero volts DC at the amplifier main output.

R202 and C200 function as a filter for RF input suppression. R200, R201, R253 and C225 form a non-inverting input of +1 gain for use with the slave mode of operation. R253 and C225 are used to provide phase compensation for the input to output transfer function. Likewise R250 and C226 compensate the -1 input phase response. S1 is used to switch between the master and slave modes of operation. In the master mode, the signal input to the power amplifier is derived from line X4 via S1-A. The -1 input is then grounded by S1-B.

2.3.3. Bridge Balance Amp

The bridge is balanced by U203 which drives the two low side output stages of the bridge through R243 and C222. This network provides some phase lead to improve the stability margin of the bridge balance loop. Current to drive the NPN low side output stage is provided by a current mirror composed of Q210, Q211, R229 and R230. This current source may be disabled by the protection circuitry by removing current from line +LL. In a similar manner, the current drive to the PNP low side output stage is provided by U201, a monolithic current mirror. U201 is driven from the protection circuit control line -LL. R231 is used to degenerate the input characteristics to mimic the NPN side mirror.

U203 drives the low side output stages such that the feedback signal through R232, C214 and R233 produces the same current that is produced by the input signal through R240 from the high side output. A DC current is flowing in R232 and R233 which is incidental to the process of monitoring the Vcc supplies. Offset errors caused by mismatch of R232 and R233 are compensated with the static balance control, R234 and R235. Signal balancing of the bridge is accomplished by using the dynamic balance control of R236 and R237 which shunt the feedback divider resistors, R238 and R239.

The static balance is adjusted by setting +Vcc equal in magnitude to -Vcc. Adjustment of the dynamic balance is accomplished by loading the amplifier for full current when driven by clip level low frequency signals. U203 should saturate just before U202.

Local degeneracy of U203 is provided by R241. R252 is used to reduce the interaction of the dynamic balance control and the amount of output current being drawn from the amplifier. The voltage on the output of U203 is determined by the degeneracy of the output stage and the current sampling resistors in the output assembly, R761-763.

Capacitors C201, C216, C217 and C218 bypass the 15 volt supplies to the op-amps. High frequency amplifiers such as U202 and U203 require local bypassing for stability.

2.4. INPUT (SIGNAL PROCESSING & CURRENT CONTROL)

The principle input to the gradient amplifier is through the digital inputs. These inputs are all optically isolated and designed to terminate a balanced line of EIA 422 type. Sixteen bits of parallel input are strobed by a strobe line. The input is of 2's complement form and is applied to a digital-to-analog converter (DAC) with two external 8 bit latches.

Data to the DAC, designated as socket U120, is inverted by the opto receivers U100-115. The MSB is further inverted for 2's complement representation. The inversion of the data allows the latch status indicators to be logic true, i.e. when a one is on the data line, the indicator will be lit. E102-E119 (Red) are used to indicate the data line status. E101 and E100 (Green) indicate DAC input status.

Output from the DAC is on pin 6 of socket U120. The output is also inverted which is corrected by a current to voltage conversion in U122. With a positive digital word the output of U122 is negative.

U121 is a precision, 10-volt reference with its output on pin 6. The amplifier current per LSB is controlled by adjusting P100. The DAC offset is adjustable using P101.

The data strobe also triggers monostable U124 which, in turn, gates the DAC output at U127. R101 is selected to produce a switch opening at U127 from 1 to 64 μ S long when the input is low. U127-A gates the input to U128-A. C128 and C129 hold the input to U128-A at the last DAC output level during DAC transitions. U127-B is balanced for charge transfer by C102 to produce a minimum disturbance to the signal.

Illustrations 7-60 and 7-61 on page 7-40 depict the DAC emulator module.

2.4.1. Power Up Reset

U132-A, R104, D106 and C142 form a power up reset stage. When the + input to U132-A goes negative to ground, the output of U132-A will go to -15 volts pulling the cathode of D103 to a TTL low. D104 prevents the RESET bar signal from going negative.

The remainder of U132, sections B and C, will force the DAC to a power up condition when the output of the protection circuitry is in current limit. All three sections of U132 are wired "or" so that any section will force the DAC to -1 LSB.

2.4.2. Analog Input

B7 selects the source of the input to the current control amplifier. The source can be the digital input (DAC output) or the analog input. The analog input is a differential input using U126 which receives its input signal from the front panel or rear panel J2 jacks. J101 male pin is the non-inverting input. J2-20 on the rear panel is the non-inverting input (left) and J2-19 is the inverting input.

2.4.3. Shim Input

S2 selects the front or rear analog input. The rear analog input is active when S2 is in the left most position. The analog input may be used as a shim input by leaving S2 in the rear input position and jumpering B9.

The common mode rejection of the analog input is tuned for optimum rejection at low frequencies by adjusting the trimmer of resistance network N100. The high frequency common mode is adjusted by tuning C123 which is tuned to set C122 and C123 equal to C140.

2.4.4. Controlled Current Mode

2.4.4.1. Current Control Amplifier

U128-B compares the current output of the amplifier with the desired current at the output of U128-A for controlled current mode operation. The current control amplifier, U128-B, is offset zeroed by P102 via R105. R106 and C130 provide the proper impedance to U128-B for minimum offset drift.

2.4.4.2. Current Sense Amplifier

The current of the amplifier is sensed by R758-763 and amplified by U130 for use in the current control loop. U130 acts as a differential amplifier with an adjustable gain control in the resistor network N102. Resistors R118 and R119 along with C137 and C138 compensate the sense resistors for their series inductance. The output of U130 is calibrated for 20 amperes per volt of output. The zero offset of U130 is eliminated by adjustment of P107 via R117.

2.4.5. Input Clipper

D100, D101, D102, Q100 and Q101 form a bridge with Q100 and Q101 performing as high quality diodes. This bridge clamps the output of U128-B if the output of U128-B exceeds 10.3 volts. The output level of the controlled current stage is adjusted by the values of R113, R114 and the setting of P106. This allows the amplifier to be operated with controlled output voltage limits that are not subject to minor line voltage fluctuations. By installing a jumper at B8, the voltage clipper is disabled.

2.4.6. Current Monitor Output

The current monitor output is made available on the front panel at J102 with R120 and a BNC connector. A differential output is made available to the rear panel J2 connector through J200 by using a unity gain inverter, U131. The gain of unity is set by R123 and R124. The output is isolated from capacitive loads by R121 and R122. R125 and C139 provide the proper source impedance for minimum offset errors of U131. The output is calibrated for 20 amps / volt.

2.4.7. Current Loop Compensation

B6 selects either network R116 and C136 or R115 and C135 as the principle compensation networks. The networks serve to control the open loop gain of the closed loop controlled current system.

In the controlled voltage mode of operation these compensation parts are not used.

2.4.8. Eddy Current Correction

Refer to Schematic J0356-6 for the discussion of the Eddy Current Correction circuit.

The 8607 eddy current board has four active RC circuits to provide pre-emphasis to the analog input of the amplifier. The correction circuit is inserted between the DAC input and the current control amplifier U128-B.

R3, R4 and U1-B form a buffer/divider to isolate and drive the four RC networks on the eddy current correction board. The R3,R4 divider is used to prevent overdriving of the common-mode input range of U3 and U4. The differentiating effects of the RC networks can double the peak voltages on step waveforms.

All four RC networks are similar and differ only by the capacitor used in the RC network. Only one of the networks will be discussed. C4, R8, and R17 comprise the RC network. U3-A is a high impedance buffer that eliminates interaction between the RC network and the gain adjustment pot, R21.

J6 is a service jumper. By placing the J6 jumper on pins A-B, the input of U3-A is connected to U2, a precision 10 volt DC source. The gain of the op-amp can then be adjusted by measuring the ratio of T1 and T2. The operating position for J6 is on pins B-C.

2.4.9. Amplifier Enable

The opto receiver for enabling amplifier, U117, may be bypassed for servicing. The amplifier will be enabled by installing jumper B4 in the manual position. An enable bar signal would otherwise be required of the interface to operate the amplifier. R100 acts to disable the unit if no jumper is present at B4. The amplifier is disabled by causing the protection circuit to gate off the current sources used to drive the output stages from the gain stages.

2.5. PROTECTION CIRCUITRY

The protection circuitry furnishes the amplifier with protection against:

1. Overheating of the output semiconductors.
2. Subsequent destruction as a result of output transistor failure.

Output peak current limiting was discussed in the section on the gain stages. The heatsinks are protected against materials damage due to over temperature by switches discussed in the section on the output stages. The main power transformer is protected against excessive coil heat by switches discussed in the section on power supplies.

2.5.1. Output Transistor Temperature

The output transistors are protected by simulation methods. An analog of a worst-case junction temperature is computed by taking the product of the output transistor current and voltage and applying this stimulus to a thermal impedance analog of a worst-case output device.

The actual heatsink temperature is added to result in an absolute temperature model of the junction temperature.

The low side of the bridge is used to compute the output transistor temperatures. This is based on simplicity and convenience since the low side of the bridge is common to ground. The high side of the bridge is constrained by the bridge balance amplifier to have the same dissipation as the low side. The low side PNP output stage conducts simultaneously with the high side NPN stage to produce a positive output current.

Q301 functions as a two quadrant multiplier to compute the product of current and voltage in the low side PNP output stage. Voltage is converted to a current by R322 which is connected to -Vcc. The current is sensed between the lines of -ICL and -ICOM. R321, N301(7-8), R323 and R332 provide a differential input to Q301. The differential output of Q301 is converted to single-ended by an op-amp current mirror built with U300-C, N301(1-2) and N301(2-3). The output current at N301(3), a virtual ground, is combined with currents from the heatsink temperature sensor U900 and a fixed temperature offset current through N301(3-5).

The network composed of N302(8,9,10), C306, and C307 is used to simulate the thermal impedance of a worst case transistor. At 25° Centigrade, the output of U300-D (T301) should be +12 Vdc. At 200° Centigrade the T301 will be -9 Vdc. With a 25° heatsink and no excitation, the offset balance of Q301, R334 is adjusted for +12 Vdc at T301. The voltage at T303 (-TEMP) should be +2.98 Vdc +/- 0.06 volts. The conversion factor of temperature to voltage is 10 millivolts per degree Centigrade. T302 of the low side NPN sensing protection circuitry should read the same voltage at 25° C.

The output at T301 is input to two amplifiers which are saturated in normal operation. U301-C and U301-D are saturated at their positive output limits in normal operation. A current from R325 and R326, through R324, defines the temperature threshold at which U301-D will begin a controlled gain (R329 and R330) transition from the saturated state. As the output of U301-D goes negative, the available drive current to Q205 which drives the high side NPN output stage is being removed and eventually zeroed.

If T301 becomes about -9.5 Vdc, then U301-C will follow suit becoming negative and removing the drive current to U201 which drives the low side PNP output stage. This threshold is defined by a current from R325 through R326 and R324. Since this must always coincide with a higher temperature than the temperature which disabled the high side of the bridge, it is never possible for the bridge to become unbalanced due to operation of the protection circuit.

If the low side of the bridge were protected before the high side of the bridge, the resulting bridge imbalance would cause unequal power dissipation in the high and low sides of the bridge. The gain of U301-C is controlled by R329 and R328. The operating current of the mirrors, U200 and U201 is determined by R331 and R327.

2.5.2. Simulator Output

The outputs of the simulation signals at T300 and T301 are available for external analysis. A balanced output from each simulator is produced for external observation. U302-C and U302-D provide the simulation output for positive currents, and U302-A and U302-B provide the output for negative output currents. The temperature range of 25° to 200° Centigrade provides an output of +10 to -10 volts at J200-12 (J200-14) with a corresponding output of -10 to +10 volts at J200-11 (J200-13).

2.5.3. Amplifier Disable

The protection circuitry is used to disable the amplifier on command. Line DA, when driven negative, drives all of the sections of U301 to disable the current mirrors that they power and thus disables all of the four output stages. The signal through D303 disables positive output currents, and the signal through D302 disables negative output currents. D305 is used to reduce the common mode input voltage to U301-A and U301-B. Without D305 an inverted output could exceed the amplifier's common mode input range. In the case of U301-C and U301-D, the output invoked by exceeding the common mode input range is identical to the desired output, and thus no problem. The outputs of the simulation signals are available for external analysis at T300 and T301.

2.5.4. Output Stage Fault

Should a failure occur that causes the output stages to conduct a large common mode current for more than a few microseconds, the amplifier will be disabled by the fault detection circuitry. The high side of the bridge is sampled by Q302 and Q303 to sense common mode currents. If the high side NPN stage is on, Q303 will be on. If the high side PNP stage is also on, Q302 will be on. When both Q303 and Q302 are on, a current will charge C300 across R302 and drive the opto-emitter of U303. This will trigger the SCR of U303 and latch the FAULT bar line low.

The low side of the bridge is sampled for common mode current by Q305 and Q306. The charging of C309 across R336 turns on Q304 which triggers U303 via the electrical gate input of the SCR. Whichever input triggers U303, the result is the same in that the control power supply which powers the SCR of U303 must be unpowered to unlatch U303 before operation of the main amplifier can be reattempted.

FAULTbar low places the amplifier in the standby state which removes power from the Vcc supplies and thus eliminates all potentially destructive current from the failed amplifier.

2.5.5. Thermal Protection Shutdown

U304 monitors thermal protection activity signals -LH and +LH. Under normal conditions, when thermal protection has not been activated, the output of U304-D is positive. If -LH goes positive or +LH goes negative, then pin 13 of U304-D will go low.

Until -LH or +LH change state, U304-D holds input pin 7 of U304-B high with R351 holding the input at +15 volts. The inverting input, pin 6 of U304-B, is connected to ground through R359. When the output of U304-D goes low, the current from R355 overcomes the current from R351, pulling pin 7 negative. When this happens, the hysteresis provided by D306 latches the output of U304-B low. To unlatch U304 pin 1, it is necessary to pull pin 6 low with U304-A. Pin 5 of U304-A is normally held high by U502 pin 7. When U502 pin 7 is pulled low by the overload reset signal, the output of U304-A goes negative, releasing U304-B from its latched state. C310 is used to reduce the recognition speed of the latch.

U304-C prevents U304-B from latching when the amplifier is disabled. When the amplifier is enabled, pin 9, the non-inverting input, is held negative, and the output, pin 14, is held negative. When the amplifier is disabled, the current from the output of U304-C overcomes any current from R352 and holds the input of U304-D low.

The output of U304-B is wired "OR" with the output of U501-B, so that either comparator will disable the amplifier and illuminate E501 (see Schematic J0298-0). If B10 is removed this circuit has no effect on amplifier operation.

2.6. STATUS AND INTERLOCK

2.6.1. Interlock

When multiple amplifiers are combined to form a larger amplifier, it is necessary to interlock the power controls of the units so that all of the units are powered simultaneously. Should one unit of a group not be enabled, it may be damaged by currents output from the other units.

The basic interlock system of the 8607 requires that the INT IN line be released from ground. The unpowered state of this line is conducting to ground through a depletion mode N-channel FET Q500. The gate of Q500 must be biased negative to open the drain to source channel.

The drains of all interlocked units will be pulled high by all of the R521s when all of the Q500s are off. The threshold for the enabling of the amplifiers is set to 10 volts, and each input is low-pass filtered by R520 and C502. D501 and D502 protect the inputs against transients and dissimilar AC potentials on the grounds of the interlocked units.

When INT IN goes high, the output of U501-D goes low, producing a current which lights the READY indicator E502 and enables the solid-state main power relays SS1- and SS2+, which switch the three phase power, to produce the Vcc supplies. R518 provides hysteresis of U501-D's switch point to insure a good trigger of the relays. Current limiting resistors are in both legs of the circuit, going to the relays for safety should an internal fault occur in the relays.

The gate voltage for Q500 is provided by U501-C. When the output of U501-C indicates that a chassis is ready, a current may be taken through R524 at INT OUT from INT COM. This would allow units that are not electrically common to ground to be interlocked with other units that are by using an optically isolated interlock.

2.6.2. Startup Delay

U501-C is driven from a timing network. When the unit is first powered, C504 is discharged and must be charged by current through R525. When the potential on C504 exceeds the ground potential on the hysteresis feedback divider of R523, R522 and R535, the output of U501-C will go low.

2.6.3. Hi Line Voltage

C504 may be discharged by three other detectors in the system. U501-A detects excessive line voltage as evidenced on the unregulated negative supply of the control supply. If this supply is too negative as determined by the setting of R512 used with R511 and R513, the output of U501-A will be held low. R516 going to the R535 tap of the hysteresis network of U501-C provides the needed hysteresis for this detector. The high voltage detector is set to disable the supplies at ten percent high line voltage. D511 is used to prevent a state at low line voltage in which the amplifier is disabled with ENABLE bar high but has the output of R512 above the signal from D500. C501 prevents ripple on the unregulated supply from toggling U501-A's output state. U501-A may also be signaled from the ENABLE bar signal through D500. When this line is high, U501-C's output will be low.

2.6.4. Fault

The FAULT bar line may also discharge C504 through D504. E505 and current supply resistor R529 indicate on the front panel if this state has been entered.

2.6.5. Overtemperature

C504 may be discharged by the overtemperature protection signal from U501-B through D503. If any one of the three coils of the three-phase main transformer, or one of the two high side heatsinks exceeds its allowed temperature limits, a thermal switch will open, and J400-19 will be disconnected from ground. R509 will pull up this line, and the signal through low pass filter R507 and C500 will overcome the current to the -15 supply through R508, and the output of U501-B will go low. E501, the high temperature front panel indicator, will also light. Since removing the power to the main supply does not defeat the cooling fans, the unit will cool down, the overheated switch will cool enough to close and power will be restored.

Any time that the unit is not in the ready state (but powered), the standby state will be occupied and indicated by E504. U500-C drives E504 and is controlled by the ready signal on the output of U501-D. The junction between E504 and its current limiting source resistor R530 is the DA line which is used to signal the protection circuitry to disable the amplifier. Therefore any time that the amplifier is in standby, it is also disabled in all power stages and the main supply, although some charge might momentarily remain on the Vcc supplies.

2.6.6. Overload

Should the amplifier be overdriven at any time, a large error signal will be produced at the output of U202 (signal A1). If this signal is greater than ten volts in magnitude, it may be safely assumed that some form of overload is in process. U500-A and U500-B function as window detectors to detect such a condition. The reference potentials for detection are supplied by R500, R501 and R502. If A1 signal is outside of this voltage window, the output of U500-A and U500-B will be low. U500-D is used to latch the output of the window detector.

Normally the input to U500-D from the window detector is high, with R504 holding the input at +15. The other input to U500-D is one diode potential above ground because Q501 is on and saturated. When the window detector drives the voltage at the junction of R503 and R504 negative with respect to the collector of Q501, the hysteresis of R505 to R504 is so large as to latch the

output of U500-D low. E500 will then be lit with the current flowing through R506. In order to release U500-D from this state, it is necessary to turn off Q501, allowing its collector to be pulled to -15 by R528. An output of this signal is taken through R540 to J300-14 to allow both a master and slave chassis to be cleared by the same signal from the master's Q501. Q501 is controlled by a current through R527 from U502. When no input is given to U502 (as in a slave chassis), the output is low and that Q501 is off. Note that whenever the standby state is entered, the output of U500-C will force U500-D to reset with the signal through D505.

The status of the amplifier is made available to the controlling computer by means of digital differential signals. READY, FAULT, OVERTEMP and OVLD status are all output. The ready signal from U501-D is coupled through Q502 and D506 to an RC network C506 and R531. These components delay the standby-to-ready transition status signal to allow the amplifier to be in full control after being enabled by the computer before it reports that it is ready. D507 prevents the input from being overdriven with positive voltage input. R531 and an internal undershoot diode protect from excessive negative inputs.

The input to the FAULT, OVERTEMP, and OVLD status outputs are all similarly protected with current limiting resistors and a diode for positive overdrive. Each of these outputs responds to the signal that drives the corresponding visual indicator on the front panel.

2.7. POWER SUPPLIES

The 8607 gradient amplifier has two classes of power supplies, control and Vcc. The control power supply provides low voltage to digital, small signal, standby and interlock circuits of the amplifier. The Vcc power supply drives only the output stage and uses a patented switching dual supply topology.

2.7.1. Control Power Supply

AC mains for control power originates at CB1. Control transformer T2 is a single phase transformer, whose primary is protected by CB2. The primary of T2 is used as an autotransformer to power the four, 120 volt fans. The secondaries of T2 are Faraday shielded and connect to full-wave rectifiers.

Unregulated supplies are produced by a full-wave center tapped winding using D400, D401, D405, D406, C402 and C404. From these supplies, U400 and U401 produce regulated +15 and -15 volt DC supplies. The ground of these supplies is considered to be an analog ground. Both of the regulated supplies have reverse polarity protection diodes D401 and D403. C403 and C405 are bypass capacitors for low impedance at high frequencies. The unregulated negative supply is used by the overvoltage detector of the status and interlock circuitry.

A second low voltage winding is used to drive a full wave bridge to produce the unregulated supply for a +5 volt IC regulator U402. Rectifiers D407-410 and C406 provide the necessary unregulated voltage. D404 provides reverse polarity protection. The ground of the +5 supply is considered to be a digital ground and is kept separate from the analog ground until they join in the vicinity of the DAC U120.

2.7.2. Vcc Power Supply

Grounded bridge amplifiers are capable of providing high voltage and large currents but not without large amounts of wasted power. The fundamental cause of this power loss is the excess available supply voltage (Vcc) on the output stages. In MRI applications, the need for high supply voltage is infrequent and results in poor system efficiency.

The Crown Patented BiLevel™ power supply reduces the dissipation losses across the output stages by changing the topology of the power supply. The BiLevel Vcc supply is built in two segments (V1 and V2) that switch between series and parallel topology to meet demands for high voltage or high current. Illustration 2-4 diagrams the current flow through the supply.

The implementation of the BiLevel uses multiple large-die FET transistors to switch V1 and V2. The switching is controlled by two comparators and a monostable timer. Additional components protect the FETs from abnormally high sustained current conditions.

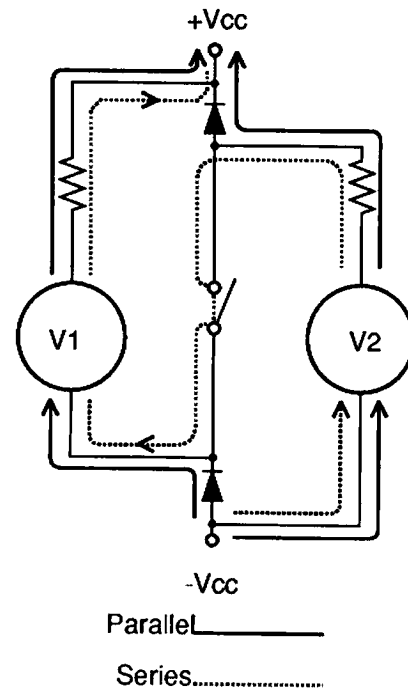

Illustration 2-4 BiLevel Current Flow

2.7.3 V1 and V2

Refer to Schematic J0300-4, 8607 BiLevel Power Supply, for the discussion of V1 and V2.

Upon entering the chassis, the three phase power passes through a three pole, high in-rush circuit breaker, CB1, which breaks all three legs of the AC mains.

Solid state relays K1 and K2, controlled from signals +SS1 to -SS2, provide primary power to T1's delta primary windings. Control signals +SS1 to -SS2 are internally optically isolated from the AC mains.

T1 has two matched "Y" secondaries which drive full-wave rectifiers. D417-D428 and C423 form supply V1. C417-C422 are high frequency bypass capacitors on the AC side of D417-D428. R400 is a bleeder to discharge C423 and C430 after power is removed. V2 is of identical construction using D429-D440 and associated capacitors. C431 provides local high frequency bypass for the output stage.

A normally closed thermal sensor is embedded in each of T1's three coils. These switches are wired in series and returned to the thermal protection section of the status and interlock circuitry. Like T2, T1 has a Faraday shield to prevent signals from V1 and V2 capacitively coupling to the AC mains.

2.7.4. BiLevel Local Power Supply

Refer to Schematic J 0320-2 for the discussion on BiLevel control.

D417 and D418 provide a local zener regulated power supply for the BiLevel control circuitry. R401 is a current limiting resistor with C419 providing power supply bypass.

The junction of D417's anode and D418's cathode provide a 6.2 volt reference to set the operating points of the various comparators within the BiLevel control circuit.

2.7.5. Switch Control

With small to moderate amplifier output voltages, supplies V1 and V2 are in parallel. They remain in parallel until large output voltage requirements cause the control circuit to switch to the series mode. V1 and V2 remain in series until the amplifier's output voltage drops to a level such that operation is possible in the parallel mode.

The two halves of U403 form identical comparators that monitor the available voltage of DC supply V2 and compare it to the output voltage of the amplifier. When a positive going output voltage exceeds a predetermined ratio of the available supply voltage, U403 pin 1 produces a low voltage triggering U404. When triggered, the "Q" output of U404 changes from low to high driving the gates of FETs Q400, Q401 and Q402. The other half of U403 (output on pin 7) reacts to negative going output voltage. Both halves of U403 receive V2 and amplifier output voltage differentially.

The time constant set by C418 and R416 on the input of U404 sets the maximum switch frequency of the supply. This time constant forces the supply to stay in the series mode regardless of amplifier condition for 200 S. The reset pin of U404 (pin 40) forces the output of U404 low when conditions exist that could damage the FET.

C416 and C417 provide hysteresis around the comparators of U405 to insure stable operation.

2.7.6 Protection

Protecting transistors conducting high current can be troublesome in circuits that do not have convenient current sample points. FET Q400-Q402 fall into this class of problems, but protection has been designed based on the following two conditions being present at the same time.

- Higher than normal on-state drain-to-source voltage
- Gate drive present

When both of the conditions exist, a reasonable assumption can be made that the FETs are operating in an area that, if sustained, will cause damage to the FETs. These two conditions are detected by U405 pin 7 and U405 pin 5.

U405 detects gate drive to the FETs at pin 7. Pin 6 is a reference input with the reference voltage set by R422 in series with R419.

U405 detects excessive source to drain voltage on the FETs at pin 5. R417 in series with R418 forms a voltage divider to input to pin 5 of U405. The reference is set by a voltage divider formed by R429, R420 and R422.

When both conditions are detected, the outputs of U405 (pins 1 and 2) allow C420 to start charging thru R423. After 20 S, C420 will be sufficiently charged to turn on the section of U405, whose output is pin 14, discharging C421. As C421 discharges, it turns on Q403, which pulls non-inverting input low (pin 9). U405 pin 13 drives the reset pin of U404 low which removes gate drive from the FETs. This hysteresis makes the circuit auto-resetting. Every 10mS (set by C421 and R426), the circuit will make another 20 S try at driving the FETs. R425 prevents Q403 from pulling the input of U405 below its negative supply.

2.8 SYSTEM THEORY

Two 8607 Gradient Amplifiers are connected in a push-pull configuration. This system configuration doubles the available voltage to the load.

Illustration 2-5 shows a simple system block diagram. The 16 bit digital input is applied only to the master amplifier. The output signal of the

master amplifier provides an input to the +1 and -1 inputs of the slave, driving the slave 180° out of phase. Thus the output of the master swings positive while the slave swings negative.

Illustration 2-6 shows the current flow through the output transistors for positive and negative waveforms.

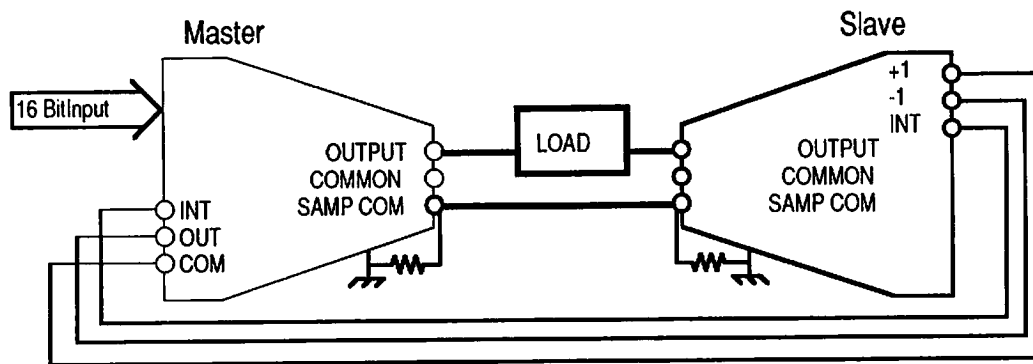

Illustration 2-5 System Block Diagram

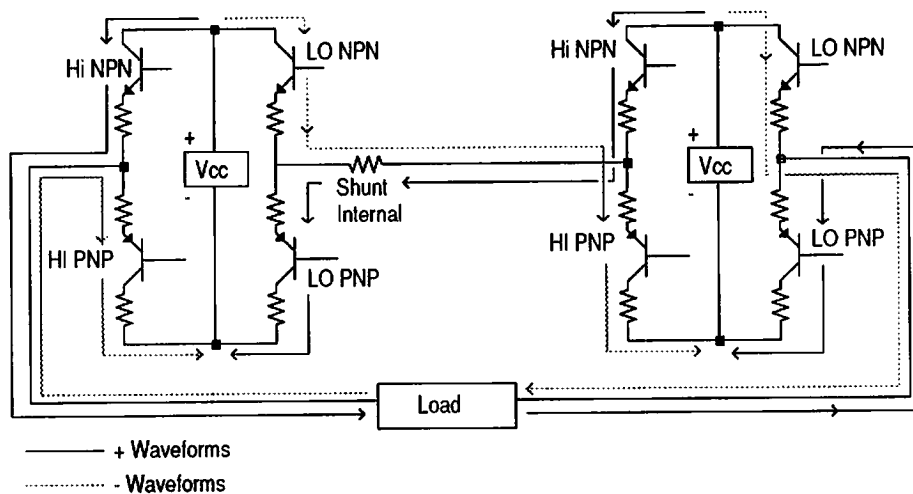

Illustration 2-6 System Current Flow

SECTION 3: TROUBLESHOOTING

3.1. INTRODUCTION TO TROUBLESHOOTING MODEL 8607

The procedures outlined in this section are limited to the identification and isolation of typical problems. This section will only be of value in the handling of gross component failures as distinct from intermittent malfunctions.

The procedures outlined in this section are directed to an experienced electronic technician. There is no attempt made to cover all of the many details involved in setting up and conducting typical electronic repair and test procedures. If components are replaced, refer to Section 3.17, Component Replacement, for instructions on required adjustments.

3.2. REPAIR PRECAUTIONS

Model 8607 undergoes periodic engineering updates. As a result, modules and electronic assemblies may not be fully interchangeable between units. Particularly, the main circuit board undergoes periodic engineering modifications which could effect an interchange of two main circuit boards between Model 8607's from different production lots.

The safest field repair procedure is replacement of an individual component, and this section is designed to aid the repair technician in isolating common problems down to the component level.

3.3. PREPARATION FOR TROUBLESHOOTING

WARNING!

Fatal electric shock hazard! These procedures are performed with unit under minimum 208 VAC power and with protective panels removed. Test steps must be followed precisely and technician must exercise extreme caution to avoid accidental touching of improper terminals or components. Powerful and potentially lethal electric shocks can occur as a result of accidental contact with capacitors, terminals, heatsinks and other interior components.

3.3.1. Equipment Requirements

In addition to standard hand tools and electronic test equipment, the following specialized equipment is recommended to perform the tests in this section. Using the equipment listed will help insure that Model 8607 can be tested and adjusted to factory specifications. Any compromises in equipment could result in a compromise in performance or calibration.

<p>Hewlett Packard HP 400F Voltmeter Tektronix 2215 Scope to observe waveforms Fluke 8060A DVM to measure voltage Wavetek Signal Generator 193 as signal source Intermodulation Analyzer to measure distortion Non metallic screwdriver for adjustments, GC 8276 or 8277 Current Shunt (Typical .005 ohms)</p>
--

Table 3-1 Recommended Equipment

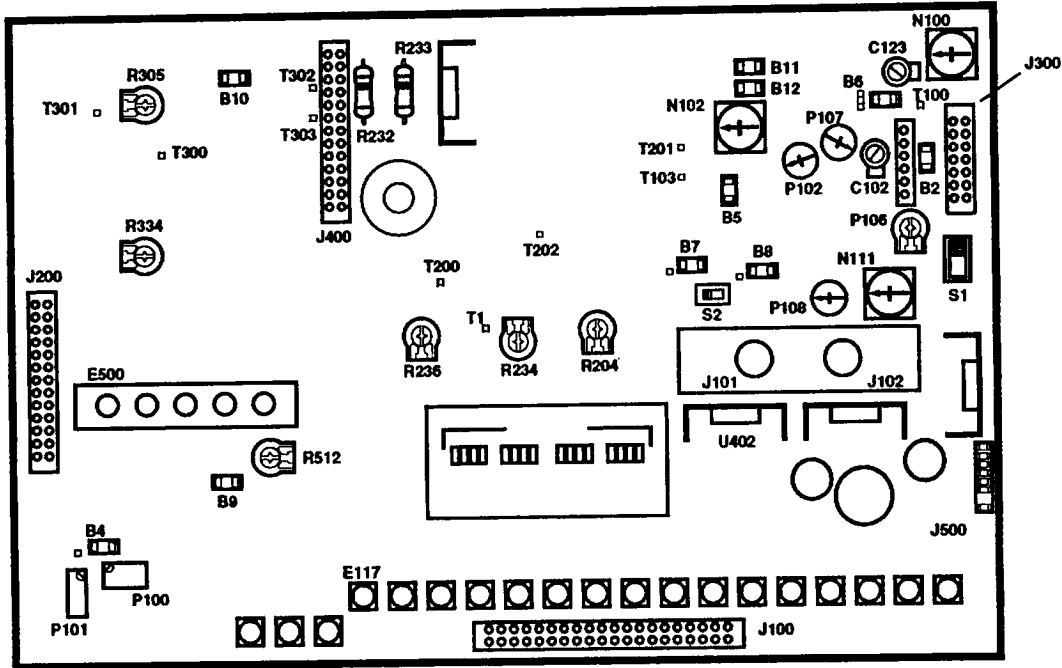

Illustration 3-1 Switch and Jumper Locations

Switch/ Jumper	Function	Position	Setting
B2	Eddy Current	Install Remove	Enable Disable
B4	Enable	Right Left Remove	Computer Control Manual Enable Manual Disable
B5	Current/Voltage	Up Down	Constant Current Constant Voltage
B7	Input Select	Right Left	Digital Analog
B8	Clipper Bypass	Install Remove	Disable Enable
B9	External Shim	Remove Install	Disable Enable
B10	Limiter Switch Enable	Remove Install	Disable Enable
B11	Current Monitor Gain	Remove Install	Off On
B12	Current Monitor Gain	Remove Install	Off On
S1	Master/Slave Switch	Up Down	Master Slave
S2	Shim In	Left Right Mid	Front Rear None

Table 3-2 Jumper and Switch Functions

3.3.2. Switch Settings

The following trouble shooting procedures will refer to several different switch settings. Table 3-2 and Illustration 3-1 describe the location and function of the settings.

3.3.3. Signal Source

Tests performed in following sections will require a 300Hz sinewave burst. This signal may come from a digital or analog input. Both set ups are shown in the next sections.

3.3.3.1. Analog Input

Connect an analog generator to J1 on the front panel. The male pin is positive. Set the 8607 and generator as shown in the tables below:

8607 Settings	
Switch/Jumper	Position
B7	Left
B5	Down
S1	Down
S2	Mid

Generator Settings	
Frequency	300Hz
Duty Cycle	20%
Repetition Rate	1Sec

Table 3-3 Test Settings

3.3.3.2. Digital Input

Set ATE to run a 300Hz sinewave burst on demand. Set the 8607 jumpers as shown below:

8607 Settings	
Switch/Jumper	Position
B7	Left
B5	Right
S1	Down
S2	Mid

3.4. MAKE THOROUGH VISUAL INSPECTION

Here is a check list of areas requiring a thorough physical inspection before powering up unit for testing:

1. Remove top, front, side and rear panels from unit.
2. Thoroughly inspect all modules for charring, breaks, deformation or other signs of physical damage.
3. Look for foreign objects that may be lodged inside the unit.
4. Inspect entire length of wires and ribbon cables to look for breaks or other indications of physical damage.
5. If the above visual inspection shows any physical damage, replace the defective parts before proceeding to the following troubleshooting procedures.

3.5. PREPARATION FOR TESTING UNDER POWER

The following series of troubleshooting tests are made with unit under power and with a load attached:

1. Disconnect system data cable from back of amplifier.
2. Connect a 0.5 ohm, .5 milliHenry load with positive lead at "Output" terminal and negative lead connected to "Sampled Common."
3. Connect input voltage of 208 VAC, 3 phase.

3.6. CHECK BY FUNCTION LIGHTS

This test will isolate problems using the function lights on the front panel. Refer to Illustration 3-2 for light functions.

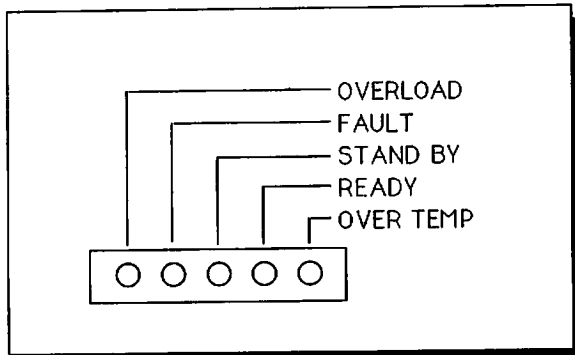

Illustration 3-2 Function Lights

1. Disable the amplifier by removing B4.
2. If unit is operating properly, the STANDBY and OVERLOAD indicators will both be on. All other indicator lights should be out.
3. If STANDBY does not light and the fans or other indicator lights are on, there is a problem in the STANDBY circuit. Proceed to Section 3.15.
4. Enable the amplifier by installing B4 in left position.
5. Verify that the READY indicator is on and that the OVERLOAD indicator goes off.
6. If both READY and OVERLOAD indicators are on, there is a defect on the main board. Proceed to Section 3.9.
7. If unit does not come out of STANDBY from Step 4 above, there are several possibilities:
 - a. If STANDBY remains lit and all of the indicators are off, proceed to Section 3.15.
 - b. If both STANDBY and OVERTEMP are lighted, perform tests from Sections 3.11 through 3.13.
 - c. If both STANDBY and FAULT are lighted, the problem is likely in the output stage. Proceed to Sections 3.7 and 3.8.

3.7. OUTPUT STAGE TEST

This test will help identify a defective output transistor which will be one of the more common causes of unit malfunction.

1. Turn AC power off.
2. Remove load wires.
3. Place red lead of ohm meter on heatsink of first output well and black lead on emitter bus strip of same well. See Illustration 3-3 for test points.
4. Test all four output wells in similar locations.
5. Compare ohm meter readings. All four readings should be very similar.
6. If meter reading on one well is lower than the others, that well contains a defective output transistor. Unsolder emitter resistors one at a time and check for shorts.
7. Replace any output transistor reading 0.66 ohms less resistance than others.
8. When testing output transistors, also test emitter resistor associated with each transistor.

Note: Resistors will either be operational or obviously defective. There is no "intermediate" level of function for these.

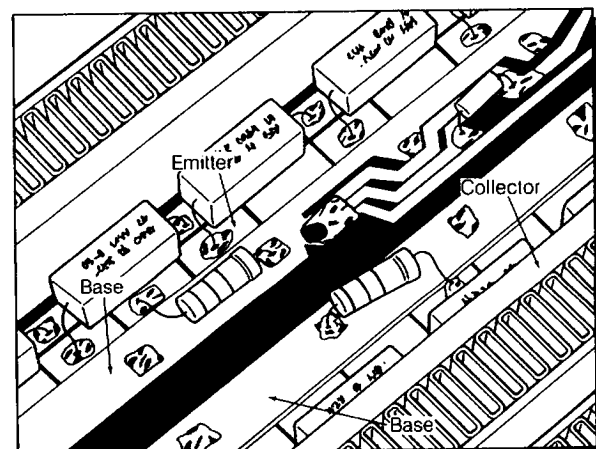

**Illustration 3-3
Output Transistor Test Points**

3.8. TEST DRIVER AND PREDRIVER TRANSISTORS

1. Test driver transistors. See Illustration 3-4 for test points.

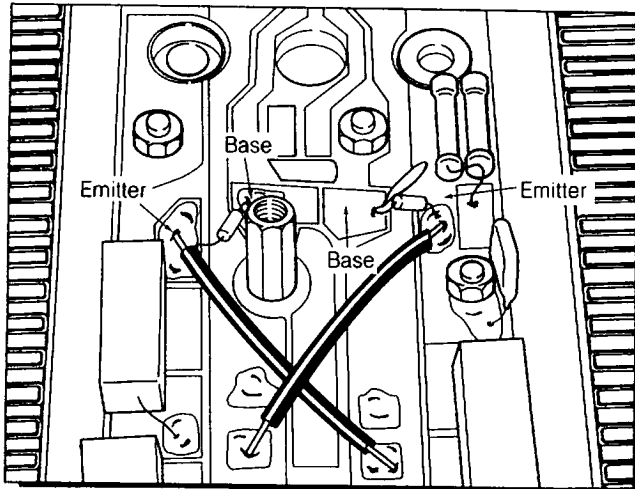

**Illustration 3-4
Driver Transistor Test Points**

2. Check predriver, a TO220 device, located on predriver board.

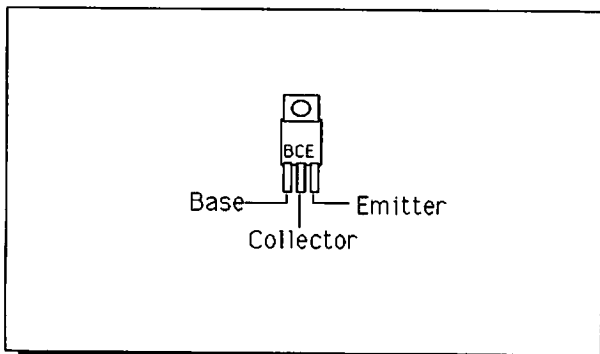

Illustration 3-5 Predriver Leads

3. When testing predriver, apply leads of ohm meter as follows:

- NPN wells (1 and 4): Red (+) on collector; Black (-) on emitter.
- PNP wells (2 and 3): Black (-) on collector; red (+) on emitter.

4. Readings for predrivers should show extremely high resistance.
5. If predriver shows low resistance, replace.
6. If predriver is replaced on well 1 or 4, check bias servo, TO92 device, glued onto heatsink next to predriver board.

Note: Leads of bias servo are arranged as follows: Emitter, Base, Collector, when looking at the flat side of the device.

3.9. ISOLATE MAIN BOARD PROBLEM

If previous tests were normal, the cause for a defective unit is likely on the main board. The following tests will aid in narrowing down the possible problem areas.

Set up for main board tests as follows:

1. Connect a load: 0.5 ohm, 0.5 milliHenry (as per previous test)
2. Set S1 up.
3. Start a 300 Hz toneburst.
4. Connect scope to T100 and ground.
5. There are several possible signal results from this test. Proceed to subsequent tests based upon the following schedule:

- Properly formed sinewave, no apparent input malfunction. Check U128B, U130. Check components in Gain Stage schematic numbers 200.
- No signal or distorted: check U120, U121, U122 if digital input. Check U126, U127-A, or U128-A.
- Oscillations or other problems could result from various causes. Make erratic waveforms test from Section 3.10.

3.10. CHECK OUTPUT WAVEFORM OSCILLATIONS

This test may be conducted if the test results of Section 3.7 and 3.8 were oscillations at test point T100. Proper conduct of the test requires a solid familiarity with Model 8607 schematics and high proficiency with electronic test procedures.

1. Attach a scope probe to T201.
2. Start a 300 Hz tone burst, 20% duty cycle, at J1 and slowly raise the input voltage until an error signal is seen on T201.
3. Look for spurious responses up to clipping.
4. Capacitors and resistors marked as selectable on the output stage schematic may be selected within limits to keep T201 clean up to clipping.

The previous tests and checks have examined for the more common problems in the output section and the gain stage of the Main Board. If all of the previous tests have proven inconclusive, the following three troubleshooting tests should be conducted.

3.11. CHECK FOR DEFECTIVE THERMAL SWITCH OR THERMAL SWITCH WIRING

To check for a defective thermal switch or associated wiring flaws, consult wiring diagram and perform a continuity test through the thermal switch wiring path. An OVERTEMP condition places the amplifier in STANDBY. If the OVERTEMP pulse is extremely short, as it would be in the case of defective wiring or switches, the OVERTEMP pulse may be too brief to see. Since the return to READY is automatic after any OVERTEMP condition is over, the READY light will return. Thus, the signal STANDBY alternating with READY for no apparent reason could indicate a possible defect in thermal switches or their wiring.

3.12. CHECK FOR INADEQUATE COOLING AIR FLOW

1. With power ON, visually inspect fans for correct operation.
2. Replace any fan not operating, operating at reduced speed, or running backwards. (Air flow must go inward at fans, and outward from front panel grille. If a replacement fan is defective, it might run backwards.)

3.13. CHECK FOR OVERHEATING OF INDIVIDUAL OUTPUT WELL

WARNING!

Fatal electric shock hazard! Do not touch output wells. Heatsinks carry electrical current and may be hot. Serious burns or electric shock may result.

1. Turn ON circuit breakers on the rear of the amplifier.
2. Allow output well to heat up.
3. Turn OFF circuit breakers.
4. Place hand NEAR (do not touch) output wells, one at a time.
5. Test any output well which is substantially hotter than others.
6. See Section 4 for instructions on servicing of output well components.

3.14. INTERLOCK AND STANDBY

Operation of the interlock and standby circuit is described in Section 2.6, Status and Interlock.

Here are four sources of standby problems.

1. U500, U501, Q500 failure.
2. An open temperature switch circuit. Check switch continuity in main transformer and on heatsinks.
3. High mains voltage. Check that AC mains are 208 nominal.
4. Enable jumper B4 not positioned properly.
 - Right for external computer control
 - Left for manual enable
 - Remove for manual disable

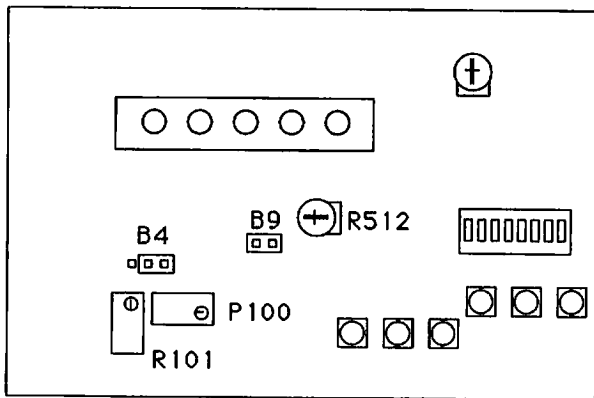

Illustration 3-6 B4 Location

3.15. BILEVEL POWER SUPPLY TESTING

Test the BiLevel for faulty parts when the power supply fails to switch into the series mode. Testing the ICs and transistors found in table 3-4 will resolve most failures.

IC	Type	Test/Activity
U404	CMOS Timer	Substitute
Q400-Q402	FET	Check with ohm meter
U405	Comparator	Check with ohm meter
U403	Comparator	Substitute

Table 3-4 Bilevel Power Supply Testing

3.15.1. In Circuit Test for Shorted FET Switch

1. Turn amplifier upside down.
2. Remove bottom and back cover. See Section 4.
3. Slide output shelf to the rear until the BiLevel control board is exposed.
4. Measure resistance from wires -V2 to +V1, +V1 to G, and G to -V2 with an ohmmeter. A reading of less than 100 ohms on any one of the three readings indicates a shorted FET. Perform test to find individual shorted test.

3.15.2. Individual FET Switch Test

1. Remove the output shelf from the amplifier. Refer to Section 4.6, Service of Output Shelf Components, for exact procedure.
2. Unsolder the gate and source bus bars from the FET pins.
3. Connect an ohmmeter between gate to source, source to drain, and drain to gate on all FETs. See Illustration 3-16 for location of FET pins. Replace any FET with reading less than 200 ohms.

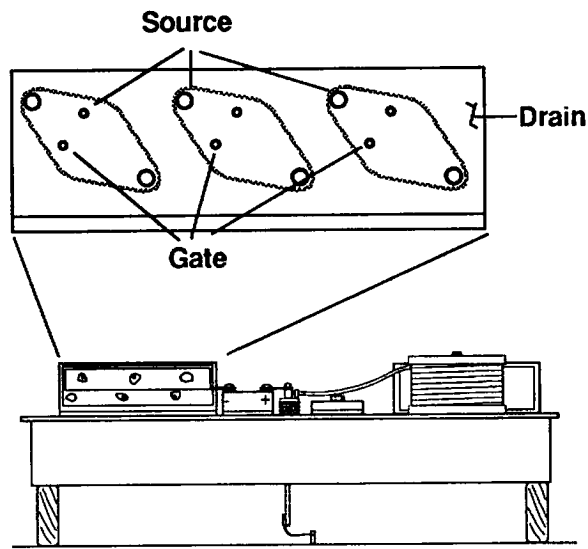

Illustration 3-7 FET Pins

3.15.3. Test for defective U405

Connect an ohmmeter across C420. Resistance less than 100 ohms indicates U405 is defective.

3.15.4. Test for Defective Q403

Connect ohmmeter to Q403 between Base to Emitter, Emitter to Collector and Collector to Base. Replace Q403 if any reading is below 100 ohms.

3.16. COMPONENT REPLACEMENT

If any of the preceding tests resulted in component replacement, refer to Section 5, Testing and Adjustment. If it is not practical to run the complete Testing and Adjustment procedure, an alternative would be to check only those adjustments related to specific components. Refer to Section 5.15, Component Interaction List.

3.17 RESTORATION FOLLOWING TROUBLE SHOOTING

Restore amplifier by performing procedures in Section 5.14, Restoration.

SECTION 4: DISASSEMBLY AND ASSEMBLY

Note: "Item" numbers used in this section refer to the key number used in Illustration 7-1. Illustration 7-1 is the master exploded-view assembly drawing of Model 8607. Fasteners, wiring paths, and the relative positions of modules can be determined from an inspection of this illustration.

WARNING!

Fatal electric shock hazard! Model 8607 carries potentially lethal voltages even after the main power supply has been disconnected. After power shutoff, and before any service procedure, wait at least two minutes for automatic capacitor to discharge. Verify the discharge by testing the capacitor terminals or rectifier blocks.

4.1. INTRODUCTION TO DISASSEMBLY AND ASSEMBLY

Illustration 7-1 is the master exploded-view assembly drawing that shows the relationship of modules and assemblies.

This section has two purposes:

- To review important safety information for the protection of both equipment and servicing personnel.
- To identify several assembly and disassembly procedures that might not be apparent from a study of Illustration 7-1.

4.2. IMPORTANT SAFETY INFORMATION

4.2.1. Introduction

Model 8607 operates from 208 VAC, 3-phase mains. In addition to physical hazards to servicing personnel, certain electrical conditions could cause damage to component parts.

4.2.2. Disconnecting Power Supply and Discharging Capacitors

Before attempting any servicing of Model 8607, shut down the outside power supply as follows :

1. Turn OFF the power at CB1 (Rear Circuit Breaker, Item 59 on Illustration 7-1) to service the amplifier and its paired master/slave amplifier
2. Disconnect the AC main plug from the rear of each unit.

Note: The rear Circuit Breaker (CB1) may be used to temporarily shut down the power unit. However, disconnecting the plug provides an extra measure of safety to the service technician.

3. Wait two minutes for capacitors to discharge before touching any part of the amplifier.
4. Remove the single screw (Item 24 on Illustration 7-1) on the rear cover.
5. Remove the bottom cover (Item 23 on Illustration 7-1) to expose the power supply capacitors.
6. Verify the capacitor discharge by connecting a voltmeter across the "+" and "-" terminals of the power supply capacitors (two places). Illustration 4-1 shows the test points.
7. Verify a reading of less than 50 volts before proceeding.

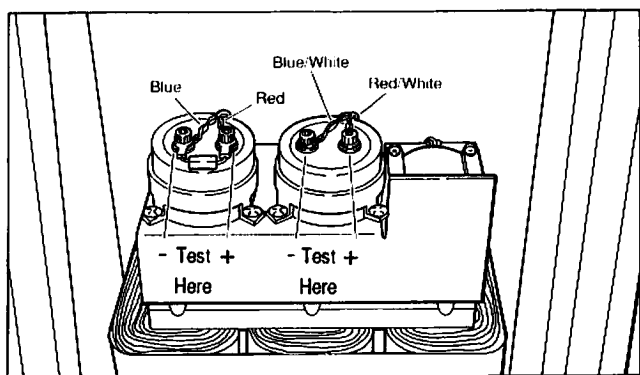

Illustration 4-1 Capacitor Test Points

4.2.3. Floating Ground

The internal electrical components of Model 8607 are not grounded to the chassis. Because of this floating ground feature, test equipment used in servicing Model 8607 should not be earth-grounded. There is a possibility of erroneous readings occurring from the use of grounded test equipment. Use an isolation transformer to float the test equipment from an earth ground.

4.3. REMOVING AND INSTALLING IN A CABINET

Removing an 8607 from a cabinet requires removing all connections from the back panel as well as removing the amplifier from the cabinet. Before removing connections to the amplifier, carefully note the locations of all wires and cables. System connections are not covered in this manual.

WARNING!

Tip hazard! Do not pull more than two 8607 amplifiers forward at one time. The cabinet will become unbalanced and tip forward with more than two 8607 amplifiers pulled forward.

WARNING!

Fatal electric shock hazard! Disconnect the AC mains from the cabinet before removing or installing an 8607. Electrocution or electrical burns may result from contact with uninsulated terminals inside the cabinet.

To remove the amplifier:

1. Remove the four mounting bolts on each side of the unit.
2. Remove all wires and cables from the back of the amplifier.
3. Retain resistor from output terminal to chassis ground.
4. Pull the amplifier straight out from the cabinet until the slide reaches the stops.

WARNING!

This amplifier is too heavy for one person! Support the amplifier with a lift device to remove.

4. Release the amplifier from the slide rails.
5. Pull the amplifier straight out until the two halves of the slide rails disengage.
6. Place the amplifier on a table or bench top for service.
7. Remove eddy current board if a master amplifier and retain for replacement amplifier.

To install the amplifier:

1. Support the amplifier with a lift device.
2. Pull the slide rails out of the cabinet until they reach maximum extension.
3. Position the amplifier to engage the slide rails. Push the amplifier into the cabinet until the slide rails reach the stops.
4. Release the slide rail stops and push the amplifier all the way back into the cabinet.
5. Reattach the cables and wires to the back of the amplifier.
6. Install 2.7 ohm resistor from sampled common to chassis ground on a new master gradient amplifier.
7. Install 2.7 ohm resistor from common to chassis ground on a new slave.
8. Secure the amplifier front panel with eight screws, four on each side.

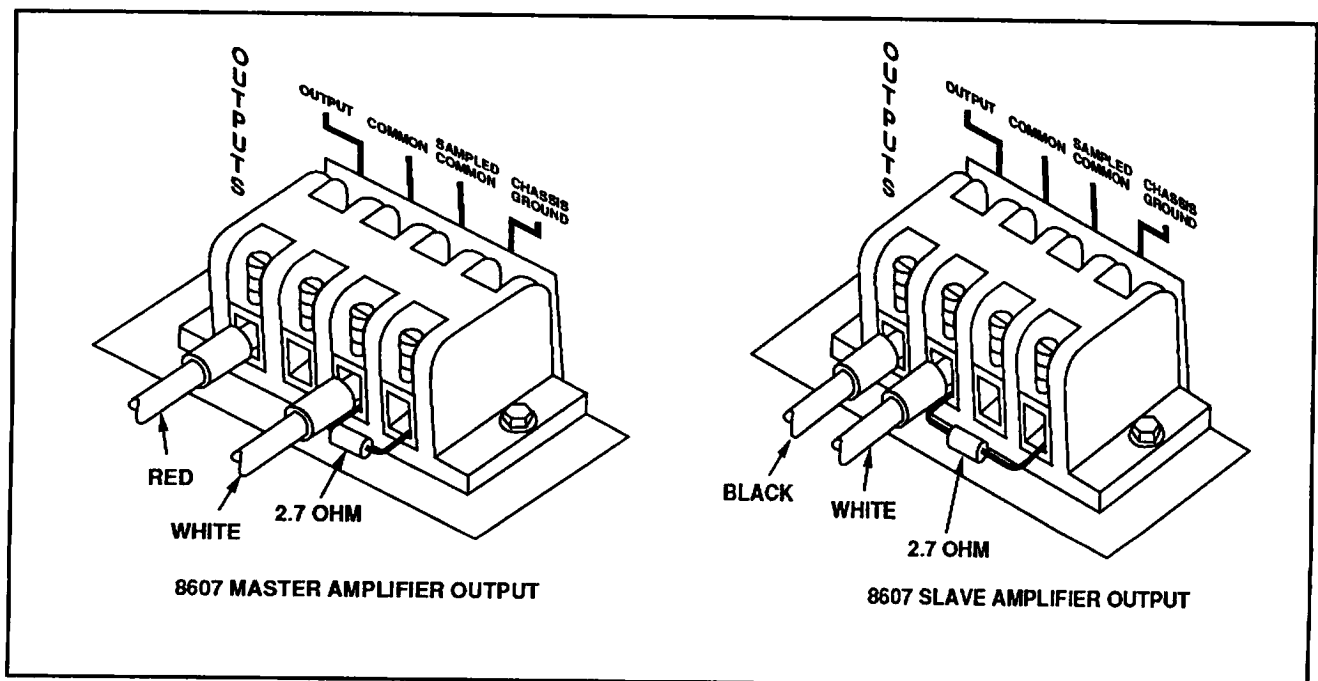

Illustration 4-2 8607 Amplifier Output Wiring

4.4. FRONT PANEL REMOVAL

Note: "Item" numbers used in this section refer to the key number used in Illustration 7-1. Illustration 7-1 is the master exploded-view assembly drawing of Model 8607. Fasteners, wiring paths, and the relative positions of modules can be determined from an inspection of this illustration.

Loosen four screws until cover can be removed. Be sure retaining washers do not fall off.

CAUTION

Ribbon cables and other connections will be damaged if they are pinched when replacing the front panel. Position all cables away from the edges of the front panel before securing the front panel.

4.5. REMOVAL OF REAR, TOP, BOTTOM, AND SIDE PANELS

The front, top and bottom panels can be removed independently. The fan covers can also be removed individually.

WARNING!

Electric shock hazard! After panels are removed, make sure capacitors are allowed to discharge before proceeding with any further service.

4.6. SERVICE OF OUTPUT SHELF COMPONENTS

The output shelf (Item 64) is a frame that holds the four output wells. Removal of the output shelf is not needed to service the output wells. Remove the output shelf to service components mounted underneath the shelf.

To remove the output shelf:

1. Disable the amplifier by performing the shutdown procedures covered in Section 4.2.2.
2. Remove the output wires to the load from the output terminals at the rear of the unit. Label the wires to ensure proper connection after servicing.
3. Using a long arm 3/16" allen wrench, unscrew and remove the red, blue, red/white, blue/white wires from the capacitor terminals (Illustration 4-7 shows reassembly sequence). Replace and finger-tighten the socket cap screws to hold the terminals with multiple wires in place.
4. Disconnect the in-line connections in the two gray wires. See Illustration 4-3. These wires are interchangeable and can be reconnected to either connector.

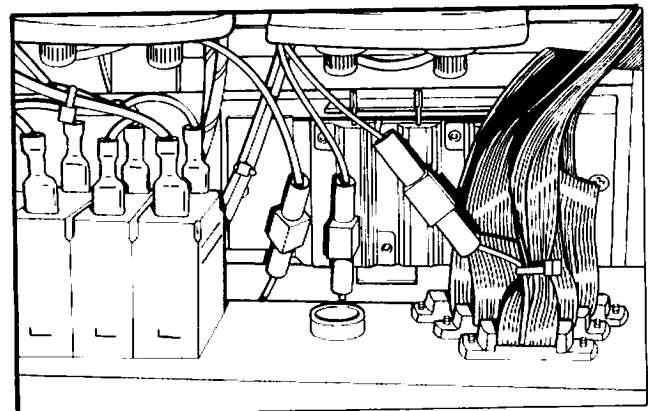

Illustration 4-3
Output Shelf In-line Connections

5. Disconnect the remaining in-line connections from J300 ribbon cable. Note: mark wires and reconnect to same connections.
6. Disconnect the output interconnect board from the Main Circuit Board. See Illustration 4-4.
7. Remove the back panel (Item 60).

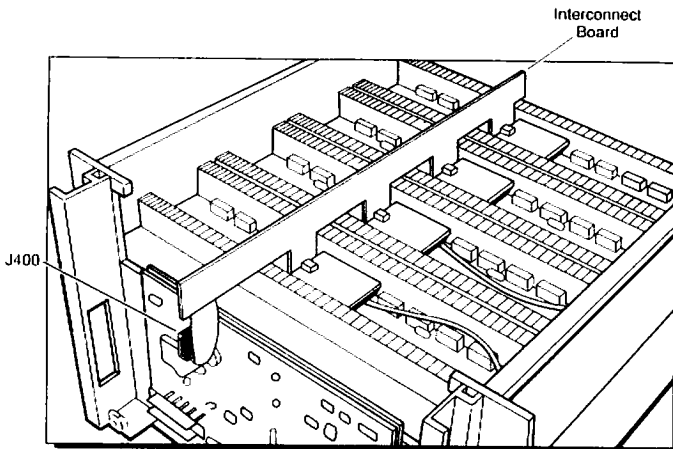

Illustration 4-4 Interconnect Board

CAUTION

Be prepared to place the output shelf on blocks before removing it from the amplifier. See Illustration 4-5.

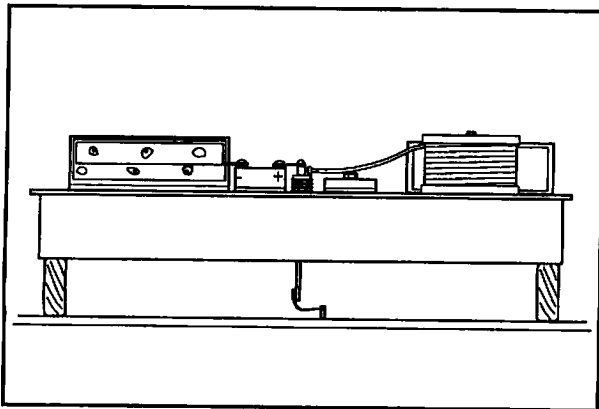

Illustration 4-5 Support the Output Shelf

8. Remove the output shelf assembly (Item 64) from the rear of the unit. Carefully feed loose wires past back panel as shelf assembly is removed. Place the shelf on blocks to prevent damage to the components. See Illustration 4-6.

Proceed to the appropriate section for individual component service.

To install the output shelf assembly:

1. Slide the output shelf assembly (Item 64) into lower of two slots in chassis. See Illustration 4-6). Make sure that the interconnect board is not damaged as the shelf and front panel come together.

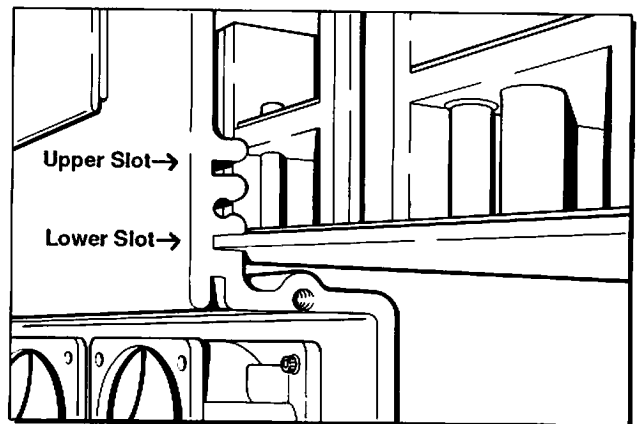

Illustration 4-6 Output Shelf Positioning

2. Replace the back panel . (Item 60)
3. Reconnect the interconnect board to J400 on the Main Circuit Board.
4. Reconnect the two gray wires with the in-line connectors.

Note: The gray wires are interchangeable and may be connected to either connector.

5. Reconnect the in-line from J300.
6. Reconnect the wires and bleeder resistor to the terminals on the capacitors. Connect red on red, blue on blue, etc. See Illustration 4-7.

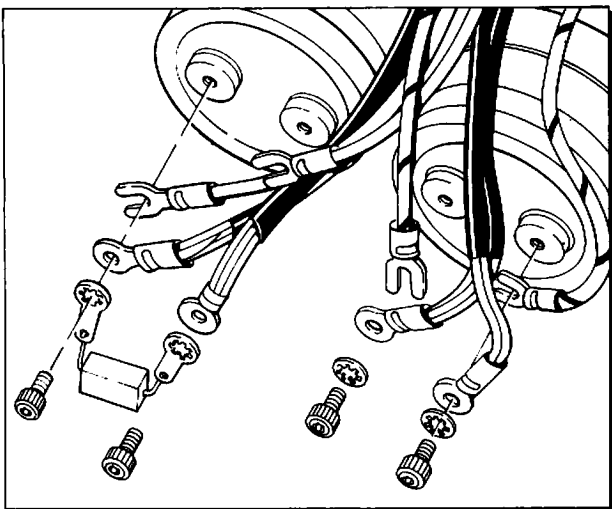

Illustration 4-7
Capacitor Terminal Assembly

CAUTION

Finger-tightening of (socket cap) screws to the capacitor terminals will result in loose connections that will overheat. Use a 3/16" long arm allen wrench to securely tighten screws.

7. Tighten the socket cap screws with an allenwrench.

4.6.1. Flyback Diode Block, D607

(See Item 3 on Illustration 7-2; also see Illustration 4-8.)

To remove:

1. Note and mark the wiring connections on the Flyback Diode Block. (See Illustration 4-8.)
2. Unplug the brown and black wires.
3. Unsolder the red and blue wires.
4. Remove the mounting nut and washer from the captive mounting stud.
5. Remove Flyback Diode Block.

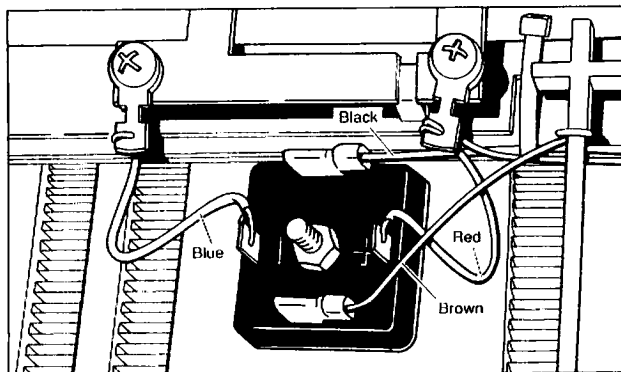

Illustration 4-8 Flyback Diode Block Detail

To install:

1. Apply heatsink compound lightly, but completely to the Flyback Diode Block mounting surface.
2. Install and tighten the washer and mounting nut.
3. Solder the red and blue wires.
4. Connect the brown and black wires.

4.6.2. Current Sampling Resistor Assembly

The Current Sampling Resistor Assembly consists of upper and lower plates that hold six parallel resistors. See Items 20 and 22 on Illustration 7-2. The individual resistors are not rewireable. If one resistor is found to be defective, you must replace the complete upper or lower group. Also, whenever one of the resistor groups is replaced, you must also replace the rubber grommets (Item 28) that will likely be damaged during the removal steps.

To remove the current sampling resistor assembly as a unit:

1. Remove the two large phillips screws on the base plate.
2. Unsolder the orange and black wires from the bus bars. Use a 175-200 watt soldering iron.

To install:

1. Replace rubber grommets.
2. Install a new current sampling resistor assembly.
3. Orange and black wires pass through holes in the bus bar and are secured with heavy solder. Duplicate this soldering method when replacing these wires.

4.6.3. Servicing Bus Bar Assembly

The bus bar assembly includes four copper bus bars with insulation material between them. The individual bus bar assembly components are replaceable when removed from the output shelf. See Illustration 7-2 for details on the bus bar assembly.

Should the insulation between individual bus bars require replacement, use only the original equipment insulating material.

WARNING!

Substituting insulating material other than the original specification may result in unsafe or unstable operation of the amplifier. Order replacement insulation from TECHRON. See Renewal Parts list.

4.6.4. Foam Insulation

Foam insulation between the heatsinks and output shelf serves as a gasket for cooling air. A gasket which is damaged or removed during a service procedure must be replaced. Order replacement gasket material from TECHRON only.

4.6.5. FET Switch Service

All "Item" numbers in this section refer to Illustration 7-2.

Removal:

1. Each FET switch (Item 35) is connected to a copper bus bar and a PC board. Unsolder the FET from both places.
2. Remove the FET mounting screws.
3. Loosen the leads then remove the faulty transistor.

Replacement:

1. Replace the transistor with one having the same part number.
2. Apply heatsink compound (See Renewal Parts List.) to the surface of the replacement transistor. Apply compound lightly, but completely so that only a small amount will be squeezed out when the transistor screws are tightened.
3. Install the mounting screws. Tighten the mounting screws before resoldering the leads. Torque to 11 in·lb (+2 in·lb).

CAUTION

Tightening the transistor mounting screws after the leads are soldered will break the internal transistor connections. Solder the transistor leads after the screws are tight.

4. Solder the leads to the bus bar (Item 29) and PC board.

4.6.6. Control Board Service

The power supply control board is mounted underneath the output shelf. See Illustration 7-2, Item 7.

To remove:

1. Lift up on the control board (Item 7) to remove it from the mounting pins. A slight front-to-back rocking motion will assist in the removal.
2. Carefully position the board in a vertical position to gain access to both sides of the board for service.
3. Use a solder removing tool to remove solder from the holes in the board before removing the components.

CAUTION

The holes in the control board are plated. If the solder is not completely removed from the hole before the component is pulled out, damage to the board will result.

To install:

1. Position the board directly over the three mounting pins.
2. Push straight down on the mounting pins until the board is seated on the shoulder of the pins.

4.6.7. Bridge Diode Replacement

All "Item" numbers in this section refer to Illustration 7-2.

To remove:

1. Remove the two screws from the top of the diode that holds the switch bus bars.
2. Remove the screws (Item 40) that connect the switch bus bars to the Vcc bus bars.
3. Shift the position of the switch bus bars (Items 42 and 43) slightly to one side or the other to reach the diode mounting screws (Item 47).
4. Remove the diode mounting screws.
5. Slide the defective diode sideways to remove.

To replace:

1. Apply heatsink compound (see Renewal Parts list) to the surface of the replacement diode. Apply the compound lightly, but completely, so that only a small amount will be squeezed out when the transistor screws are tightened.
2. Position the replacement diode over its mounting holes. The "+" end of the diode is towards the bus bars.
3. Replace the mounting screws and washers.

4.6.8. Termination Board Service (Item 39)**CAUTION**

Prolonged heat applied to the termination PC board will cause damage to the board materials. Use a large wattage (500 watts) soldering iron for these procedures. A smaller iron will extend the period of time needed to heat the copper bus bars and will damage the PC board.

To remove:

1. Remove the solder from the two points on each end of the termination PC board where it is soldered to the bus bar. See Illustration 4-10.
2. Carefully position the board to gain access to the components mounted on it.

To install:

1. Position the board over the two mounting prongs on the copper bus bars.
2. Use a 500 watt (or larger) soldering iron to quickly solder the board to the copper bus bar.

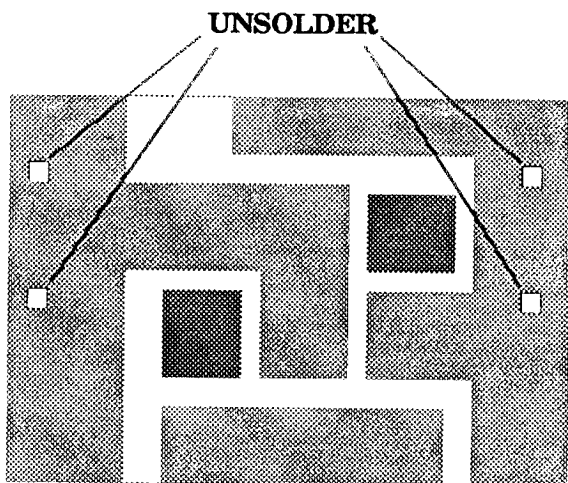

Illustration 4-9
Termination Board Solder Points

4.7. SERVICING FANS

Model 8607 includes four fans (Illustration 7-1, Item 41) that provide a flow of outside air through the heatsinks. Internal heat protection will shut down the amplifier if the cooling from the fans is insufficient to dissipate heat. The fans are interchangeable with each other, but not repairable. Defective or inoperative fans must be replaced.

The following instructions describe replacing a fan on one side only. The procedure is identical for all four fans.

WARNING!

Fatal electric shock hazard! Verify capacitor discharge (see Section 4.2.2.) before servicing fans.

To remove the fans:

1. Disable the amplifier by performing shut down procedures as covered in Section 4.2.2.
2. Remove the single screw (Item 24) on the rear panel to loosen the fan side panel (Item 46).
3. Slide the fan side panel out.
4. Remove the four socket cap machine screws (Item 40) holding each fan in position.
5. Remove the wire connectors for the appropriate fan. Illustration 4-10 shows the relationship between the fans and the connectors. The front pair of connectors power the front fan. The rear pair of connectors power the rear fan.

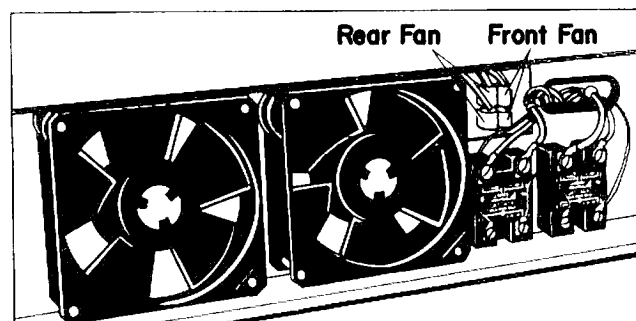

Illustration 4-10 Fan Connector Matching

To install a new fan:

1. Connect the wire terminals as shown in Illustration 4-10.
2. Make sure that the air flow directional arrow on the fan case points into the center of the unit.
3. With the fan in position, insert and tighten the screws (Item 40) at each corner.
4. Slide in the fan side panel (Item 46). Fasten the cover with a single screw (Item 24) through the rear panel.

4.8. POWER SUPPLY RECTIFIER BLOCKS

See Item 38, Illustration 7-1; also see Illustration 4-11.

To remove:

1. Disable the amplifier by performing procedures in Section 4.2.2.
2. Remove right side panel by removing one screw from rear cover.
3. Remove the wires.
4. Remove the phillips mounting screw. The nut is captive.

To install:

1. Solder two .1 MF capacitors in place on the new rectifier. (Refer to C417 through C422 and C424 through C429 on schematic.)
2. Apply heatsink compound to the block mounting surface.
3. Install the mounting screw (Item 34).
4. Reattach the wires as shown in Illustration 4-11. Each block has two interchangeable wires of the same color along with a red (+) and blue (-).
5. Slide right side fan panel in place and secure with one screw in rear cover.

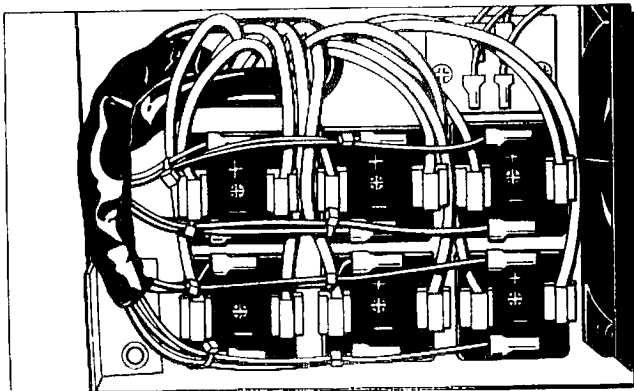

Illustration 4-11
Power Supply Rectifier Block

4.9. SOLID STATE RELAYS

(See Item 3 on Illustration 7-1.)

To remove:

1. Disable the amplifier by performing procedures of Section 4.2.2.
2. Remove left side fan panel (Item 46) by removing one screw (Item 70) from rear cover.
3. Disconnect the wiring at the screw terminals.
4. Remove the two mounting bolts from the solid state relay. The nuts inside are captive.

To install:

1. Apply heatsink compound lightly, but completely to the mounting surface of the solid state relay.
2. Mount the relays in place on the side panel.
3. Reattach the wires and filter capacitors.
4. Slide left side fan panel in place and secure with one screw in rear cover.

4.10. RIBBON CABLES SERVING J100, J200, AND J300

Before removing the ribbon cables, note their routing. Reinstall the ribbon cables according to the original routing.

To remove:

1. For proper access to ribbon cables, you must remove front, bottom, and rear panels. See Sections 4.4 and 4.5.
2. Slide output shelf back about 4 inches to allow cables to route over transformer.
3. Detach from front panel terminals.

To install:

1. Route cables in same manner as original placement.
2. Reassemble output shelf and exterior panels.

4.11. SERVICING MAIN CIRCUIT BOARD

See Illustration 4-12.

CAUTION

The holes in the Main Board are plated through. Use caution and good solder removal methods to avoid damage to the plating in the holes.

CAUTION

Static sensitive components! Once the ribbon cables, output board connector, and power supplies are disconnected, the Main Circuit Board is no longer protected against static electricity. Service the Main Circuit Board in a static-free environment. Wear wrist static straps to guard against damage to the Main Circuit Board.

Removal of the Main Circuit Board (Item 12 on Illustration 7-1) requires disconnection of the ribbon cables and output board connector, disconnection of the main power supply, and removal of the four mounting screws.

Service the Main Board components in accord with the standard PC board procedures. Use an IC extractor to avoid damaging these components.

To remove:

1. Disable the amplifier by performing procedures of Section 4.2.2.
2. Remove the front panel. (See Section 4.4 for precautions on front panel removal and replacement.)
3. Using ejector latches, disconnect the ribbon cable from J100, J200, and J300, and disconnect the output connector from J400.

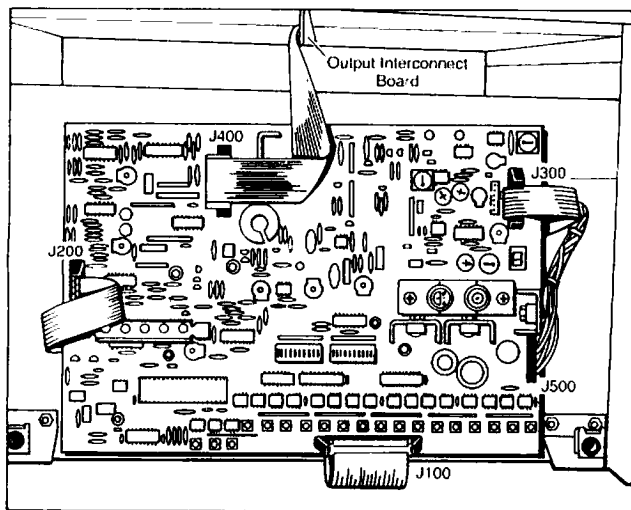

Illustration 4-12
Main Circuit Board Connections

4. Disconnect the power supply from the terminal J500 on the right side of circuit board.
5. After power supply is removed, inspect the pins of terminal J500 and straighten any that may have become bent.

Note: Some versions of Model 8607 use a nylon washer on one or more Main Circuit Board mounting screws. Note the position of the washer for replacement.

6. Remove the four mounting screws from the Main Board.
7. The Main Circuit Board and gray insulating panel (Item 13) can now be lifted off.

To install:

1. Place the gray insulator panel (Item 13) over the mounting holes.
2. Place the Main Circuit Board (Item 12) in position and attach it with four black nylon mounting screws.
3. Connect the power supply cables at J500 taking care to protect the connecting pins.
4. Connect the ribbon cable to J100, J200, and J300, and the output connector to J400. Note that the ribbon cable makes a "U-turn" over the connector. Further, note that the connections will only fit in the correct location and only in the correct orientation. Only slight force should be needed to connect each of these connections. See Illustration 4-13.
5. If used, reattach the nylon washers on one or more mounting screws.
6. Refer to Section 5, Testing and Adjustment, for the procedures to follow after the replacement of the Main Circuit Board.

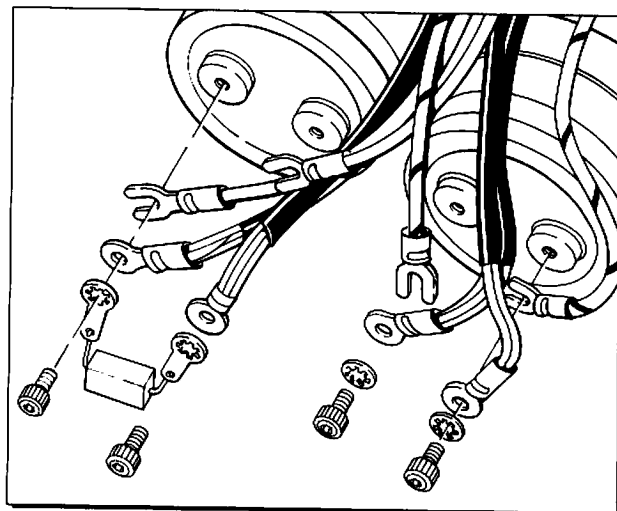

Illustration 4-13
Capacitor Terminal Assembly

4.12. SERVICING POWER SUPPLY COMPONENTS

Note: All "Item" references are from Illustration 7-3.

The power supply components include: two capacitors (Item 4), a low voltage control transformer (Item 11) and a power transformer (Item 21).

WARNING!

Before servicing any power supply components, disconnect the power by removing the incoming power line. It is essential that the capacitors be allowed to discharge before proceeding to any service work on the power supply components. Follow the safety shutdown steps as explained in Section 4.2.2.

To service the power supply components:

1. Disable the amplifier by performing shutdown procedures of Section 4.2.2.
2. Remove the top and the bottom panels. See Section 4.5.
3. Remove the output shelf assembly to provide access to the power supply components. See Section 4.6.

4.12.1. Removal of Capacitors and Control Transformers

1. Remove the mounting bracket (Item 12), which is held in position by three 1/4-20 x 2-1/2 capscrews (Item 14).

Note: In removing the capscrews, take care to retain the shoulder washers that insulate the mounting bolts from the bracket. There are six shoulder washers (Item 15), three on each side of the mounting bracket.

2. With the capscrews removed, the entire bracket with the capacitors and control transformer attached can be removed through the bottom of the unit.

4.12.2. Servicing of Capacitors

Each capacitor (Item 4) is attached to the mounting bracket (Item 12) with a capacitor mounting bracket (Item 3). A bleeder resistor (Item 7) bridges the positive and negative terminals of the left capacitor.

CAUTION

The outer surface of the capacitors can be damaged by scraping or scratching. Protect the cylindrical surface from scratches, particularly when removing and inserting the capacitors in the compression ring.

To remove the capacitors:

1. Verify the discharge by connecting the capacitor terminals with a voltmeter. The voltmeter should show a zero reading.
2. Remove the socket capscrews (Item 5) with a long arm, 3/16" allen wrench.
3. Remove the wires, noting the mounting location for proper connection of the replacement capacitors. See Illustration 4-13.
4. Remove the bleeder resistor and solder lugs.
5. Loosen the bolts on the capacitor mounting brackets (Item 3).
6. Carefully slide the capacitor out of the capacitor bracket.

To install the capacitors:

1. Carefully slide the capacitor (Item 4) into the capacitor mounting bracket (Item 3), taking care not to scratch the surface of the capacitor.
2. Tighten the capacitor mounting bracket.

CAUTION

Position the positive and negative terminals identically on both capacitors.

3. Attach the solder lugs and bleeder resistor (Item 7) on the terminals farthest from the control transformer (Item 11). See Illustration 4-13.
4. Attach the blue (or blue/white) wires to the negative (-) terminal and the red (or red/white) wires to the positive (+) terminals.
5. Finger-tighten the terminal screws. (Red, blue, red/white and blue/white wires from the output shelf will need to be reattached before the final tightening of the terminal screws.)

4.12.3. Servicing of Low Voltage Control Transformer

To remove the control transformer:

1. Trace the wires from the transformer to their terminations. Note and mark the connections to ensure proper installation of the replacement transformer. Disconnect the wires at the termination points, unbundle, and remove the low voltage control transformer.
2. Loosen the four nuts (Item 9) holding the control transformer to the studs on the large mounting bracket (Item 12).

To install the control transformer:

1. Fasten the control transformer (Item 11) to the main mounting bracket (Item 12).
2. To reassemble the inside unit, insert the mounting bracket (Item 12) (with the capacitors and transformer attached) through the bottom of the unit.
3. Insert capscrews (Item 14) from the bottom with shoulder washers (Item 15) on both ends. Fasten the washers and screws with 1/4-20 nuts and lockwashers then tighten securely.
4. Connect the wires at the termination points.

4.12.4. Servicing of Power Transformer

To remove the power transformer:

1. Note the wire locations and mark them as necessary. Particularly note the three Faraday shield wires from the transformer coils that are chassis-grounded behind the front panel. Except for the three Faraday shield leads, disconnect the wires at the termination points.
2. Remove the Main Circuit Board as described in Section 4.11.
3. Loosen, but do not remove, the six capscrews (Item 18) from the power transformer brackets. Remove the transformer shim (Item 20).

WARNING!

The Power transformer (Item 21) weighs over 40 pounds. Do not remove the mounting bolts (item 18) unless the transformer is supported. If servicing is taking place on a workbench, the transformer can be supported from underneath.

4. After ensuring that the transformer is securely supported, complete the removal of the six capscrews (Item 18). The detached transformer can be removed from the bottom of the main unit.
5. Once the transformer is removed from the unit, the upper and lower power transformer brackets can be removed by unbolting the capscrews.

To install the power transformer:

1. Attach the power transformer brackets to the transformer with the 3/4" capscrews. Be sure to place shoulder washers (6 each, Item 15) at top and bottom. Attach washer (Item 16) and nuts (Item 17) and tighten securely.
2. Insert the transformer from the bottom of the unit. Hold the transformer in the approximate position while starting the bolts (3 each, Item 18) into the transformer mounting brackets.
3. Reattach the mounting bracket (Item 12) that holds the capacitors and low voltage control transformer. Be sure to use shoulder washers at both the top and bottom.
4. Insert the stripped ends of the Faraday shield wires in between the chassis front panel and the aluminum shim (Item 20). Tighten all six bolts (Item 18) securely.
5. Fasten the capscrews with 1/4-20 nuts and tighten securely.
6. Connect the wires at the termination points.
7. Replace the output shelf as instructed in Section 4.6.

4.13. SERVICING OUTPUT WELL COMPONENTS

Model 8607 contains four different output wells that are located on the output shelf assembly (Illustration 7-1, Item 64). While the four different output wells appear similar, each is different and must be placed in a specific position. Illustration 4-15 shows the correct orientation of each of the four output wells and shows how the four different wells can be distinguished.

Output wells can be individually removed and installed without removing the output shelf.

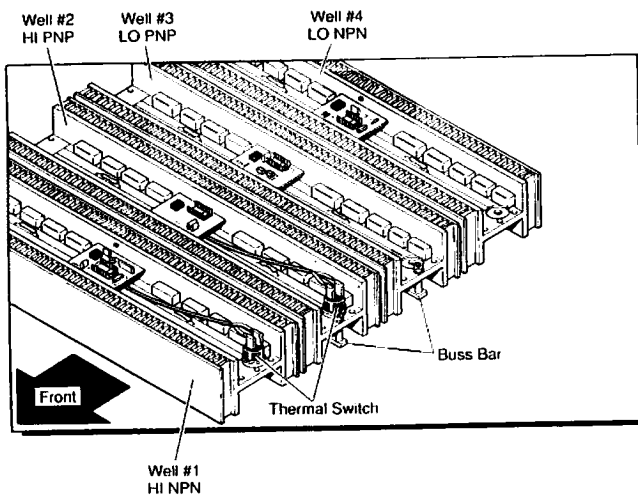

Illustration 4-14
Output Well Orientation

4.13.1. Removing and Installing Output Wells

WARNING!

Electric shock hazard! The Output Wells hold live current and are not earth-grounded. A shock hazard exists even with the AC mains disconnected. Before servicing the output wells, make sure that the capacitors are allowed to discharge. See safety procedures in Section 4.2.

Refer to Illustration 7-4 for the output well mounting procedure.

To remove any individual output well:

1. Disable the amplifier by performing shut down procedures in Section 4.2.2.
2. Remove the top panel by removing one screw from the back cover.
3. Disconnect the output interconnect board from the Main Circuit Board at J400.
4. Remove RTV Silicone Adhesive from the output interconnect board connectors to each predriver board.
5. Remove the four corner screws on the output well.
6. Remove two center mounting screws. One of the two center screws is recessed on wells 2 and 3.
7. Remove well by pulling it straight up. Do not force.

To install the output wells:

1. Insert the center conducting screws. Note that one of the center screws in each of the middle output wells is recessed below the surface. Torque to 20 in·lb (± 2 in·lb).
2. Insert four corner mounting screws. Torque to 8 in·lb (± 1 in·lb).
3. Reconnect the output interconnect board to the predriver boards and Main Circuit Board.
4. Glue connections to predriver boards with RTV Silicone Adhesive.

4.13.2. Output Transistors

To replace the transistor:

1. Disable the amplifier as explained in Section 4.2.2.
2. Remove the well with the defective component by performing Section 4.13.1.
3. Work from the bottom of the well.
4. For PNP wells (wells 2 and 3) only: each output transistor is connected to a central bus bar via a collector resistor. See Illustration 4-15. Unsolder the collector resistor of the faulty transistor from the bus bar.
5. Remove the transistor mounting screws. On PNP wells: the resistor solder lug on one screw serves as the star lockwasher.
6. Turn the output well over to work.
7. Unsolder the leads of the faulty transistor from the center portion of the gold-colored base PC board and from the emitter resistor lead.
8. Loosen the leads; then remove the faulty transistor.
9. Replace the transistor with one having the same *part* and *grade* number.

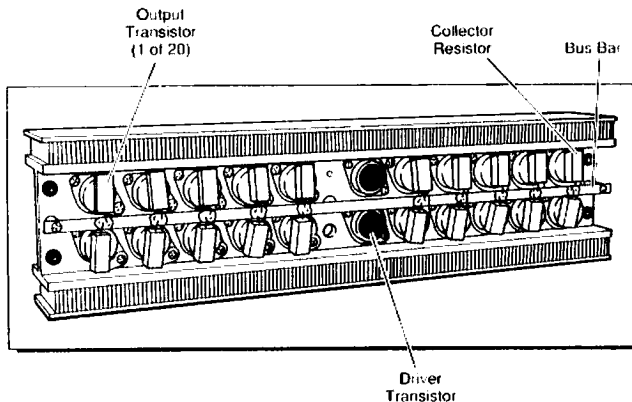

Illustration 4-15
PNP Output Wells Bottom View

CAUTION

The transistors in each output well are matched to each other. Stable amplifier operation cannot be assured unless the part number and grade number are matched on all transistors in each output well.

10. Apply heatsink compound (see Renewal Parts list) to the surface of the replacement transistor. Apply the compound lightly, but completely so that only a small amount will be squeezed out when the transistor screws are tightened.
11. Install the mounting screws and star lockwashers (solder lug for PNP wells). Tighten the mounting screws before resoldering the leads. Torque to 11 in-lb (± 2 in-lb).

CAUTION

Tightening the transistor mounting screws after the leads are soldered will break the internal transistor connections. Solder the transistor leads after the screws are tight.

12. Clinch the emitter resistor lead securely around the emitter lead of the transistor.

Note: To maintain the highest degree of dependability, the lead from the emitter resistor must be clinched around the lead of the transistor emitter.

13. Solder the leads in place.
14. For PNP wells only: resolder the collector resistor lead back onto the bus bar (using 175W-200W soldering iron) before replacement. For examples, see the other collector resistors on the same bus bar assembly.
15. See Testing and Adjustment Procedure, Section 5, for the necessary adjustment procedures.

4.13.3. Driver Transistors

See Illustration 4-67 for the location of the driver transistors.

1. Disable the amplifier as explained in Section 4.2.2.
2. Remove the well with the defective component.
3. Position the output well on its side to allow access to both the top and bottom.
4. Remove center screws from predriver board. On wells 1 and 4, the RTV Silicone Adhesive must be cut between the bias servo and heat sink. See Illustration 4-20. Lift the predriver board carefully, allowing the wiring to act as a hinge.
5. Remove the mounting bolts from the driver transistors.

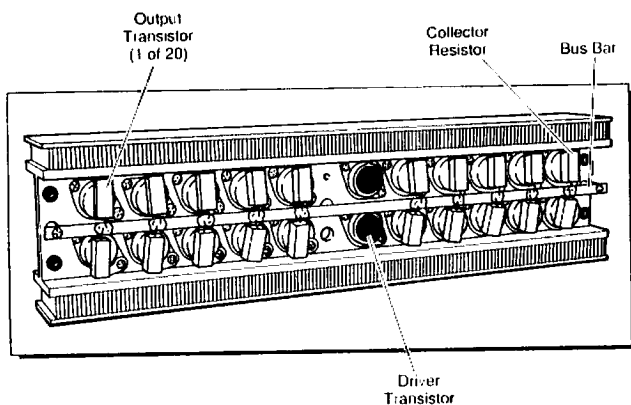

Illustration 4-16
Driver Transistor Position

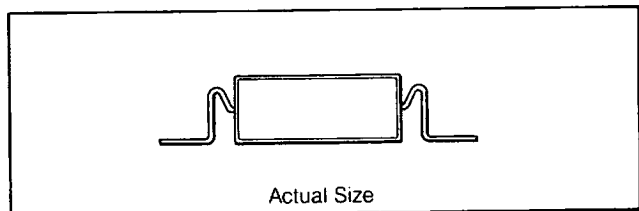

Illustration 4-17
Emitter Resistor Leads

CAUTION

To protect the solder connections from the pre-driver board, do not move the board more than necessary.

6. Unsolder the leads of the faulty driver transistor.
7. Apply heatsink compound to the mounting surface of the replacement transistor. Apply the compound completely and lightly so that only a small amount will be squeezed out when the transistor mounting screws are tightened.
8. Bolt the new driver transistor in place. The torque range is 11 in-lb (± 2 in-lb).
9. Solder the leads of the new transistor in place.
10. Screw predriver board onto well. If this is well 1 or 4, glue bias servo to heat sink using RTV Silicone Adhesive.
11. See Section 5, Testing and Adjustment Procedures for the necessary calibration procedures.

4.13.4. Emitter Resistors

Note: All 0.33 ohm, 5 watt emitter resistors used in the output wells, both top and bottom, are identical.

CAUTION

Emitter resistor characteristics are designed into the amplifier. Stable operation cannot be assured unless replacements are ordered from Techron

1. Disable the amplifier as outlined in Section 4.2.2.
2. Unsolder the resistor leads.
3. Loosen the emitter resistor lead from the emitter lead of the transistor.

CAUTION

The emitter resistor leads are extra long and are bent in an "S" shape to improve heat dissipation. Failure to make this bend may cause the solder to melt.

4. Install the replacement emitter resistor observing the "S" shape bends in the leads. See Illustration 4-17.
5. Clinch the emitter resistor lead tightly around the transistor emitter lead.

Note: To insure the highest level of dependability in operation, the emitter lead from the transistor must be clinched around the emitter resistor lead.

6. Solder the emitter resistor lead to the emitter lead of the transistor.
7. See Testing and Adjustment Procedure, Section 5, for the necessary adjustment procedures.

4.13.5. Electronic Heat Sensors, Wells 3 and 4 Only

See Illustration 4-18 for location.

To remove:

1. Disable the amplifier as outlined in Section 4.2.2.
2. Unsolder the leads and pull the sensor up and out of the recess.

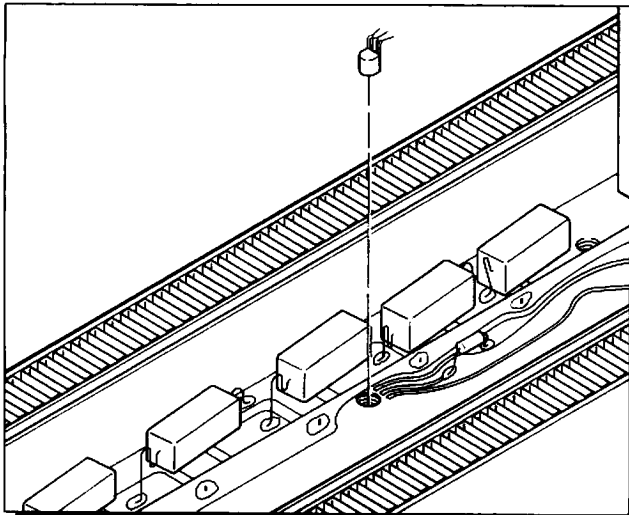

Illustration 4-18 Electronic Heat Sensors

To install:

1. Prepare the replacement sensor as follows:
 - a. Install 3/8" Teflon® insulating tube over each of the three sensor leads.
 - b. Bend the leads 90° at the bottom of the tubing.
 - c. Trim the excess lead to .150."
 - d. Fold the leads down against the flat side of the transistor body.
2. Insert the sensor in the heat sink.
3. Solder the leads.
4. Inspect the 1% resistor (R812 or R923), located about two inches towards the center from the sensor. Replace the resistor if the color dot on the replacement sensor does not match the required value.

Note: The resistor must be matched with the temperature sensor. See Table 4-1 for the proper matching. The color dot on the sensor indicates the matching type.

BLUE	236 OHMS, 1%
GREEN	227 OHMS, 1%
YELLOW	218 OHMS, 1%

Table 4-1 Resistor Color Matching

5. See Testing and Adjustment Procedures, Section 5, for the necessary adjustment procedures.

4.13.6. Thermal Switch, Wells 1 and 2 Only

See Illustration 4-19 for location of Thermal Switch.

To remove:

1. Disable the amplifier as outlined in Section 4.2.2.
2. Remove the well with the defective component.
3. Disconnect the leads from the thermal switch by pulling up on the plastic covered terminals.
4. Turn the thermal switch counterclockwise to remove it from the mounting position. The nut below is not captive.

To install:

1. Apply heat sink compound to the thermal switch.
2. Install the new thermal switch. Fasten the nut on the threaded shaft of the thermal switch.
3. Reconnect the black wires. The black wires are identical and interchangeable.

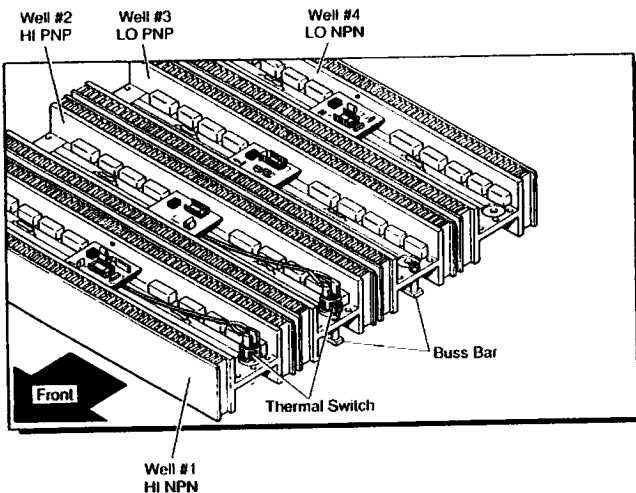

Illustration 4-19 Thermal Switch Location

4.13.7. Bias Servo Transistor, Wells 1 and 4 Only

Bias servo transistors can be replaced without removing the well from the amplifier. See Illustration 4-20 for location.

To remove:

1. Disable the amplifier by performing Section 4.2.2 procedures.
2. Disconnect the output interconnect board from the Main Circuit Board and the four predriver boards.
3. Remove the bias servo transistor from its position on the side of the heatsink.
4. Remove center screw from predriver board. Lift predriver board carefully, allowing the wiring to act as a "hinge."
5. Remove the old silicon glue from the heatsink.
6. Unsolder the bias servo transistor leads.

To install:

1. Solder the leads of the new transistor in place.
2. Screw predriver board back into well.
2. Position the new bias servo transistor with the flat side touching the heat sink.
3. Glue the new bias servo transistor in place with silicon glue. Use the other bias servo as a model of the proper gluing procedure. Ensure that the flat of the bias servo is contacting the heatsink.
4. Connect the output interconnect board and glue the connections to the predriver boards with RTV Silicone Adhesive.

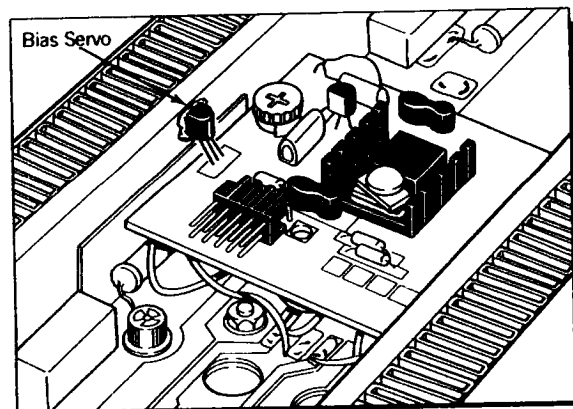

Illustration 4-20 Bias Servo Transistor

SECTION 5: TESTING AND ADJUSTMENT

5.1. INTRODUCTION TO TESTING AND ADJUSTMENT

The procedures outlined in this section must be performed following service to the Model 8607 amplifier. Procedures in this section are **NOT REQUIRED** following the replacement of fans.

On each two-page spread, this section includes an illustration of the Main Circuit Board with reference lines to the adjustment points used for each group of tests. See Illustration 5-1 as the first example.

<p>Tektronix 2215 Scope to observe waveforms Fluke 8060A DVM to measure voltage Wavetek Signal Generator 193 as signal source Non metallic screwdriver for tests, GC 8276or 8277 5 Milliohm Current Shunt Digital Signal Source .5 ohm, .5 millihenry load Shorting plug for Twinax Control Transformer (Crown part number M20643-9 XFMR, ISA 208/240V PREP #2) Techron Gradient Amplifier Exerciser (GAE) CMR Grounding Plug (see Illustration 5-5) Static Bridge Balance Probe (see Illustration 5-8)</p>
--

Table 5-1 Recommended Equipment

5.2. EQUIPMENT REQUIREMENTS

In addition to standard hand tools and electronic test equipment, **TECHRON** recommends the following specialized equipment to perform the tests in this Section. Using the equipment listed will help insure that Model 8607 can be tested and adjusted to factory specifications. Any compromises in equipment could result in a compromise in performance or calibration.

5.3. PREPARATION FOR TESTING

WARNING!

Fatal electric shock hazard! These tests and adjustments are performed with unit powered by 208 volt AC Mains and with protective panels removed. Test steps must be followed precisely and technician must exercise extreme caution to avoid accidental touching of improper terminals or components. Powerful and potentially lethal electric shocks can occur as a result of accidental contact with capacitors, terminals, heatsinks and other interior components.

Preparation steps:

1. Remove front, top and side panels.
2. Inspect wires, cables, connections, terminals and other visible components to check for breaks or broken parts. Generally check to see if unit appears to be in proper mechanical condition.

Note: All adjustments have been sealed at the factory. The seals must be broken in order to make new adjustments.

5.4. ADJUSTMENTS WITH A TECHRON GAE

The TECHRON Gradient Amplifier Exerciser (GAE) is a precision piece of test equipment designed to speed the testing of the 8607. Whenever possible, the GAE should be used to adjust or verify that the 8607 is operating at peak performance.

5.4.1. Initial GAE Settings

Set the GAE to the initial settings as listed in Table 5-2.

Switch	Settings
1. PWR/VAR/CLOCK	AC Power On
2. VAR/XTAL	XTAL (Down)
3. X5/X1	X1
4. Microsec Sample	20
5. DELAY/CONT/PULSE	CONT
6. FUNCTION	15
7. ZERO VAR/CAL	CAL (Down)
8. SHUNT/MON	MON (Down)
9. 10A/20A SHUNT	20A
10. GAIN VAR/CAL	CAL (Down)
11. ZERO OUT	Up
12. READY/STDBY	STDBY (Right)
13. LINEARITY RANGE	16 Bit
14. METER SEL	IO
15. TRIGGER SEL	TR1
16. SCOPE SEL	ERR (Error)
17. METER RANGE	10V
18. INPUT VOLTS	5.0
19. MON VOLTS	5.0

Table 5-2 GAE Initial Settings

5.5. DISABLE/ENABLE AMPLIFIER

The Disable/Enable procedures are used in several of the tests that follow. There are two ways to Disable/Enable the 8607:

- Set RDY/STBY switch on the GAE to the appropriate position.
- Set Main Board Jumper B4 right to enable, jumper out or left to disable.

5.6. AMPLIFIER GROUND

The internal electrical components of Model 8607 are not grounded to the chassis. Because of this floating ground feature, test equipment used in servicing Model 8607 should not be earth-grounded. There is a possibility of erroneous readings occurring from the use of grounded test equipment. Use an isolation transformer to float the test equipment from an earth ground.

5.7. INITIAL CONTROL SETTINGS

Perform the tests in this Section in sequence. Before starting these tests and adjustments, set the jumpers and switches on the 8607 main board as listed in Table 5-3. On all tests that follow, maintain the initial (or the prior) position for all control settings until instructed otherwise, i.e. unless a procedure specifically calls for an alternative setting for a particular control, you should assume that the setting is not to be changed from its current position.

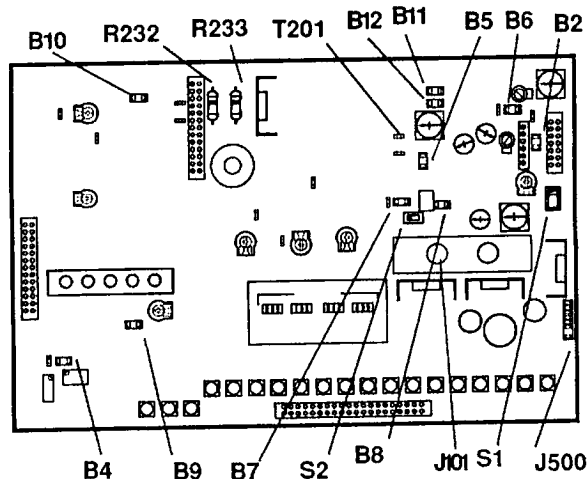

Illustration 5-1 Adjustment Points A

5.8. POWER SUPPLY PRETEST

WARNING!

Fatal electric shock hazard! Do not proceed until the 8607 has been disconnected from the AC mains. Dangerous voltage points are exposed in the next steps. Failure to disconnect AC could result in injury or death.

1. All Jumper and Switch settings are at initial positions as listed in Table 5-3.
2. Remove all rear panel connections. (As an alternative, disconnect all Main Board Ribbon Cable connections.)
3. Connect a signal generator to the left analog/Twinax input. Set for 300Hz Tone Burst.
4. Connect a temporary control transformer to J500. Use Crown Part Number M20643-9 (XFMR, ISA 208/240V PREP #2) to construct temporary transformer.
5. Set a two channel oscilloscope for 50 volt differential input. Connect scope to Main Board as follows:
 - a. Inverted channel at top of R232 (on left)
 - b. Non-inverted channel at top of R233 (on right)
6. Tap into the internal Vcc connections and connect a current limited power supply as follows:
 - a. Remove the right side fan panel.
 - b. Locate the bridge rectifier blocks nearest the fan. Disconnect the Vcc supplies from points A and B.
 - c. Connect voltage and current limited DC supplies to V1+, V1-, V2+ and V2- connection points. Set the supplies to limit at 60 volts and 0.3 amperes.
7. Look for any arcing or other disturbance which would indicate a major malfunction.
8. Connect Channel 1 scope probe to R233 and Channel 2 probe to T201. Connect the ground to shell of J101 (analog input).
9. Increase input signal and observe scope. There should be no oscillations. When output voltage is 80% of supply voltage, wave form should clip. See Illustrations 5-2 and 5-3 for appropriate waveforms before and after amplifier switches from low to high states.

JUMPER/SWITCH	FUNCTION	INITIAL SETTING
B2	Eddy Current	Install
B4	Remote/Local Enable	Remote (Right)
B5	Current/Voltage Mode	Constant Voltage(Dn)
B6	Compensation Select	1 ohm/ 1 mH (Right)
B7	Analog/Digital Input Select	Analog Input (Left)
B8	Clipper Bypass	Bypass (In)
B9	External Shim	Install
B10	Limiter Latch Enable	Disabled (Out)
B11*	Current Monitor Gain	In
B12*	Current Monitor Gain	In
*(Both B11 and B12 must be either both in or both out)		
S1	Master/Slave	Up (Master)
S2	Shim Input	Front Twinax Jack (Right)

Table 5-3 Initial Jumper and Switch Settings

5.9. PREPARATION FOR POWER ON TEST

1. Turn off the DC supply. Wait 2 minutes for the power supply capacitors to discharge.
2. Turn off the AC power to the DC supplies and the temporary transformer. Restore original wiring to Main board and to the Vcc supply.
3. Replace the fan cover.

5.10. AMPLIFIER POWER ON TEST

1. Disconnect external low voltage supply and reconnect amplifier voltage supply at J500.
2. Install 0.5 ohm, 0.5 millihenry load.
3. Connect input line voltage of 208 VAC.
4. Reconnect channel 1 scope to top of R233; channel 2 scope to T201.
5. Disable amplifier by removing Jumper B4.
6. Connect meter probes to Pin 1 of U119 and ground. Data latch reset should be 0 volts in STANDBY; and amplifier disabled.
7. Enable Amplifier. Voltage should be +5 volts DC in READY.
8. All 16 bit lights should be steady On, not flashing.

5.11. ANALOG FUNCTION TESTS

The following series of tests cover analog operations of the model 8607. Section 5.12 covers testing for digital operation.

5.11.1. Check +/- Vcc Voltage

1. Attach scope leads at left ground and top of R232.
2. Verify that Vcc voltage is $-40 \pm 4\text{VDC}$.
3. Move lead to top of R233.
4. Vcc voltage should be $+40 \pm 4\text{VDC}$.

CH1 20V A 1ms 40.2 V VERT

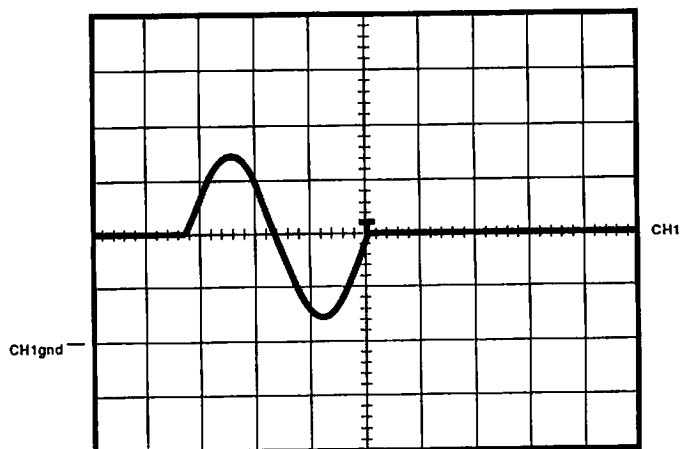

Illustration 5-2 Pre-test Wave Form A

CH1 20V A 1ms 40.2 V VERT

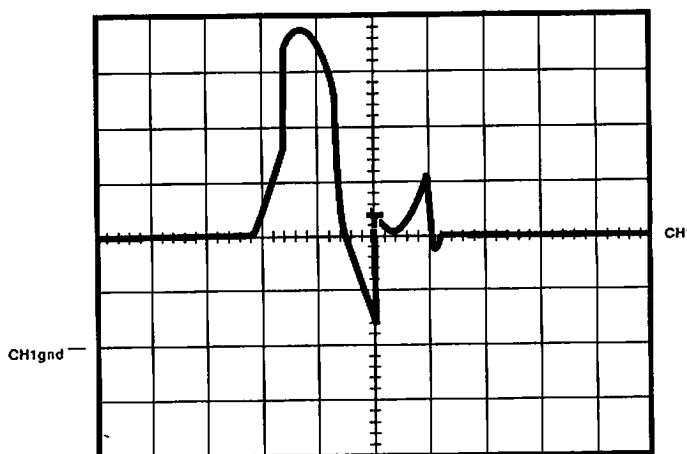

Illustration 5-3 Pre-test Wave Form B

5.11.2 Oscillation Tests

1. Switch S1 up to Master.
2. Connect scope probes to T201 and J101; ground to ground lug on J101, Twinax input.
3. Set input for 300Hz, pulse, 5 volts peak.
4. Increase the input signal until an error signal is seen on T201. See Illustration 5-4. Oscillations should not be observed on any part of the waveform, even beyond the clip point which should occur at about +/- 5 Volts peak to peak (see Illustration 5-4).
5. Lower input signal to about half of prior level.
6. Move scope probe from T201 to J101, ground lug on left Twinax input. (This is the same ground point from Step 2 above to check for ground-to-ground oscillations.)
7. Raise gain on scope to maximum sensitivity.
8. There should be no oscillations on any part of waveform.

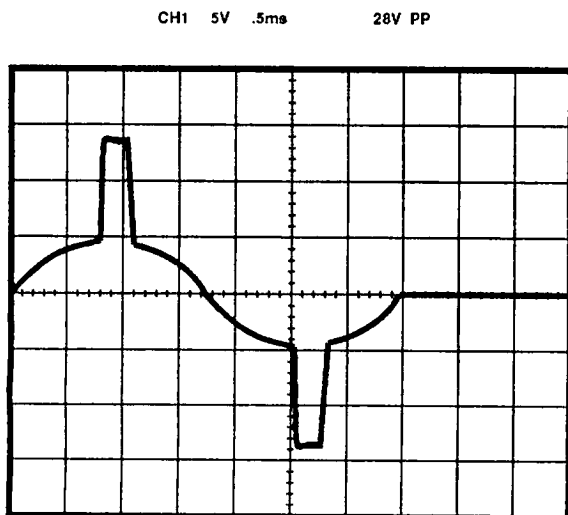

Illustration 5-4 Clip Point Waveform

5.11.3. Check +1 and -1 Inputs

This test can only be made with GAE.

1. Attach channel 1 probe of an oscilloscope to T103.
2. Attach channel 2 probe of an oscilloscope to green wire on left Twinax input.
3. Set S1 down to Slave.
5. Set FUNCTION switch to 15.
6. Push +1 button on the GAE.
7. Observe that channel 1 on the scope is in phase with channel 2.
8. Push -1 button on the GAE.
9. Observe that channel 1 on the scope is out of phase with channel 2.

5.11.4. Check Overload Reset

This test can only be made with GAE.

1. The J200 cable should already be connected.
2. Set S1 up to Master.
3. Move test probe from T103 to T201.
4. Raise signal until E500 lights, and you can observe clipping on waveform.
5. Lower signal below clip point.
6. Press OVERLOAD RESET button on GAE. Verify that N110 lights and that E500 goes out.

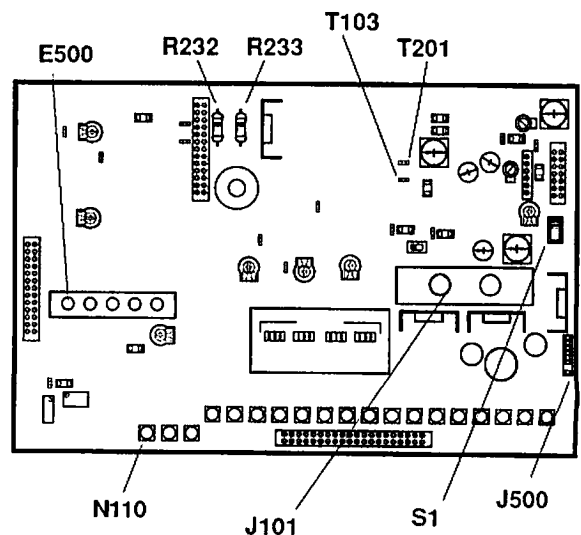

Illustration 5-5 Adjustment Points B

5.11.5. Current Monitor Zero Adjustment

1. Remove scope probe.
2. Disable amplifier.
3. Turn amplifier OFF at circuit breaker on back of amplifier.
4. Remove load.
5. Turn amplifier ON at circuit breaker on back of amplifier.
6. Remove Analog input signal from Twinax input.
7. Install a shorting plug into the J101 Twinax BNC input.
8. Connect meter between ground on Twinax and pin 6 of U130.
9. Set DC voltmeter to 200 millivolt scale and measure at pin 6 of U130.
10. Adjust P107 to $0.000 \pm .001$ volts.
11. Move ground to shell of right BNC center conductor input.
12. Adjust P108 to $0.0 \pm .02$ volts.
13. Remove shorting plug.
14. Turn amplifier OFF at circuit breaker on back of amplifier.
15. Connect load.
16. Turn amplifier ON at circuit breaker on back of amplifier.

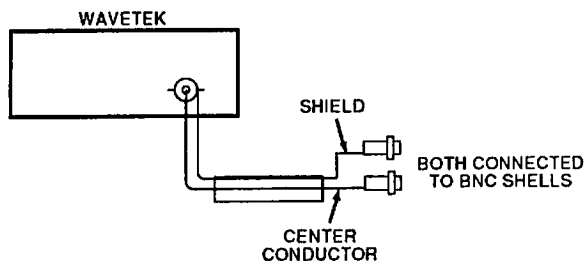

Illustration 5-6 Grounding Plug Schematic

5.11.6. CMR Adjustment

This adjustment is made at the factory and should not require adjustment thereafter.

1. Install special Grounding Plug into Twinax BNC input. See Illustration 5-5 for a schematic for constructing an appropriate Grounding Plug rig. Note that the ground connects to the shell of one BNC and the signal connects the shell of the other BNC.
2. Apply 1 kHz continuous sine wave between Twinax ground and BNC ground.
3. Measure on BNC output with AC voltmeter set at 200 millivolt scale.
4. Adjust N111 for minimum output voltage.
5. Remove grounding plug.

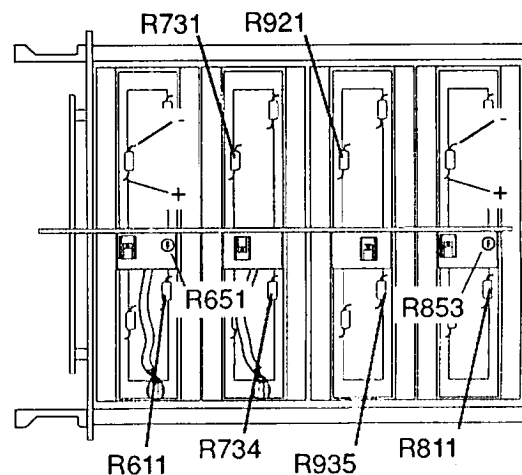

Illustration 5-7 Bias Voltage Test Points

5.11.7. Output Stage Bias Adjustment

This procedure tests each output well with voltmeter and adjusts for correct reading. Wells are to be tested in pairs (rear two, then front two); adjustments are for each pair in tandem. Illustration 5-7 shows the voltmeter test points.

Note: Allow output well heatsinks to cool to ambient temperature before performing this test.

1. Enable Amplifier by installing jumper B4.
2. Set S1 down to Slave.

For rear pair of output wells:

3. Connect voltmeter as shown in Illustration 5-7.
4. Adjust R853 on predriver board #4 for reading of $.400 \text{ VDC} \pm .01 \text{ VDC}$.

For front pair of output wells:

5. Connect voltmeter as shown in Illustration 5-7.
6. Adjust R651 on predriver board #1 for median reading of $.400 \text{ VDC}, \pm .01 \text{ volts}$.

Note: This adjustment must be balanced between the two output wells controlled by each adjustment point. Measure all four points and identify the median values. Adjust R651 and R853 to bring the median values to $.400 \pm .01 \text{ VDC}$.

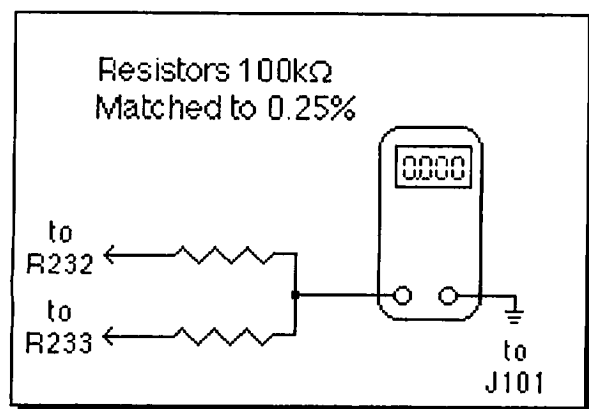

Illustration 5-8 Test Probe

7. Check voltage across R611, R721, R734, R811, R921, and R935. The voltages should be within $.01 \text{ volt}$. If not repeat steps 3 and 4 or 5 and 6.

5.11.8. Amplifier Offset Adjustment

1. Install a shorting plug in J101 (Twinax BNC).
2. Enable amplifier by installing jumper B4.
3. Set S1 down.
4. Connect a DC voltmeter to T103 and left ground.
5. Adjust R204 for $0.00 \text{ VDC} (+ .001 \text{ VDC})$ on the voltmeter.

5.11.9. Static Bridge Balance

1. Install a shorting plug in J101 (Twinax input).
2. Enable the amplifier.
3. Construct test probe as shown in Illustration 5-8.
4. Connect leads to the tops of R232 and R233.
5. Adjust R234 to $0.0 \text{ VDC} + .2 \text{ VDC}$.

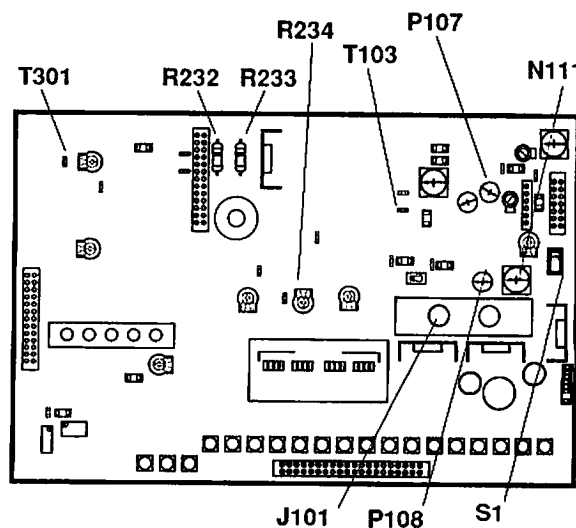

Illustration 5-9 Adjustment Points C

5.11.10. Adjust and Verify Simulator Zero

This test requires interior of unit to be at a stable operating temperature. If unit has recently been operating under load, allow ten minutes of cool-down time (with fans operating) to obtain valid readings.

1. Turn OFF amplifier at circuit breaker on back of amplifier.
2. Disconnect Load.
3. Turn ON amplifier at circuit breaker on back of amplifier.
4. Set S1 down.
5. Connect voltmeter lead from T300 to ground (shell of J101).
6. Measure the heatsink temperature of well #4 with a laboratory grade thermometer.
7. Adjust R305 and read T300 for the multiplier output voltage determined in step 4.
8. Measure the heatsink temperature of well #3 with a laboratory grade thermometer.
9. Determine simulator output voltage from Table 5-4.
10. Move voltmeter lead to T301.
11. Adjust R334 and read T301 for the simulator output voltage determined in step 9.

To verify simulator zero with the GAE, follow these steps:

10. Set the GAE METER RANGE switch to 10V.
11. Set METER SEL switch to T(+1). The meter reading should be 9.1 volts at 25° C.
12. Rotate the METER SEL switch to the other three positions. Each should have a magnitude of 9.1 volts, two positive, two negative.

Deg C	Deg F	Deg K	Simulator Output Voltage
10	50	283	SAT
11	52	284	SAT
12	54	285	SAT
13	55	286	SAT
14	57	287	SAT
15	59	288	SAT
16	61	289	SAT
17	63	290	12.96
18	64	291	12.84
19	66	292	12.72
20	68	293	12.60
21	70	294	12.48
22	72	295	12.36
23	73	296	12.24
24	75	297	12.12
25	77	298	12.00
26	79	299	11.88
27	81	300	11.74
28	82	301	11.64
29	84	302	11.52
30	86	303	11.40
31	88	304	11.28
32	90	305	11.16
33	91	306	11.04
34	94	307	10.92
35	95	308	10.80
36	97	309	10.68
37	99	310	10.56
38	100	311	10.44
39	102	312	10.32
40	104	313	10.20
41	106	314	10.08
42	108	315	9.96
43	109	316	9.84
44	111	317	9.72
45	113	318	9.60
46	115	319	9.48
47	117	320	9.36
48	118	321	9.24
49	120	322	9.12
50	122	323	9.00

Table 5-4 Temperature to Voltage Conversion

5.11.11. Adjust Analog Input Common Mode

1. Set S1 down to Slave.
2. Amplifier remains enabled.
3. Remove Shorting Plug.
4. Connect a signal generator to 8607 J101 Twinax input for a common mode signal input. See Illustration 5-10.
5. Set signal generator for a 1 kHz continuous triangle wave, 5 VAC peak.
6. Connect an oscilloscope to T103 and J101 Twinax ground.
7. Set S1 up to Master.
8. Adjust N100 and C123 for minimum amplifier output.

5.11.12. Adjust Dynamic Gain

1. Set dynamic gain (R236) full clockwise.

5.11.13. Set Analog Input Offset

1. Switch S1 down to Slave.
2. Connect 0.5 ohm, 0.5 millihenry load.
3. Install shorting plug into J101, BNC input.
4. Move jumper B5 up.
5. Set DC voltmeter to 200 mV scale and connect to T103 and ground of J101 Twinax input.
6. Switch S1 up to Master.
7. Adjust P102 for 0.000 VDC, ± 0.1 VDC.

Note: To set up meter for Digital Function Tests do the following:

8. Move meter probe to T100.
9. Press RELATIVE on meter for baseline reading.
10. Remove shorting plug.

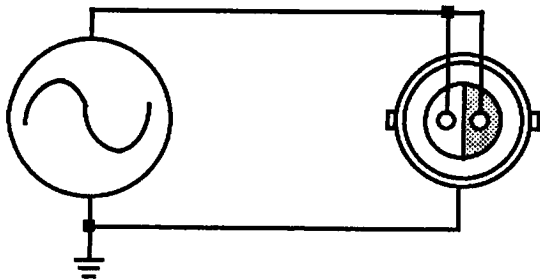

Illustration 5-10 Common Mode Input Connection

5.12. DIGITAL FUNCTION TESTS

The tests in Section 5.11 covered analog functions. This section 5.12 covers tests for digital functions.

Digital Function Tests require a GAE and cannot be made without it. If you have just completed some of the Analog Function Tests, refer to Section 5.14, Restoration.

Make following settings to prepare amplifier for digital tests:

1. Switch S1 down to Slave.
2. Switch S2 to middle position.
3. Move jumper B7 to right position.
4. Remove jumper B8.
5. Load remains on and Main Board Cables are connected.

5.12.1. DAC Calibration

1. Set GAE Monitor voltage to 5 volts.
2. Set sampling time to 200 microseconds.
3. Change GAE to function #1.
4. Adjust P100 to meter reading of -10.000 volts.
5. Change GAE to function #0. All LEDs should go out.
6. Adjust P101 to meter reading of 0.00 ± 0.1 volts. Compensate with relative reading.
7. Change GAE to function #1. Verify meter reading of -10.000 volts. Readjust P100 as necessary. Compensate for relative reading.

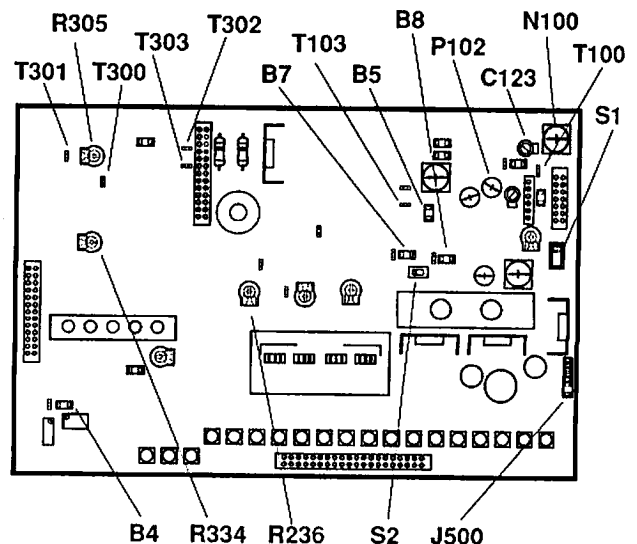

Illustration 5-11 Adjustment Points D

5.12.2. Gate Adjustment

1. Change GAE to function #0.
2. Set GAE microsample rate to 1000. (X5/X1 switch remains at X1.)
3. Move meter lead to T103 and note reading.
4. Set GAE microsample rate to 10.
5. Set GAE X5/X1 switch to X5.
6. Adjust C102 to same reading noted in step 3 above $\pm .001$. If the reading is not within this range, change component U127.

5.12.3. Adjust Clipper

1. Remove meter.
2. Set the GAE to Function #2. All lights should be flickering.
3. Set GAE microsecond sample to 200.
4. Set GAE X5/X1 to X1.
5. Set GAE Shunt/Mon to Shunt.
6. Connect an oscilloscope to T103.
7. Switch S1 up to Master.
8. Adjust P106 for 110 Volts peak at T103. See Illustrations 5-12 and 5-13 for waveforms before and after peak. Verify that unit goes into Overload.

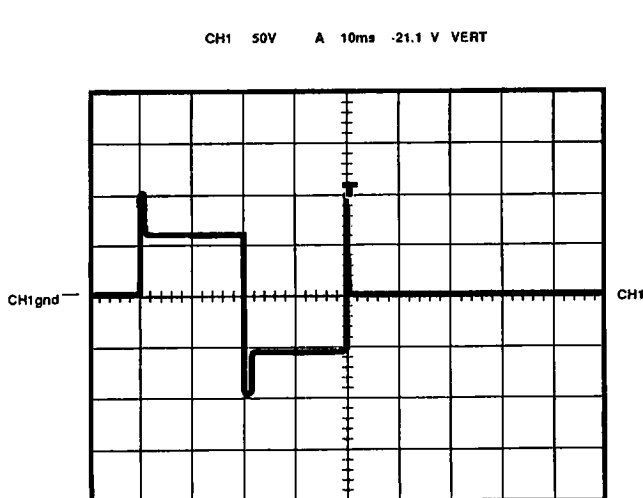

**Illustration 5-12 Clipper Adjust
Waveform A**

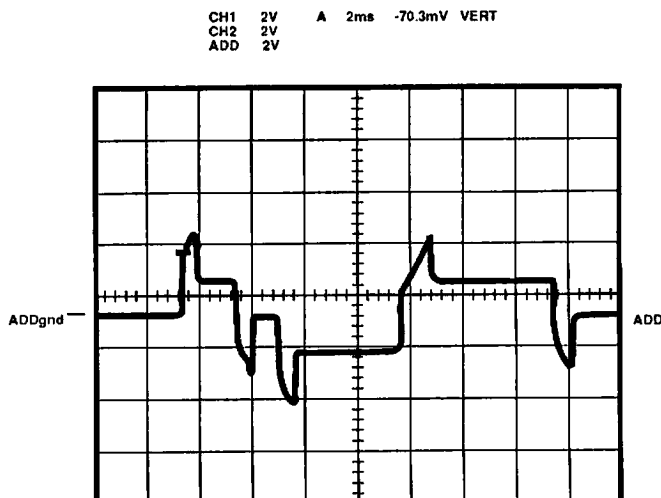

Illustration 5-13 Clipper Adjust Waveform B

5.12.4. Adjust Current Monitor Gain

1. Set GAE Scope/Sel switch to ERR.
2. Set GAE microsample to 200.
3. GAE function remains on pattern #2.
4. Adjust N102 until all GAE bit lights go off. (Note that amplifier LEDs stay flashing.)

5.12.5. Check Linearity >12.5 Amps

1. Change GAE to function #4.
2. GAE lights should stay off. Amplifier LEDs may change pattern but will stay lit.

5.12.6. Check Current Monitor Output

1. Switch GAE Var/Xtal up to Var.
2. By changing GAE Gain, verify that you can change error signal on scope. GAE bit lights stay out.
3. Switch GAE Shunt/Mon down to MON. Change gain and zero, and verify that all bit lights go off.
4. Switch GAE up to Shunt, and, by changing gain and zero, all lights go off.

5.12.7. Check Linearity <12.5 Amps

1. Change GAE to function #5.
2. Change GAE linearity from 12 to 14.
3. Adjust gain and zero to turn all bit lights off.
4. Switch GAE Shunt/Mon down to Mon. Bit lights may appear. Use Zero and Gain adjustments to verify that bit lights will go off.
5. Switch GAE Shunt/Mon up to Shunt.

5.12.8. Check Balanced Differential Input

1. Switch S1 down to Slave.
2. Set scope for differential input with one channel inverted. Adjust for 2 volts per division and 2 milliseconds per division.
3. Connect non-inverted channel at T201. Connect inverted channel to Ground.
4. Set GAE Trigger/Select to TR2.
5. Set GAE Linearity back to 12 bits.

6. Set GAE VAR/CAL switch to Calibrate.
7. Change GAE to function #10.
8. Set GAE microsample to 10 with delay.
9. For GAE functions 10,11, and 12, disregard bit lights and look for a waveform as shown in Illustrations 5-14. The peaks are unimportant; you are looking for an absence of oscillations on the flat portions of the wave.
10. See Illustration 5-14 for appropriate waveform.
11. Change GAE to function #11.
12. See Illustration 5-14 for appropriate waveform.
13. Change GAE to function #12.
14. See Illustration 5-14 for appropriate waveform.

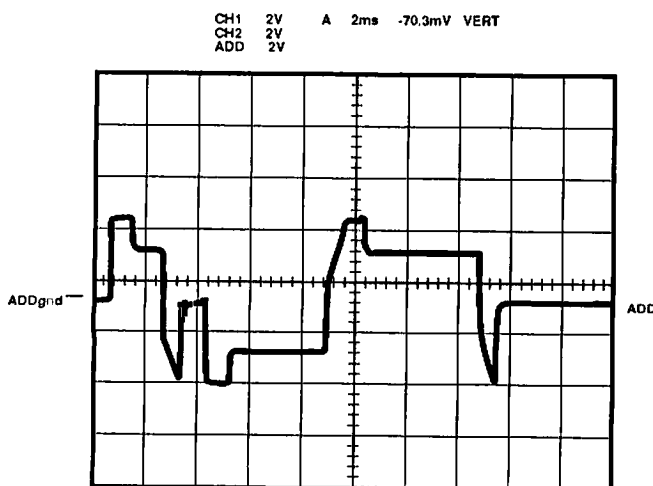

Illustration 5-14 Function #10-12
Waveforms

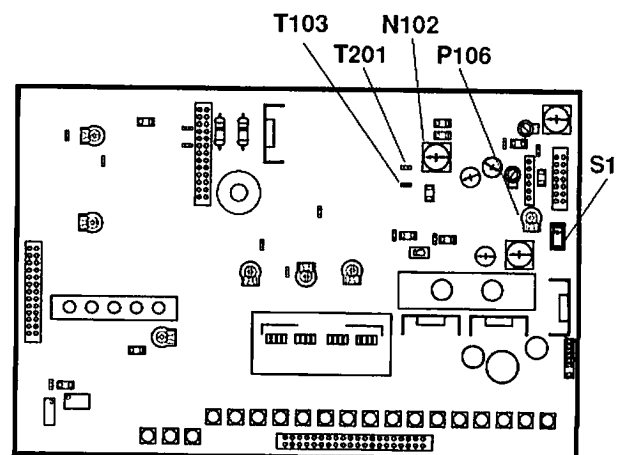

Illustration 5-15 Adjustment Points E

5.13. AMPLIFIER PROTECTION TESTS

This Section covers amplifier protection tests and final adjustments.

5.13.1. Check Fault Circuitry

1. Connect 560 ohm fault test probe between the low PNP heatsink and the collector of the PNP predriver. The 8607 should enter standby with both the fault LED and the overload LED on.
2. Power the unit down and back up. The amp should be enabled with the FAULT LED off.
3. Repeat Step 1 for high side PNP well.

5.13.2. Test Operation of Mechanical Thermal Switches

WARNING!

Heatsinks are live - Use Caution.

1. Disconnect TS1 (front thermal switch).
2. Observe LEDs. OVERLOAD, STANDBY, and OVERTEMP LEDs should light.
3. Reconnect TS1. LEDs should go out.
4. Test TS2 via steps 1,2,3, above (thermal switch - middle well).

5.13.3. Reliability

1. Disable the amplifier by removing B4.
2. Increase the voltage to 228 VAC.
3. Move B7 to the left position and B5 to the up position.
4. Connect a 500 millihenry inductor to the amplifier OUTPUT and sampled common terminals.
5. Apply a signal to J101 as follows:
+2.5 Volts DC for 45 seconds
-2.5 Volts DC for 45 seconds
6. Repeat Step 5.
7. Replace any output transistors that fail. Repeat this test until none fail.

5.13.4. Adjust High Mains Cut Off

1. Set line voltage 10% high (228.8VAC) and adjust R512 until E504 just lights.
2. Return line voltage back to normal (208VAC).

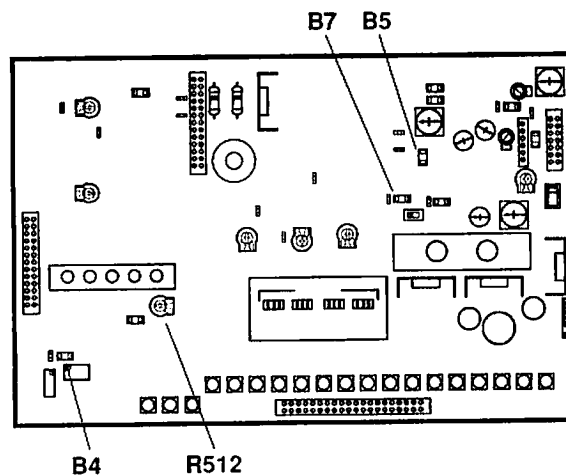

Illustration 5-16 Adjustment Points F

5.14. RESTORATION

5.14.1 Power Down

1. Disable amplifier by removing B4 jumper.
2. Switch OFF power to amplifier with circuit breaker CB1 jumper.
3. Disconnect test load from amplifier.
4. Seal all adjustments.
5. Set switches and jumpers as per Table 5-5 and Illustration 5-17.
6. Install all covers.

SWITCH/JUMPER	FUNCTION	MASTER SETTING	SLAVE SETTING
B2	Eddy Current	Install	Not Critical
B4	Enable	Right	Right
B5	Current/Voltage	Up	Not Critical
B6	Compensation	Left	Not Critical
B7	Input Select	Right	Not Critical
B8	Voltage Clipper	Install	Not Critical
B9	External Shim	Remove	Not Critical
B10	Limiter Latch Enable	Remove	Remove
B11	Current Monitor Gain	Install	Install
B12	Current Monitor Gain	Install	Install
S1	Master/Slave	Up	Down
S2	Analog In	Middle	Middle

Table 5-5 Final Jumper Settings

5.14.2 Power Up

1. Connect system load and data cables.
2. Switch ON power to amplifier and its paired master/slave amplifier.

LED	CONDITION
OVERLOAD	ON
FAULT	OFF
STANDBY	ON
READY	OFF
OVERTEMP	OFF

Table 5-6 LED Conditions

5.14.3. LED Status Digits

Verify amplifiers status LEDs per Table 5-6.

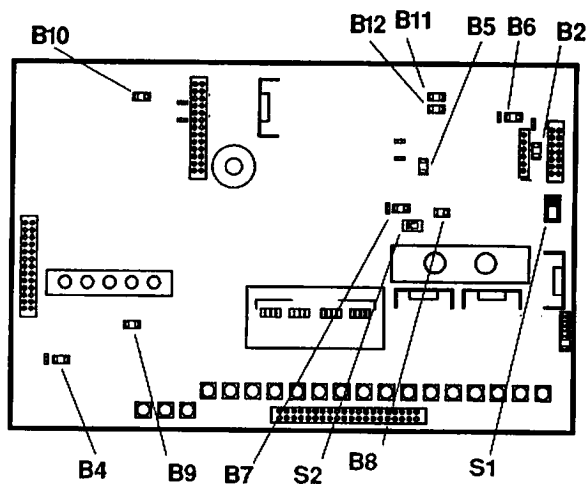

Illustration 5-17 Jumpers for Restoration

5.15. COMPONENT INTERACTION LIST

This section comprises a list of interaction between components. After replacement of any component, this table may be referenced to check other components that may need to be adjusted.

C100	NA	D100	P106
C101	C102	D101	P106
C102	ADJUST SAME	D102	P106
C103-C120	NA	D103-105	NA
C121	R101(SELECT)	D200-211	NA
C122	C123	D300-305	NA
C123	SAME	D400-413	NA
C124-C127	NA	D500-511	NA
C128	C102	D600-601	NA
C129	C102	D607	NA
C130-C132	NA	D650	R651
C133	SELECTED TO LOAD	D750	NA
C135	SELECTED TO LOAD	D850	NA
C136	SELECTED TO LOAD	D950	NA
C137	NA	E100-E119	NA
C138-139	NA	E500-505	NA
C140	C123	K1-2	NA
C141	SELECTED TO LOAD	L602	NA
C142	NA	L650	NA
C200-228	NA	L750	NA
C300-309	NA	L850	NA
C400-408	NA	L950	NA
C500-506	NA	N100	ADJUST SAME
C600	NA	N101	N102
C614	NA	N102	ADJUST SAME
C650-654	NA	N103-N110	NA
C700-701	NA	N300	R334
C750-752	NA	N302	NA
C800	NA	P100	ADJUST SAME
C850-853	NA	P101	ADJUST SAME
C900-901	NA	P102	ADJUST SAME
C950-953	NA	Q100-102	NA
New C		Q200-211	NA

Q300	R334	R200-203	NA
Q301	R334	R204	Adjust Same
Q302-306	NA	R205	R204
		R207-231	NA
Q200-502	NA	R232-233	R236
Q610-611	R651	R234	Adjust Same
Q612-621	NA	R235	R234
Q650	R651	R236	Adjust Same
Q651	NA	R237-240	R236
Q652	R651	R241	NA
Q700-721	NA	R242-253	NA
Q750	NA		
Q800-809	NA	R300-303	NA
Q810-811	R853	R304	R305
Q812-821	NA	R305	Adjust Same
Q850	R853	R306	R305
Q851	NA	R307-322	NA
Q852	R853	R323	R334
Q900-921	NA	R324-332	NA
Q950	NA	R334	Adjust Same
		R335-348	NA
R100	NA	R500-510	NA
R101	SELECT SAME	R511	R512
R102-R104	NA	R512	Adjust Same
R105	P102	R513	R512
R106	NA	R516-525	NA
R107	P106	R527-540	NA
R108	P106		
R109	C102	R600-624	NA
R110-R111	NA	R650	NA
R112	C102	R651	Adjust Same
		R652	R651
R113	P106	R654	R651
R114	P106		
R118	N102	R655	NA
R119	N102	R676	NA
R120-R126	NA		
		R701-744	NA
R128	C102	R750	NA
R129	C102	R761-763	N102
R130	NA		

R800-811	NA	U126	N100, C123
R812	Selected with U800	U127	C102
R813-827	NA	U128	C102, P102
R850-852	NA	U130	N102
R853	Adjust Same	U131-132	NA
R854-856	R853		
R857-858	NA	U200-201	NA
		U202	R204
R900-922	NA	U203	R234
R923	Selected with U900		
R924-945	NA	U300	R305, R334
R950-952	NA	U301-302	NA
T1	NA	U400	P102, R512
T2	R512	U401-402	NA
U100-U119	NA	U500-503	NA
U120	P101, P100		
U121	P101, P100	U800	R812
U122	C102		
U124	R101 (SELECT)	U900	R923

SECTION 6: EDDY CURRENT BOARD

6.1. INTRODUCTION

Use this section to test and verify operation of the 8607 Eddy Current Board (Grafidy 2 Board). Testing can be done with or without using a TECHRON Gradient Amplifier Exerciser (GAE). Adhere to the same testing preparations, warnings, and requirements given in Section 5, in addition to those given in this section. Final adjustments to the Eddy Current (Grafidy 2) Board are found in the GE Signa System manual.

Note: Certain models of the 8607 carry Eddy Current Boards that are not populated at J1, J2, and R5. Bypass any test procedures in this section where components are not available for adjustment.

6.2. SETUP FOR TESTING

1. Turn 8607 OFF at the rear panel circuit breakers.
2. Expose the Eddy Current Board and turn all controls (R17-R24) fully clockwise.
3. Remove all jumpers from the Eddy Current Board.
4. Set up the equipment as shown in Illustration 6-1 if a GAE is to be used in testing, otherwise, set up the equipment as shown in Illustration 6-3.

See Table 6-1 for initial equipment settings.

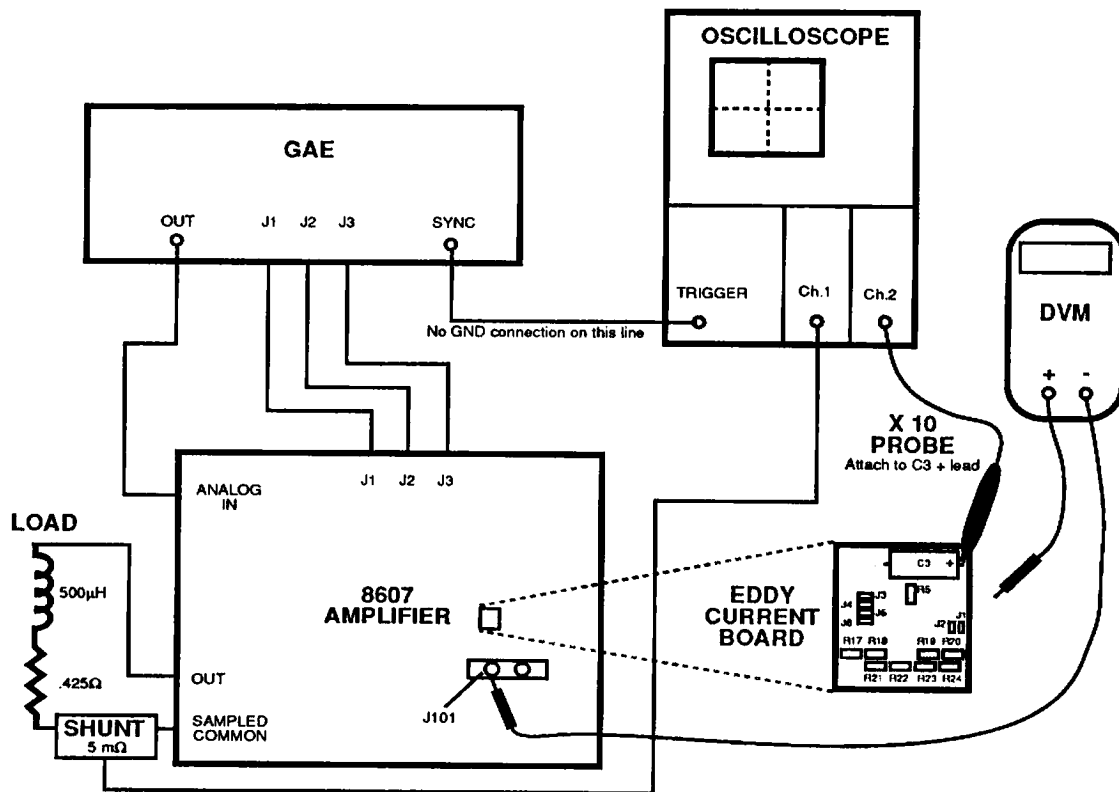

Illustration 6-1 Test Setup with GAE

6.3. INITIAL TESTING

1. Turn 8607 ON. Observe oscilloscope:
Ch2 should be a Square wave ± 2.5 div.
Ch1 a Straight line, at no divisions.
2. Set RDY/STBY switch on GAE to RDY. or,
if not using a GAE, set Main Board jumper
B4 right to enable.
Ch1 signal should be the same as Ch2.

GAE	
1. PWR/VAR/CLOCK	PWR
2. VAR/XTAL	XTAL (Down)
3. X5/X1	X1
4. Microsec Sample	200
5. DELAY/CONT/PULSE	DEL
6. FUNCTION	2
7. ZERO VAR/CAL	CAL (Up)
8. SHUNT/MON	MON (Down)
9. 10A/20A SHUNT	20A
10. GAIN VAR/CAL	CAL (Down)
11. ZERO OUT	CAL
12. READY/STDBY	STDBY (Right)
Oscilloscope	
Trigger Source	External
Trigger Mode	Normal/ DC/ +Slope
Horz. Timebase	5ms per division
Channel 1	DC/ 2 Volts per division
Channel 2	DC/ 0.1 Volts per div.
Vertical Mode	Dual/ Chop
Position	Center both Channels
Generator	
Frequency	300 Hz
Waveform	Square
Mode	Tone Burst
Rate	50 μ s
Output	2.5Volts

Table 6-1 Initial Equipment Settings

6.4. VERIFY VOLTAGE REFERENCE

See Illustration 6-2 for adjustment and jumper locations.

1. Install jumper at J1 on the Eddy Current Board. Observe oscilloscope.
Peaks on Ch2 should be 1 division higher than Ch1.
2. Set DVM for 20VDC. Connect the negative lead to J101 (BNC on main board) shell. With the positive lead, measure the voltage at the top of R17 on the eddy current board. Results should be 10.000 VDC $\pm .01$ VDC.
3. Move the positive lead of the DVM to the A (left) side of J3. Results should be 9.90 VDC $\pm .01$ VDC.
4. Move the positive lead of the DVM to the A (left) side of J4. Results should be 9.90 VDC $\pm .01$ VDC.
5. Move the positive lead of the DVM to the A (left) side of J5. Results should be 9.90 VDC $\pm .01$ VDC.
6. Move the positive lead of the DVM to the A (left) side of J6. Results should be 9.90 VDC $\pm .01$ VDC.

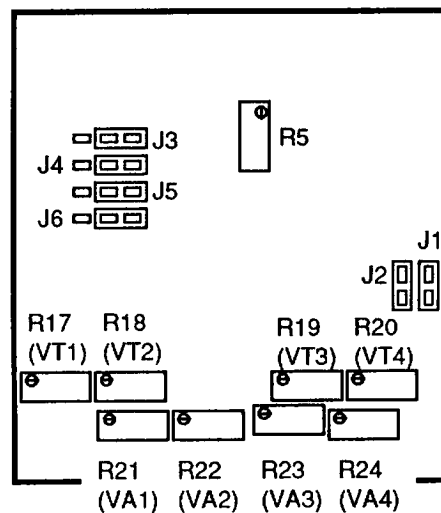

**Illustration 6-2
Eddy Current Board Adjustments**

6.5. VERIFY TIME CONSTANTS

1. Set scope for single channel display, Ch1. Ch 2 trace should disappear.
2. Set the vertical gain selector on scope Ch1 to .5V/Div. Waveform should be ± 1 division.
3. Install J6 in the right hand position. There should be no change in waveform.
4. Adjust R21 fully CCW. The waveform should be ± 1.2 to ± 1.4 divisions high.
5. Adjust R17 fully CCW. Leading edges of waveform should show small peaks approximately 0.4 vertical divisions high and 3 horizontal divisions long.
6. Remove J6. Waveform should be ± 1 vertical division.
7. Install J5 in the right hand position. There should be no change in waveform.
8. Adjust R22 fully CCW. The waveform should be ± 1.2 to ± 1.4 divisions high.
9. Adjust R18 fully CCW. Leading edges of waveform should show small peaks approximately 0.4 vertical divisions high and 1 horizontal division long.
10. Remove J5. Waveform should be ± 1 vertical division.
11. Install J4 in the right hand position. There should be no change in waveform.
12. Adjust R23 fully CCW. The waveform should be ± 1.2 to ± 1.4 divisions high.
13. Adjust R19 fully CCW. There should be 0.1 vertical division of tilt on horizontal portions of waveforms. Leading edges should be higher than trailing edges.

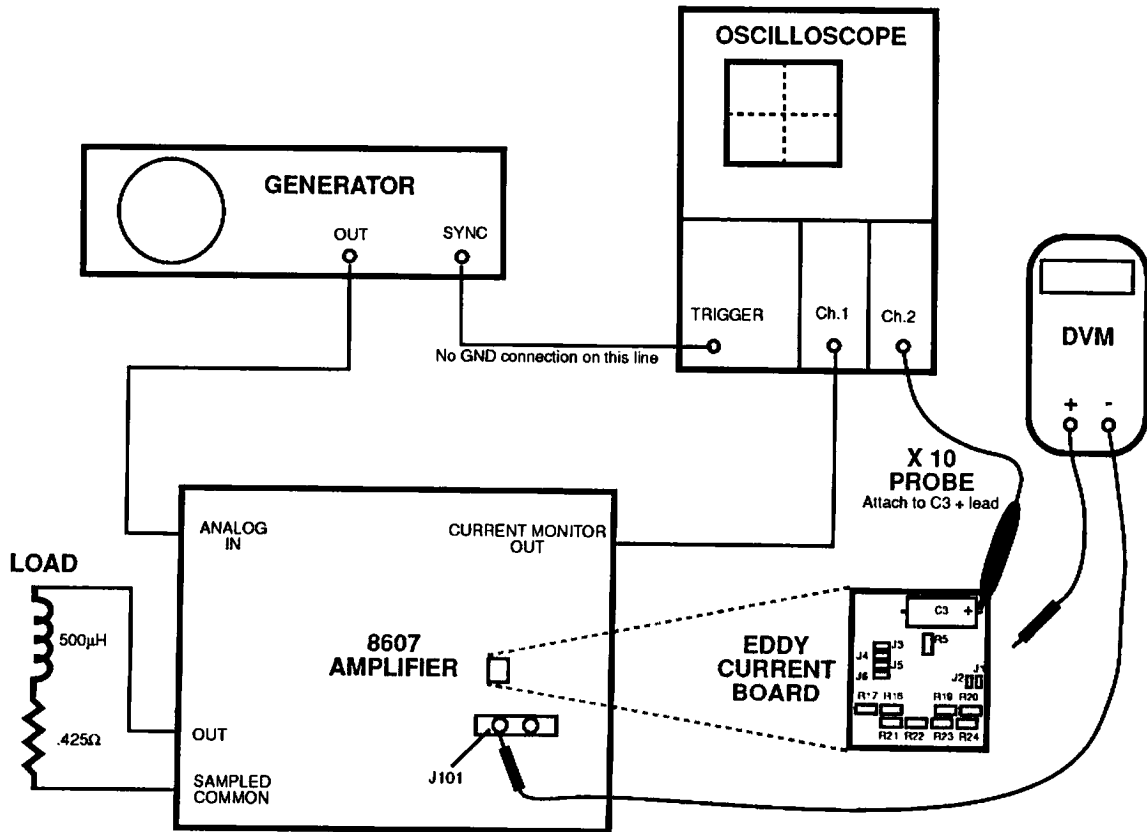

Illustration 6-3 Test Setup without GAE

14. Remove J4.
Waveform should be ± 1 vertical division.
15. Install J3 in the right hand position.
There should be no change in waveform.
16. Adjust R24 fully CCW.
The waveform should be ± 1.2 to ± 1.4 divisions high.
17. Turn R20 fully CCW.
There should be no change in waveform.
18. Remove J3.
Waveform should be ± 1 vertical division.
19. Set zero out switch on GAE down. If not using GAE, reduce Generator output to zero. Bit lights on 8607 should all go out.
20. Set DVM range to 2VDC. Clip + lead to T103 on Main Board.
Read amplifier offset voltage to be less than 5.0 mVDC.
21. Install J2.
New meter reading is DC offset voltage caused by R5. (Reading may be off scale.)
22. Adjust R5 for DC off set reading of less than ± 1 mVDC.
23. Remove J2. Disconnect DVM. Set GAE RDY/STBY switch to STBY. If not using GAE, set Main Board Jumper B4 left.
Observe 8607 LEDs: Green READY should turn off; Yellow STANDBY should turn on.

6.6. RETURN TO SERVICE

1. Install jumpers at J3, J4, J5, and J6 in their right hand position .
2. Install jumper at J1.
3. Adjust R17,R18, R19, R20, R21,R22, R23, and R24 until they are all in the approximate center positions (10 turns CW).

SECTION 7: EXPLODED VIEWS, PARTS LIST & SCHEMATICS

7.1. GENERAL PARTS INFORMATION

Section 7 includes illustrations, schematics, and parts lists for the Model 8607 Gradient Amplifier. This information should be used with the service, repair and adjustment procedures in Sections 5 and 6.

Mechanical and structural parts are illustrated and indexed on exploded view drawings. Electrical and electronic parts are listed and indexed in both the exploded view drawings and the schematic parts lists. The schematic designations correspond to those shown in schematic diagrams in Section 7.

Parts quantities used in each location are shown for the exploded view parts listing.

7.2. STANDARD AND SPECIAL PARTS

Many electrical and electronic parts used in Model 8607 are standard items stocked by and available from electronic supply houses. However, some electronic parts that appear to be standard are actually special. Order parts from TECHRON to be sure of a workable replacement. Structural items, covers and panels are available only from TECHRON.

7.3. ORDERING PARTS

TECHRON, a division of Crown International, supplies parts through the Crown International Parts Department. Replacement parts are obtained from the address below.

When ordering parts, be sure to give the model and serial number and include the part description and Crown Part Number (CPN) from the parts list. Price quotes are available upon request.

7.4. SHIPMENT

Shipment will be made by UPS or best method unless a preferred method is specified. Shipments are made F.O.B. Elkhart, Indiana only. Established accounts will have large orders shipped freight prepaid and billed.

7.5. TERMS

Normal terms are C.O.D., Master Card, or Visa, unless the order is prepaid. If prepaying, please add an amount for the freight charge. Average freight charge is \$1.50 per order up to one pound. New 30 day terms apply to established accounts. Parts prices are subject to change without notice. New parts returned for credit are subject to a 10% restocking charge.

You must receive authorization from the Crown Parts Department before returning parts for credit. Please state reason for returning.

Crown International Parts Department
1718 W. Mishawaka Road
Elkhart, Indiana 46517
(219) 294-8210
TWX 810 294-2160
FAX (219) 294-8329

7.6. MAIN CHASSIS PARTS LIST

ITEM #	PART #	QTY	DESCRIPTION
1	D 6289-9	1 PAIR	SLIDES, 18" X 21" WITH HARDWARE
2	F11197J4	1	PANEL, SIDE FAN
3	C 7308-7	2	SOLID STATE RELAY, 40 AMP
4	C 2228-2	5	8-32 X 5/8" MACHINE SCREW
5	D 6093A1	1	HANDLE, LEFT
6	C 7256-8	10	5/16-18 X 7/8" CAPSCREW
7	D 6108-1	2	HANDWELL
8	F11445J7	1	PANEL, FRONT
9	D 6999-3	4	#8 FIBER RETAINER WASHER
10	C 7667-6	4	8-32 U CLIP
11	C 6819-4	4	8-32 X .5" PAN HEAD SCREW
12	D7007-4	1	BOARD, MAIN CIRCUIT
13	D 6146-1	1	INSULATOR, MAIN CIRCUIT BOARD
14	M20462L8	1	SKIN, SUBFRONT PANEL
15	F10869K6	1	PANEL, SUBFRONT
16	B 5564-8	4.5"	GROMMET, CONTINUOUS
17	C 4014-4	1	1/2" SNAP BUSHING
18	C 7256-8	10	5/16-18 X 7/8" CAPSCREW
19	C 6519-0	6	.312" SPLIT RING LOCKWASHER
20	C 7667-6	4	8-32 U CLIP
21	F11441J6	2	BRACKET, FRONT PANEL
22	D 6094A1	1	HANDLE, RIGHT
23	F10762J6	1	COVER, BOTTOM
24	C 5099-4	2	8-32 X .37" MACHINE SCREW
25	M20677J6	1	BRACKET, TOP RIGHT
26	C 6519-0	10	5/16" SPLIT RING LOCKWASHER
27	C 6524-0	4	5/16-18 NUT
28	C 1951-0	6	#8 INTERNAL STAR LOCKWASHER
29	C 5305-5	2	10-32 FLATHEAD MACHINE SCREW
30	F11196J6	1	PANEL, RIGHT SIDE
31	C 2049-2	5	10-32 X 1/2" MACHINE SCREW
32	C 2279-5	2	#10 INTERNAL TOOTH LOCKWASHER
33	M20339-4	1	BRACKET, BOTTOM SIDE
34	M43851-1	1	FAN TERMINATOR ASSEMBLY
35	C 5594-4	10	#6 INTERNAL STAR LOCKWASHER

7.6. MAIN CHASSIS PARTS LIST (CONTINUED)

ITEM #	PART #	QTY	DESCRIPTION
36	C 1954-4	1	6-32 X .25" ROUND HEAD MACHINE SCREW
37	C 7456-6	1	GROMMET 2.0 OD 1.5 ID
38	C 4305-6	6	35A BRIDGE
39	C 4252-0	6	8-32 X .87" ROUND HEAD MACHINE SCREW
40	C 7864-9	8	6-32 X .625" SOCKET CAP MACHINE SCREW
41	C7858-1	4	FAN, 4.7" BALL BEARING
42	C 2048-2	5	10-32 X .5" MACHINE SCREW
43	C 2279-5	2	#10 INTERNAL TOOTH LOCKWASHER
44	D 5767-5	4	FOAM, FAN FILTER
45	B 5542-4	4	SLIDE, ISA FAN
46	F1076J8	2	PANEL, FAN SIDE
47	F10494-7	4	SLIDE, FAN SIDE PANEL
48	D 6309-5	16	6-32 X 1/4" HEX HEAD SCREW
49	C 6596-8	4	COVER, FAN
50	M20676J8	1	LEFT MOUNTING BRACKET
51	M20619J8	1	PANEL, 8607 CONNECTOR
52	C 6552-1	1	CIRCUIT BREAKER, 1A, 2 POLE, 240 VAC
53	C 4758-6	4	6-32 X 1/4" MACHINE SCREW
54	C 5594-4	10	#6 STAR LOCKWASHER
55	C 5297-4	3	8-32 X .37" TRUSS HEAD SCREW
56	C 6860-8	1	#10 EXTERNAL STAR LOCKWASHER
57	F11234J5	1	COVER, OUTPUT
58	C 6549-7	1	FEMALE TWIST LOC208 VAC
59	C 7408-5	1	CIRCUIT BREAKER, 20A, 3 POLE, 250 VAC
60	M20779J0	1	PANEL, BACK
61	C 6916-8	8	#10-24 X .375" PAN HEAD SELF TAPPING SCREW
62	F10766J7	1	COVER, TOP
63	C 5099-4	2	8-32 X .37" MACHINE SCREW
64	M43955-0	1	OUTPUT SHELF ASSEMBLY
65	C 7074-5	1	MOUNTING KIT
66	D 6431-7	1	J1 CABLE
67	D 6427-5	1	J2 CABLE
68	H42739-5	1	CABLE, INTERLOCK
69	F10639J6	4	WIRE MESH, FAN FILTER
70	C 6078-7	2	6-32 X .375" ROUND HEAD SCREW

7.6. MAIN CHASSIS PARTS LIST (CONTINUED)

ITEM #	PART #	QTY	DESCRIPTION
71	C 7292-3	1	.625" HOLE PLUG
72	C 1811-6	50	4" CABLE TIES
73	REF.		POWER SUPPLY
74	C 1986-6	2	8-32 HEX NUT
75			N/A
76	C 3163-0	4	SOLDER LUG, #6 HOLE
77	C 5994-4	10	#6 STAR LOCKWASHER
78	C 2176-3	1	6-32 X 5" ROUND HEAD SCREW
79	C 1889-2	1	6-32 HEX NUT
80	D 3312-2	2	SOLDER LUG, #10 HOLE
81	C 7377-2	2	.68MF 250V RFI CAP

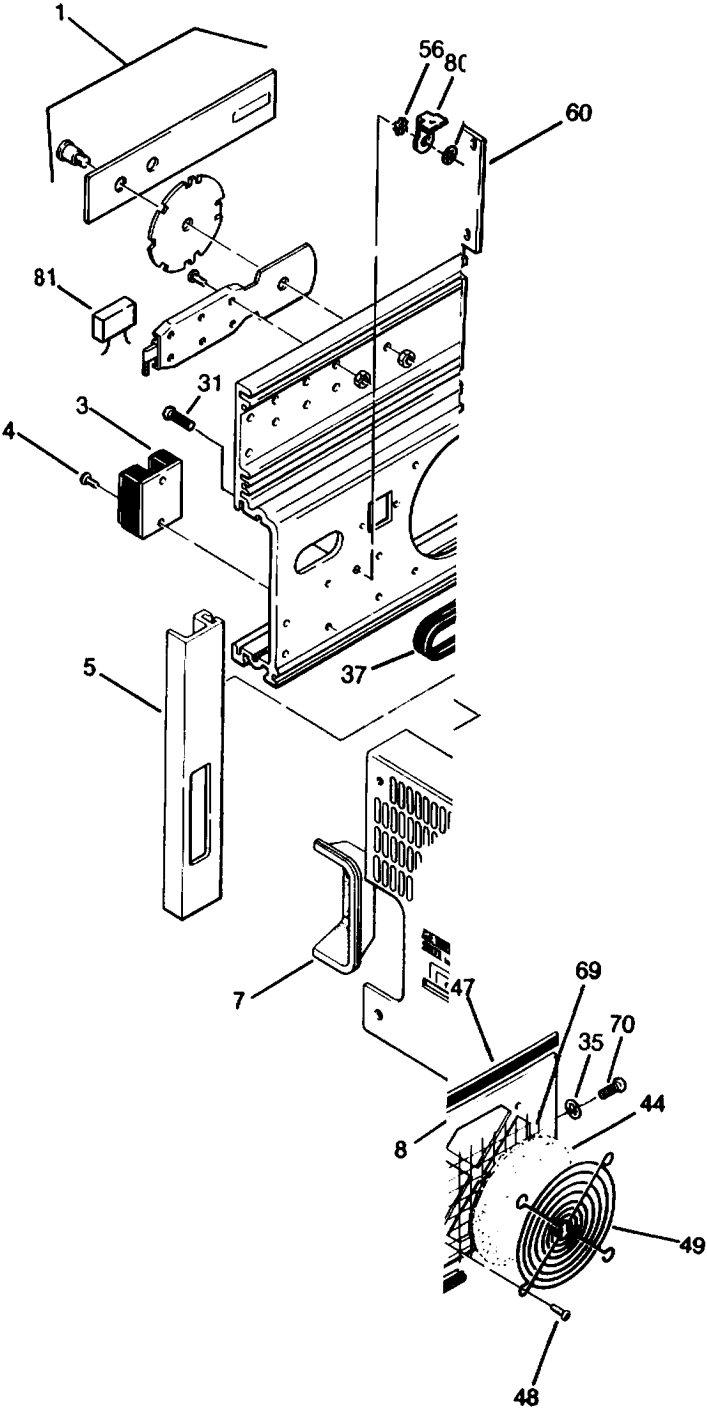

ITEM #	PART #	QTY	DESCRIPTION REF.
39	REF.	1	BOARD, ISA TERMINATOR 39 POST SOLDER
40	C 2155-7	2	8-32 X .37 TRUSS HEAD MACHINE SCREW ZINC
41	C 6860-8	4	#10 EXTERNAL STAR LOCKWASHER
42	F11306-2	1	BUS BAR, ISA BI-LEVEL SWITCH "C"
43	F11305-4	1	BUS BAR, ISA BI-LEVEL SWITCH "B"
44	F11304-7	1	BUS BAR, ISA BI-LEVEL SWITCH "D"
45	P10160-3	1	BOARD, ISA BI-LEVEL GATE CONNECTION SWITCH
46	C 7502-5	1	.47MF 250V STCK FILM CAPACITOR
47	C 6077-9	1	6-32 X .375 ROUNDHEAD MACHINE SCREW ZINC
48	C 5594-4	1	#6 INTERNAL STAR LOCKWASHER ZINC
49	C 7501-7	3	DIODE, IRT70HFL10S10 70A 100V
50	B 4782-7	11.2	.250 SHRINK TUBE BLACK
51	C 1889-2	3	6 X 32 HEX NUT
52	C 5594-4	3	#6 INTERNAL STAR LOCKWASHER
53	C 3575-5	6	500 OD X 195 ID FIBER WASHER
54	C 5963-1	10	141 X 250 X 125 NYLON SPACER
55	C 2274-6	4	8-32 X 3/8" FLAT HEAD SCREW
56	F10526-6	2	+VCC CONNECTING BLOCK
57	M20576-1	1	BUS BAR, OUTPUT WELD
58	D 6823-5	1	INSULATOR, OUTPUT BUS BAR
59	M20577-9	1	BUS BAR, COMMON WELD
60	D 6824-3	1	INSULATOR, COMMON BUS BAR
61	M20579-5	1	BUS BAR, -VCC WELD
62	D 6822-7	1	INSULATOR, -VCC BUS BAR
63	M20578-7	1	BUS BAR, +VCC WELD
64	D 6851-6	1	INSULATOR, +VCC BUS BAR
65	C 6345-0	2	6-32 X 1 FLAT HEAD SCREW

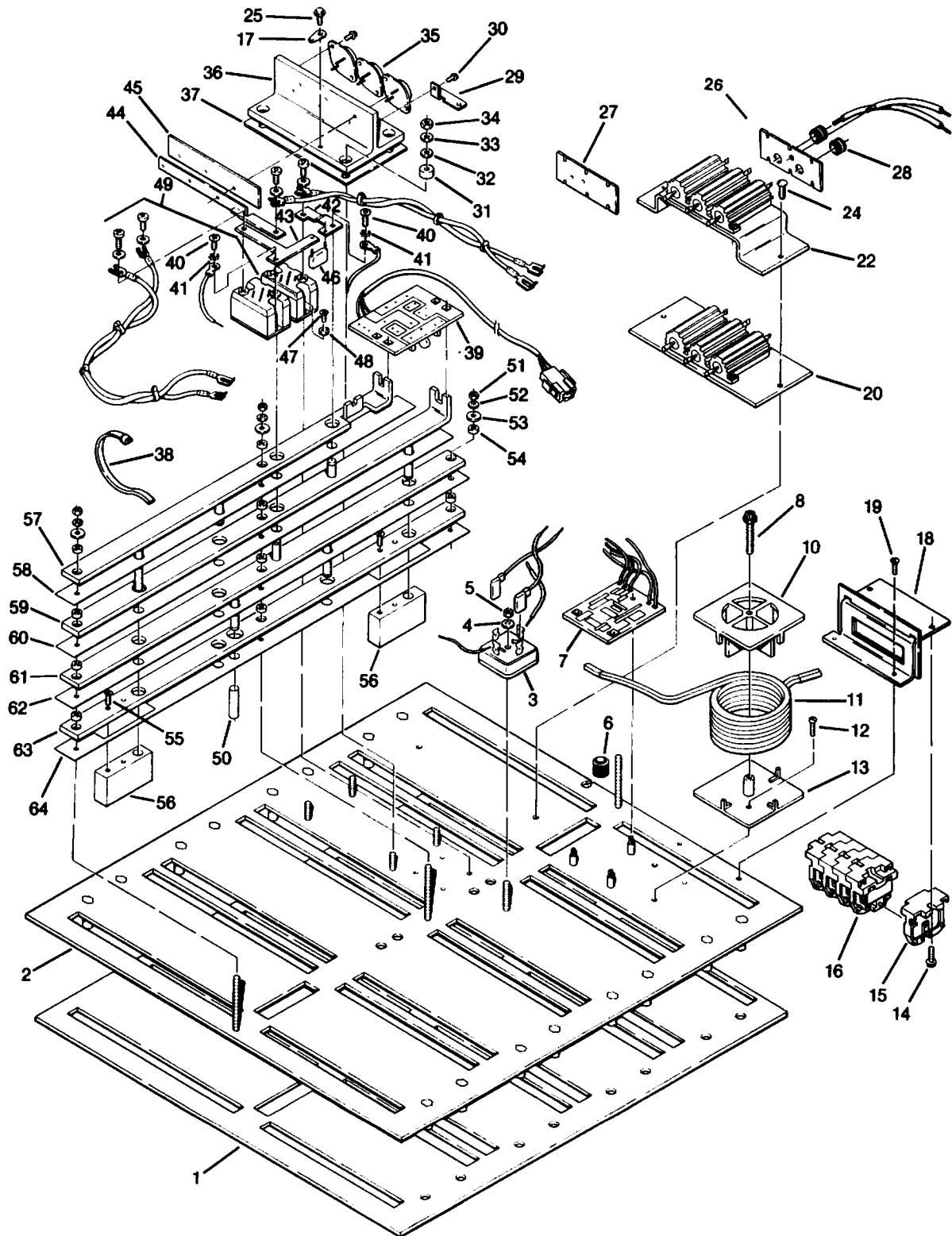

Illustration 7-2
Bus Bar and Heat Sink Exploded View

7.8. POWER SUPPLY PARTS LIST

ITEM #	PART #	QTY	DESCRIPTION
1	C 1951-0	6	#8 INTERNAL STAR LOCKWASHER
2	C 2271-2	6	8-32 X .25" MACHINE SCREW
3	C 7612-2	2	BRACKET, 3"
4	D 7632-9	2	20000MF 90V DC CAPACITOR, HES
5	C 7599-1	4	1/4-28 X .375" SOCKET HEAD MACHINE SCREW
6	C 7024-0	4	HDS-4 SAFETY WASHER, ZINC PLATE
7	C 7852-4	1	2.5K OHM 5W RESISTOR
8	D 3515-0	2	SOLDER LUG, .250" HOLE
9	C 1889-2	4	6 X 32 HEX NUT
10	C 2279-5	4	#10 LOCKWASHER
11	D 6519-4	1	TRANSFORMER, ISA CONTROL
12	M20645-4	1	BRACKET, BI-LEVEL TRANSFORMER/CAPACITOR
13	B 5564-8	1	CONTINUOUS GROMMET
14	C 6521-6	3	1/4-20 X 3.5" CAP SCREW
15	C 6502-6	6	NYLON SHOULDER WASHER
16	C 6518-2	3	1/4" SPLIT RING LOCKWASHER
17	C 6523-2	3	1/4-20 HEX NUT
18	C 7256-8	6	5/16-18 X 7/8" HEX CAP SCREW
19	C 6519-0	3	5/16" LOCKWASHER
20	F11019-1	2	SHIM, TRANSFORMER
21	D 6796-3	1	TRANSFORMER, MAIN POWER

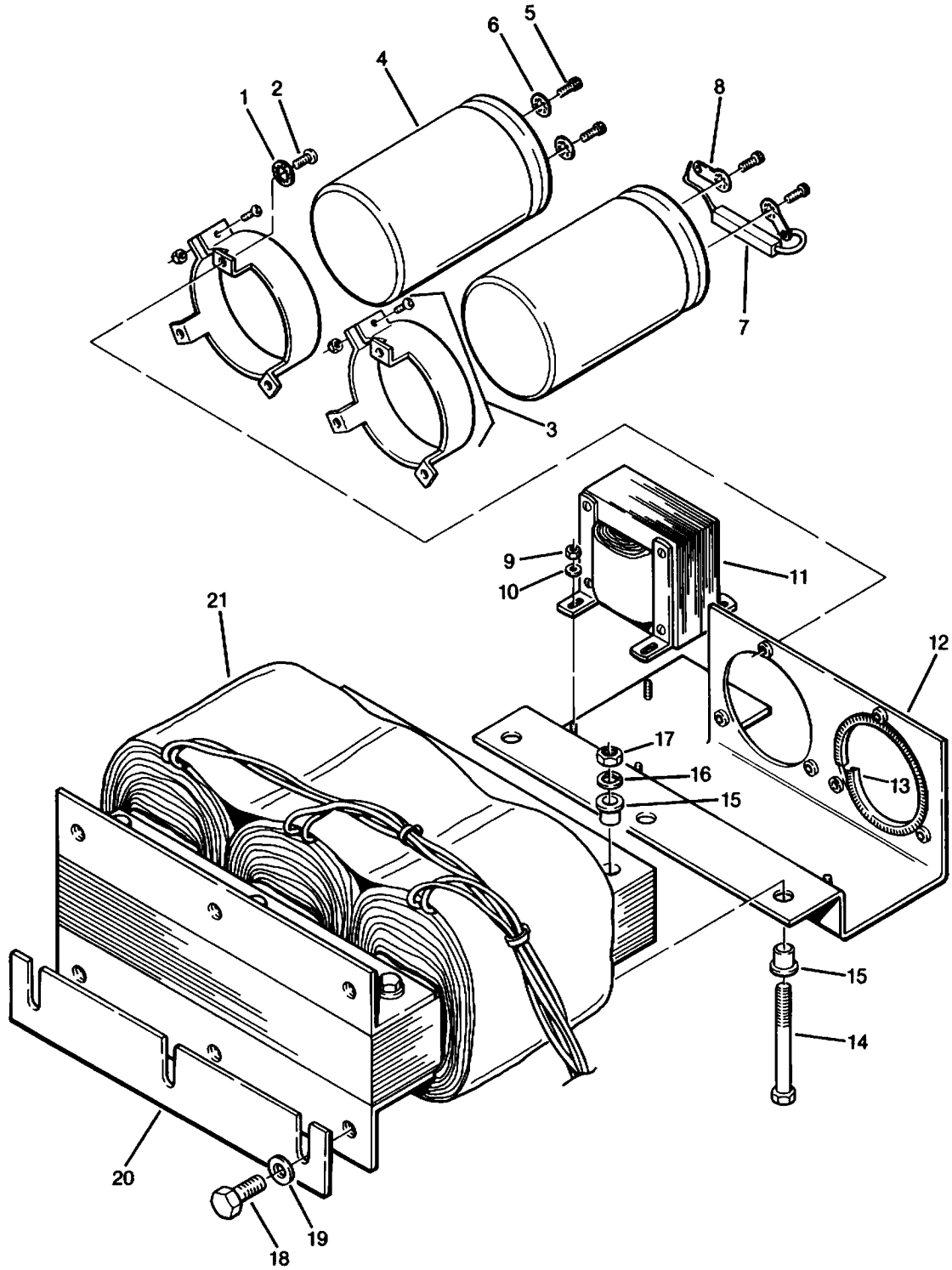

Illustration 7-3
Power Supply Exploded View

7.9. OUTPUT ASSEMBLY PARTS LIST

ITEM #	PART #	QTY	DESCRIPTION
1	C 6729-5	4	#8 SHOULDER WASHER, .375 ID X .171 ID
2	C 7655-1	2	.38 OD X .14 ID X .50 SPACER
3	C 6559-6		#6 SPLIT RING WASHER
4	C 5594-4	9	#6 INTERNAL STAR LOCKWASHER
5	C 6727-8	6	6-32 X .295" POZI TRI-LOBE SCREW
6	D 6727-8	6	6-32 X .295" POZI TRI-LOBE SCREW
7	C 2176-3	1	6-32 X .50" ROUND HEAD MACHINE SCREW
8	C 6897-0		#6 WASHER

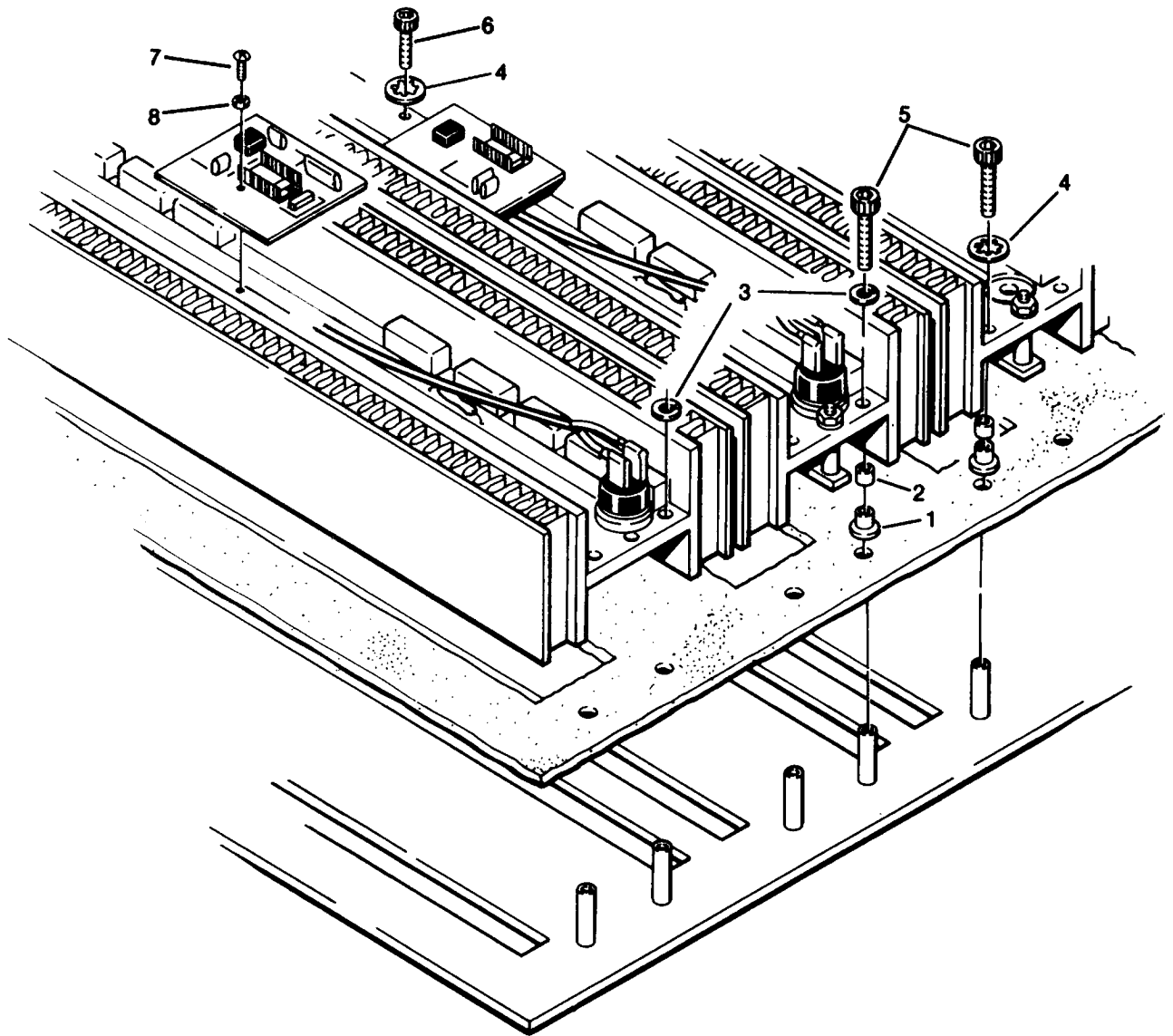

Illustration 7-4
Output Assembly Exploded View

7.10. SCHEMATIC PARTS LIST

LOCATION #	PART #	DESCRIPTION
B2	C 6419-3	SHUNT, .025" SQ. POST
B4	C 6419-3	SHUNT, .025" SQ. POST
B5	C 6419-3	SHUNT, .025" SQ. POST
B6	C 6419-3	SHUNT, .025" SQ. POST
B7	C 6419-3	SHUNT, .025" SQ. POST
B8	C 6419-3	SHUNT, .025" SQ. POST
B9	C 6419-3	SHUNT, .025" SQ. POST
B10	C 6420-1	.025 SQ. POST
B11	C 6420-1	.025 SQ. POST
B12	C 6420-1	.025 SQ. POST
B800	C 6513-3	BEAD
B801	C 6513-3	BEAD
B900	C 6513-3	BEAD
B901	C 6513-3	BEAD
C90	C 3977-3	.22MF 200V 5% FILM
C91	C 3978-1	.047MF 200V 5% FILM
C92	C 3978-1	.047MF 200V 5% FILM
C100	C 6130-6	.1MF 50V MONO
C101	C 2820-6	5.0PF MICA
C102	C 5058-0	30PF PC MOUNT TRIMMER
C103	C 6130-6	.1MF 50V MONO
C104	C 6130-6	.1MF 50V MONO
C108	C 6130-6	.1MF 50V MONO
C112	C 6130-6	.1MF 50V MONO
C116	C 6130-6	.1MF 50V MONO
C118	C 6130-6	.1MF 50V MONO
C119	C 6130-6	.1MF 50V MONO
C120	C 6130-6	.1MF 50V MONO
C121	C 4295-9	180PF DIPPED MICA
C122	C 3410-5	100PF DIPPED MICA
C123	C 5058-0	30PF PC MOUNT TRIMMER
C124	C 6130-6	.1MF 50V MONO
C125	C 6130-6	.1MF 50V MONO
C126	C 2821-4	10PF MICA
C127	C 3728-0	10MF 50V VERTICAL
C128	C 7386-3	1800PF 63V 1% STYRENE
C129	C 7386-3	1800PF 63V 1% STYRENE

7.10.SCHEMATIC PARTS LIST (CONTINUED)

LOCATION #	PART #	DESCRIPTION
C130	C 6130-6	.1MF 50V MONO
C131	C 6130-6	.1MF 50V MONO
C132	C 6130-6	.1MF 50V MONO
C135	D 4284-2	.01<F128M>M<F255D>F 100V 2% STYRENE
C136	D 4284-2	.01<F128M>M<F255D>F 100V 2% STYRENE
C137	C 4813-9	.068MF 100V CARBON
C138	C 4813-9	.068MF 100V CARBON
C140	C 2390-1	120PF DIPPED MICA
C141	C 3409-7	47PF DIPPED MICA
C142	C 5362-6	2.2MF 50V VERTICAL ELECTROLYTIC
C143	C 6130-6	.1MF 50V MONO
C144		N/A
C145	C 4813-9	.068MF 100V CARBON
C200	C 3410-5	100PF DIPPED MICA
C201	C 6130-6	.1MF 50V MONO
C202	C 6227-0	20PF MICA
C204	C 3409-7	47PF DIPPED MICA
C205	C 3409-7	47PF DIPPED MICA
C206		N/A
C207		N/A
C208	C 2342-1	27PF DIPPED MICA
C209		N/A
C210	C 3627-4	82PF MICA
C211	C 2342-1	27PF DIPPED MICA
C212	C 3627-4	82PF MICA
C213		N/A
C214	C 2820-6	5.0PF MICA
C215		N/A
C216	C 6130-6	.1MF 50V MONO
C217	C 6130-6	.1MF 50V MONO
C218	C 6130-6	.1MF 50V MONO
C220	C 3409-7	47PF DIPPED MICA
C221	C 2342-1	27PF DIPPED MICA
C222	C 3996-3	.0047MF 200V 5% FILM
C223	C 1751-4	.01MF 500V .3" LEAD DISC
C224	C 5243-8	.1MF 250V 5% POLYESTER
C225	D 4448-3	56PF 160V 2.5% STYRENE
C226	C 3409-7	47PF DIPPED MICA

7.10.SCHEMATIC PARTS LIST (CONTINUED)

LOCATION #	PART #	DESCRIPTION
C227		N/A
C228	C 2342-1	27PF DIPPED MICA
C229	C 2820-6	5.0PF MICA
C300	C 3729-8	100MF 16V VERTICAL
C301	C 6130-6	.1MF 50V MONO
C302	C 7283-2	8.9MF 35V 10% NP VERTICAL ELECTROLYTIC
C303	C 7281-6	.27MF 10% METAL POLYESTER
C304		N/A
C305	C 6130-6	.1MF 50V MONO
C306	C 7283-2	8.9MF 35V 10% NP VERTICAL ELECTROLYTIC
C307	C 7281-6	.27MF 10% METAL POLYESTER
C309	C 3729-8	100MF 16V VERTICAL
C310	C 5675-1	.01MF 50V 5% MONO CAP
C401	C 3728-0	10MF 50V VERTICAL
C402	C 4477-3	470MF 35V VERTICAL
C403	C 3728-0	10MF 50V VERTICAL
C404	C 4477-3	470MF 35V VERTICAL
C405	C 3729-8	100MF 16V VERTICAL
C406	C 7004-2	3300MF 16V 20% RAD ELECTROLYTIC
C411	C 7377-2	.68MF 250V RFI CAP
C416	C 7377-2	.68MF 250V RFI CAP
C416	C 2821-4	10PF MICA (ON BILEVEL CONTROL BOARD)
C417	C 2938-6	0.1MF200V 10%FILM
C417	C 2821-4	10PF MICA (ON BILEVEL CONTROL BOARD)
C418	C 2938-6	0.1MF200V 10%FILM
C418	C 3411-3	200PF DIPPED MICA (ON BILEVEL CONTROL BOARD)
C419	C 2938-6	0.1MF200V 10%FILM
C419	C 3728-0	10MF 50V VERTICAL (ON BILEVEL CONTROL BOARD)
C420	C 2938-6	0.1MF200V 10%FILM
C420	C 3411-3	200PF DIPPED MICA (ON BILEVEL CONTROL BOARD)
C421	C 2938-6	0.1MF200V 10%FILM
C421	C 6683-4	4700PF 50V 10% POLY FILM (ON BILEVEL CONTROL BOARD)
C422	C 2938-6	0.1MF200V 10%FILM
C423	D 7632-9	20000MF 90V DC CAPACITOR, HES
C424	C 2938-6	0.1MF200V 10%FILM
C425	C 2938-6	0.1MF200V 10%FILM
C426	C 2938-6	0.1MF200V 10%FILM
C427	C 2938-6	0.1MF200V 10%FILM
C428	C 2938-6	0.1MF200V 10%FILM
C429	C 2938-6	0.1MF200V 10%FILM

7.10.SCHEMATIC PARTS LIST (CONTINUED)

LOCATION #	PART #	DESCRIPTION
C430	D 7632-9	20000MF 90V DC CAPACITOR, HES
C431	C 7502-5	0.47MF250V STK FILM CAP
C500	C 1751-4	.01MF 500V .3" LEAD DISC
C501	C 5362-6	2.2MF 50V VERTICAL ELECTROLYTIC
C502	C 3996-3	.0047MF 200V 5% FILM
C504	C 6069-9	3.3MF 50V LOW LEAK
C505	C 6130-6	.1MF 50V MONO
C506	C 6130-6	.1MF 50V MONO
C507	C 1751-4	.01MF 500V .3" LEAD DISC
C508	C 5825-2	470PF MICA
C600	C 4404-7	.047MF 250V 5% CARBON
C650	C 3063-2	.0082MF 100V 10% POLYESTER
C651	C 3411-3	200PF DIPPED MICA
C652	C 3480-8	.001MF 200V 10% FILM
C653	C 5825-2	470PF MICA
C654	C 3480-8	.001MF 200V 10% FILM
C655	C 3285-1	.0022MF 100V 10% POLYESTER
C700	C 4404-7	.047MF 250V 5% CARBON
C750	C 3996-3	.0047MF 200V 5% FILM
C751	C 3411-3	200PF DIPPED MICA
C752	C 5825-2	470PF MICA
C753	C 8552-9	.012MF 200V 10% FILM
C754	C 1751-4	.01MF 500V DISC
C754	C 1751-4	.01MF 500V DISC
C800	C 3977-3	.022MF 200V 5% FILM
C850	C 6804-6	.1MF 50V AXIAL CERAMIC
C852	C 3480-8	.001MF 200V 10% FILM
C853	C 5825-2	470PF MICA
C854	C 3411-3	200PF DIPPED MICA
C900	C 3977-3	.022MF 220V 5% FILM MYLAR
C950	C 3288-5	.015MF 100V 10% FILM
C952	C 1751-4	.01MF 500V DISC
C953	C 5825-2	470PF MICA
C954	C 3411-3	200PF DIPPED MICA
CB1	C 7408-5	CIRCUIT BREAKER, 20A, 3 POLE, 250 VAC
CB2	C 6552-1	CIRCUIT BREAKER, 1A, 2 POLE, 240 VAC

7.10.SCHEMATIC PARTS LIST (CONTINUED)

LOCATION #	PART #	DESCRIPTION
D100	C 3181-2	DIODE, 1N4148
D101	C 3181-2	DIODE, 1N4148
D102	C 5900-3	DIODE, 1N960B
D103	C 3181-2	DIODE, 1N4148
D104	C 3181-2	DIODE, 1N4148
D105	C 3181-2	DIODE, 1N4148
D200	C 3181-2	DIODE, 1N4148
D201	C 3181-2	DIODE, 1N4148
D202	C 3181-2	DIODE, 1N4148
D203	C 3181-2	DIODE, 1N4148
D204	C 3181-2	DIODE, 1N4148
D205	C 3181-2	DIODE, 1N4148
D206	C 3181-2	DIODE, 1N4148
D207	C 3181-2	DIODE, 1N4148
D208	C 3181-2	DIODE, 1N4148
D209	C 3181-2	DIODE, 1N4148
D210	C 3181-2	DIODE, 1N4148
D211	C 3181-2	DIODE, 1N4148
D300	C 3181-2	DIODE, 1N4148
D302	C 3181-2	DIODE, 1N4148
D303	C 3181-2	DIODE, 1N4148
D304	C 3181-2	DIODE, 1N4148
D305	C 3181-2	DIODE, 1N4148
D306	C 3181-2	DIODE, 1N4148
D400	C 2851-1	RECTIFIER, 1N4004 SILICON
D401	C 2851-1	RECTIFIER, 1N4004 SILICON
D402	C 2851-1	RECTIFIER, 1N4004 SILICON
D403	C 2851-1	RECTIFIER, 1N4004 SILICON
D404	C 2851-1	RECTIFIER, 1N4004 SILICON
D405	C 2851-1	RECTIFIER, 1N4004 SILICON
D406	C 2851-1	RECTIFIER, 1N4004 SILICON
D407	C 2851-1	RECTIFIER, 1N4004 SILICON
D408	C 2851-1	RECTIFIER, 1N4004 SILICON
D409	C 2851-1	RECTIFIER, 1N4004 SILICON
D410	C 2851-1	RECTIFIER, 1N4004 SILICON
D417	C 3549-0	DIODE, 1N961B 10V ZENER
D418	C 6578-6	DIODE, 1N4735 6.2V ZENER
D417-D424	C 4305-6	35A BRIDGE
D419-D426	C 4305-6	35A BRIDGE

7.10.SCHEMATIC PARTS LIST (CONTINUED)

LOCATION #	PART #	DESCRIPTION
D421-D428	C 4305-6	35A BRIDGE
D429-D436	C 4305-6	35A BRIDGE
D431-D438	C 4305-6	35A BRIDGE
D433-D440	C 4305-6	35A BRIDGE
D500	C 3181-2	DIODE, 1N4148
D501	C 3181-2	DIODE, 1N4148
D502	C 3181-2	DIODE, 1N4148
D503	C 3181-2	DIODE, 1N4148
D504	C 3181-2	DIODE, 1N4148
D505	C 3181-2	DIODE, 1N4148
D506	C 3181-2	DIODE, 1N4148
D507	C 3181-2	DIODE, 1N4148
D508	C 3181-2	DIODE, 1N4148
D509	C 3181-2	DIODE, 1N4148
D510	C 3181-2	DIODE, 1N4148
D511	C 3181-2	DIODE, 1N4148
D512	C 2851-1	RECTIFIER, 1N4004 SILICON
D600	C 3181-2	DIODE, 1N4148
D607	C 4305-6	35A BRIDGE
D601	C 3181-2	DIODE, 1N4148
D650	C 2851-1	RECTIFIER, 1N4004 SILICON
D750	C 2851-1	RECTIFIER, 1N4004 SILICON
D751	C 2851-1	RECTIFIER, 1N4004 SILICON
D800	C 3181-2	DIODE, 1N4148
D801	C 3181-2	DIODE, 1N4148
D850	C 2851-1	RECTIFIER, 1N4004 SILICON
D950	C 2851-1	RECTIFIER, 1N4004 SILICON
D951	C 2851-1	RECTIFIER, 1N4004 SILICON
E100	C 7019-0	10 SEG LED BAR DISPLAY
E101	C 7019-0	10 SEG LED BAR DISPLAY
E102	C 7135-4	RED T1 LED
E103	C 7135-4	RED T1 LED
E104	C 7135-4	RED T1 LED
E105	C 7135-4	RED T1 LED
E106	C 7135-4	RED T1 LED
E107	C 7135-4	RED T1 LED
E108	C 7135-4	RED T1 LED
E109	C 7135-4	RED T1 LED

7.10.SCHEMATIC PARTS LIST (CONTINUED)

LOCATION #	PART #	DESCRIPTION
E110	C 7135-4	RED T1 LED
E111	C 7135-4	RED T1 LED
E112	C 7135-4	RED T1 LED
E113	C 7135-4	RED T1 LED
E114	C 7135-4	RED T1 LED
E115	C 7135-4	RED T1 LED
E116	C 7135-4	RED T1 LED
E117	C 7135-4	RED T1 LED
E118	C 7135-4	RED T1 LED
E119	C 7135-4	RED T1 LED
E500	C 4431-0	YELLOW LED
E501	C 4431-0	YELLOW LED
E502	C 7863-1	GREEN T1.75 LED
E503	C 7135-4	RED T1 LED
E504	C 4431-0	YELLOW LED
E505	C 4431-0	YELLOW LED
J1	D 6431-7	J1 CABLE
J2	D 6427-5	J2 CABLE
J3	H42739-5	CABLE, INTERLOCK
J100	C 6884-8	40 PIN EJECT HEADER #102332-9
J101	C 6877-2	TWINAX CONNECTOR
J102	C 6011-8	BNC, PANEL MOUNT
J103	C 7623-9	6 PIN HEADER, SHROUDED
J200	C 6463-1	STRAIT, EJECT 26P HDR
J300	C 6461-5	STRAIT, EJECT 14P RIBBON CBL HEAD
J400	C 6463-1	STRAIT, EJECT 26P HDR
J500	C 6481-3	AMPMOD4 8 PIN HEADER
J600	C 6564-6	10 PIN DOUBLE ROW HEADER
J750	C 6564-6	10P DOUBLE ROW HEADER
J850	C 6564-6	10 PIN COUBLE ROW HEADER
J950	C 6564-6	10 PIN DOUBLE ROW HEADER
K1	C 7308-7	SOLID STATE RELAY, 40 AMP
K2	C 7308-7	SOLID STATE RELAY, 40 AMP

7.10.SCHEMATIC PARTS LIST (CONTINUED)

LOCATION #	PART #	DESCRIPTION
L90	D 6831-8	COIL, ISA BI-LEVEL OUTPUT
L650	C 3510-2	CHOKER, .5MH AXIAL
L750	C 3510-2	CHOKER, .5MH AXIAL 470 UH
L850	C 3510-2	CHOKER, .5MH AXIAL LEAD
L950	C 3510-2	CHOKER, .5MH AXIAL LEAD
N100	D 6613-0	8607 INPUT RESISTOR/TRIMMER
N101	D 6411-9	INPUT RESISTOR NETWORK 16 BIT GE
N102	D 6214-7	RESISTOR/TRIMMER NETWORK #3
N103	C 7016-6	330 OHM RESISTOR NETWORK
N104	C 7016-6	330 OHM RESISTOR NETWORK
N105	D 6412A5	RESISTOR NETWORK A - 8607
N106	D 6412A5	RESISTOR NETWORK A - 8607
N107	D 6412A5	RESISTOR NETWORK A - 8607
N108	D 6412A5	RESISTOR NETWORK A - 8607
N109	D 6412A5	RESISTOR NETWORK A - 8607
N110	D 6412A5	RESISTOR NETWORK A - 8607
N111	D 4669-4	INPUT RESISTOR/TRIMMER D-75 BAL
N300	D 4922-7	RESISTOR NETWORK #16
N301	D 4922-7	RESISTOR NETWORK #16
N302	D 6709-6	RESISTOR NETWORK #21
P100	C 7020-8	200 OHM MT POT
P101	C 7640-3	100K OHM 25-TURN TRIMPOT
P102	C 4843-6	100K OHM CERMET TRIMPOT
P106	C 6346-8	2K OHM HORIZONTAL TRIMPOT
P107	C 4843-6	100K OHM CERMET TRIMPOT
P108	C 3671-2	10K OHM HELIPOT TRIMPOT
Q100	C 5135-6	2N5770 NPN
Q101	C 5135-6	2N5770 NPN
Q200	C 3625-8	2N4125 PNP
Q201	C 3625-8	2N4125 PNP
Q202	C 6911-9	UPA75HA DUAL NPN XSISTR SIP PK
Q203	C 3578-9	MPSA93 PNP
Q204	C 3810-6	MPSA43/A42 NPN

7.10.SCHEMATIC PARTS LIST (CONTINUED)

LOCATION #	PART #	DESCRIPTION
Q205	C 6910-1	UPA76HA DUAL NPN XSISTR SIP PK
Q206	C 3625-8	2N4125 PNP
Q207	D 2923-7	SEL 2N4929 PNP
Q208	C 4061-5	D40P5 POWER NPN
Q209	D 2961-7	SEL 2N3859A NPN
Q210	C 3625-8	2N4125 PNP
Q211	C 3625-8	2N4125 PNP
Q300	C 6911-9	UPA75HA DUAL NPN XSISTR SIP PK
Q301	C 6910-1	UPA76HA DUAL NPN XSISTR SIP PK
Q302	D 2961-7	SEL 2N3859A NPN
Q303	C 3625-8	2N4125 PNP
Q304	C 3625-8	2N4125 PNP
Q305	D 2961-7	SEL 2N3859A NPN
Q306	C 3625-8	2N4125 PNP
Q400	C 7405-1	SWITCH, MTM55N10 FET
Q401	C 7405-1	SWITCH, MTM55N10 FET
Q402	C 7405-1	SWITCH, MTM55N10 FET
Q403	D 2961-7	SEL 2N3859A NPN
Q500	C 6049-8	J-310 JFET
Q501	C 3625-8	2N4125 PNP
Q502	D 2961-7	SEL 2N3859A NPN
Q600	C 7614-8	MOTOROLA DUAL DIE 200V NPN
Q601	C 7614-8	MOTOROLA DUAL DIE 200V NPN
Q602	C 7614-8	MOTOROLA DUAL DIE 200V NPN
Q603	C 7614-8	MOTOROLA DUAL DIE 200V NPN
Q604	C 7614-8	MOTOROLA DUAL DIE 200V NPN
Q605	C 7614-8	MOTOROLA DUAL DIE 200V NPN
Q606	C 7614-8	MOTOROLA DUAL DIE 200V NPN
Q607	C 7614-8	MOTOROLA DUAL DIE 200V NPN
Q608	C 7614-8	MOTOROLA DUAL DIE 200V NPN
Q609	C 7614-8	MOTOROLA DUAL DIE 200V NPN
Q610	C 5869-0	2SD55RA PWR NPN
Q611	C 5869-0	2SD55RA PWR NPN
Q612	C 7614-8	DUAL DIE 200V NPN
Q613	C 7614-8	DUAL DIE 200V NPN
Q614	C 7614-8	DUAL DIE 200V NPN

7.10.SCHEMATIC PARTS LIST (CONTINUED)

LOCATION #	PART #	DESCRIPTION
Q615	C 7614-8	DUAL DIE 200V NPN
Q616	C 7614-8	DUAL DIE 200V NPN
Q617	C 7614-8	DUAL DIE 200V NPN
Q618	C 7614-8	DUAL DIE 200V NPN
Q619	C 7614-8	DUAL DIE 200V NPN
Q620	C 7614-8	DUAL DIE 200V NPN
Q621	C 7614-8	DUAL DIE 200V NPN
Q650	C 6436-7	2SC2336BR TO-220 NPN
Q651	C 3625-8	2N4125 PNP
Q652	D 2961-7	SEL 2N3859A NPN
Q700	C 7614-8	DUAL DIE 200V NPN
Q701	C 7614-8	DUAL DIE 200V NPN
Q702	C 7614-8	DUAL DIE 200V NPN
Q703	C 7614-8	DUAL DIE 200V NPN
Q704	C 7614-8	DUAL DIE 200V NPN
Q705	C 7614-8	DUAL DIE 200V NPN
Q706	C 7614-8	DUAL DIE 200V NPN
Q707	C 7614-8	DUAL DIE 200V NPN
Q708	C 7614-8	DUAL DIE 200V NPN
Q709	C 7614-8	DUAL DIE 200V NPN
Q710	C 5869-0	2SD55RA PWR NPN
Q711	C 5869-0	2SD55RA PWR NPN
Q712	C 7614-8	DUAL DIE 200V NPN
Q713	C 7614-8	DUAL DIE 200V NPN
Q714	C 7614-8	DUAL DIE 200V NPN
Q715	C 7614-8	DUAL DIE 200V NPN
Q716	C 7614-8	DUAL DIE 200V NPN
Q717	C 7614-8	DUAL DIE 200V NPN
Q718	C 7614-8	DUAL DIE 200V NPN
Q719	C 7614-8	DUAL DIE 200V NPN
Q720	C 7614-8	DUAL DIE 200V NPN
Q721	C 7614-8	DUAL DIE 200V NPN
Q750	C 5453A1	2SA1006BR TO-220 PNP
Q800	C 7614-8	DIE 200V NPN
Q801	C 7614-8	DIE 200V NPN
Q802	C 7614-8	DIE 200V NPN
Q803	C 7614-8	DIE 200V NPN
Q804	C 7614-8	DIE 200V NPN

7.10.SCHEMATIC PARTS LIST (CONTINUED)

LOCATION #	PART #	DESCRIPTION
Q805	C 7614-8	DIE 200V NPN
Q806	C 7614-8	DIE 200V NPN
Q807	C 7614-8	DIE 200V NPN
Q808	C 7614-8	DIE 200V NPN
Q809	C 7614-8	DIE 200V NPN
Q810	C 5869-0	2SD555RA PWR NPN
Q811	C 5869-0	2SD555RA PWR NPN
Q812	C 7614-8	DIE 200V NPN
Q813	C 7614-8	DIE 200V NPN
Q814	C 7614-8	DIE 200V NPN
Q815	C 7614-8	DIE 200V NPN
Q816	C 7614-8	DIE 200V NPN
Q817	C 7614-8	DIE 200V NPN
Q818	C 7614-8	DIE 200V NPN
Q819	C 7614-8	DIE 200V NPN
Q820	C 7614-8	DIE 200V NPN
Q821	C 7614-8	DIE 200V NPN
Q850	C 6436-7	2SC2336BR TO-220 NPN
Q851	C 3625-8	2N4125 PNP
Q852	D 2961-7	SEL 2N3859A, NPN
Q900	C 7614-8	DUAL DIE 200V NPN
Q901	C 7614-8	DUAL DIE 200V NPN
Q902	C 7614-8	DUAL DIE 200V NPN
Q903	C 7614-8	DUAL DIE 200V NPN
Q904	C 7614-8	DUAL DIE 200V NPN
Q905	C 7614-8	DUAL DIE 200V NPN
Q906	C 7614-8	DUAL DIE 200V NPN
Q907	C 7614-8	DUAL DIE 200V NPN
Q908	C 7614-8	DUAL DIE 200V NPN
Q909	C 7614-8	DUAL DIE 200V NPN
Q910	C 5869-0	2SD555RA POWER NPN
Q911	C 5869-0	2SD555RA POWER NPN
Q912	C 7614-8	DUAL DIE 200V NPN
Q913	C 7614-8	DUAL DIE 200V NPN
Q914	C 7614-8	DUAL DIE 200V NPN
Q915	C 7614-8	DUAL DIE 200V NPN
Q916	C 7614-8	DUAL DIE 200V NPN
Q917	C 7614-8	DUAL DIE 200V NPN
Q918	C 7614-8	DUAL DIE 200V NPN
Q919	C 7614-8	DUAL DIE 200V NPN

7.10.SCHEMATIC PARTS LIST (CONTINUED)

LOCATION #	PART #	DESCRIPTION
Q920	C 7614-8	DUAL DIE 200V NPN
Q921	C 7614-8	DUAL DIE 200V NPN
Q950	C 5453A1	2SA1006BR TO-220 PNP
R90	C 7102-4	4.7 OHM POSITOR
R91	C 6625-5	5.6 OHM 5W 5% METAL OXIDE
R92	C 6625-5	5.6 OHM 5W 5% METAL OXIDE
R100	C 2627-5	1.0K OHM .25W RESISTOR
R101		SELECTED
R102	C 2631-7	10K OHM .25W RESISTOR
R103	C 2631-7	10K OHM .25W RESISTOR
R104	C 4223-1	360K OHM .25W RESISTOR
R105	C 3221-6	10M OHM .25W RESISTOR
R106	C 2629-1	3.3K OHM .25W RESISTOR
R107	C 5046-5	20K OHM .25W RESISTOR
R108	C 5046-5	20K OHM .25W RESISTOR
R109	C 6402-9	51 OHM .25W RESISTOR
R110	C 4853-5	3.01K OHM .25W 1% RESISTOR
R111	C 4905-3	25.5 OHM .5W 1% RESISTOR
R112	C 6402-9	51 OHM .25W RESISTOR
R113	C 3807-2	1.8K OHM .25W RESISTOR
R114	C 2876-8	1.5K OHM .25W RESISTOR
R115	C 7679-1	150K OHM .25W 1% RESISTOR
R116	C 4869-1	137K OHM .5W 1% RESISTOR
R117	C 7955-5	50M OHM .25W RESISTOR
R118	C 5650-4	10 OHM .25W 1% RESISTOR
R119	C 5650-4	10 OHM .25W 1% RESISTOR
R121	C 4867-5	49.9 OHM .25W RESISTOR
R122	C 4867-5	49.9OHM .25W RESISTOR
R123	C 4859-2	10K OHM .25W 1% RESISTOR
R124	C 4859-2	10K OHM .25W 1% RESISTOR
R125	C 5163-8	5.1K OHM .25W RESISTOR
R126	C 2631-7	10K OHM .25W RESISTOR
R128	C 3115-0	1.4K OHM .25W 1% RESISTOR
R129	C 3115-0	1.4K OHM .25W 1% RESISTOR
R130	C 5169-5	330 OHM .25W RESISTOR
R133	C 2628-3	2.2K OHM .25W RESISTOR
R134	C 2627-5	1.0K OHM 25W RESISTOR
R135	C 4222-3	330K OHM .25 RESISTOR

7.10.SCHEMATIC PARTS LIST (CONTINUED)

LOCATION #	PART #	DESCRIPTION
R200	C 6482-1	24.9K OHM 1W RESISTOR
R201	C 6398-9	1.31K OHM .25W RESISTOR
R202	C 2627-5	1.0K OHM .25W RESISTOR
R203	C 6482-1	24.9K OHM 1W RESISTOR
R204	C 5062-2	100K OHM LINEAR TRIMPOT
R205	C 5170-3	2.2M OHM .25W RESISTOR
R207	C 6399-7	1.38K OHM .25W RESISTOR
R208	C 6482-1	24.9K OHM 1W RESISTOR
R209	C 3800-7	200 OHM .25W RESISTOR
R210	C 3800-7	200 OHM .25W RESISTOR
R211	C 6400-3	232 OHM .25W 1% RESISTOR
R212	C 6400-3	232 OHM .25W 1% RESISTOR
R213	C 4852-7	2.49K OHM .25W 1% RESISTOR
R214	C 3686-0	4.99K OHM .25W 1% RESISTOR
R215	C 3686-0	4.99K OHM .25W 1% RESISTOR
R216	C 2627-5	1.0K OHM .25W RESISTOR
R217	C 3686-0	4.99K OHM .25W 1% RESISTOR
R218	C 3686-0	4.99K OHM .25W 1% RESISTOR
R219	C 4852-7	2.49K OHM .25W 1% RESISTOR
R220	C 6400-3	232 OHM .25W 1% RESISTOR
R221	C 6400-3	232 OHM .25W 1% RESISTOR
R222	C 2872-7	100 OHM .25W RESISTOR
R223	C 4852-7	2.49K OHM .25W 1% RESISTOR
R224	C 2874-3	560 OHM .25W RESISTOR
R225	C 1011-3	47 OHM .25W RESISTOR
R226	C 6401-1	24K OHM 1W 1% RESISTOR
R227	C 2874-3	560 OHM .25W RESISTOR
R228	C 1011-3	47 OHM .25W RESISTOR
R229	C 2872-7	100 OHM .25W RESISTOR
R230	C 2872-7	100 OHM .25W RESISTOR
R231	C 6402-9	51 OHM .25W RESISTOR
R232	C 6403-7	51K OHM 1W RESISTOR
R233	C 6403-7	51K OHM 1W RESISTOR
R234	C 5062-2	100K OHM LINEAR TRIMPOT
R235	C 3621-7	91K OHM .25W RESISTOR
R236	C 6489-6	10K LINEAR PIHER POT
R237	C 2627-5	1.0K OHM .25W RESISTOR
R238	C 5039-0	100 OHM .25W 1% RESISTOR
R239	C 5039-0	100 OHM .25W 1% RESISTOR
R240	C 6403-7	51K OHM 1W RESISTOR

7.10.SCHEMATIC PARTS LIST (CONTINUED)

LOCATION #	PART #	DESCRIPTION
R241	C 2880-0	47K OHM .25W RESISTOR
R242	C 4852-7	2.49K OHM .25W 1% RESISTOR
R243	C 5169-5	330 OHM .25W RESISTOR
R244	C 1011-3	47 OHM .25W RESISTOR
R245	C 3753-8	10 OHM .25W RESISTOR
R246	C 2876-8	1.5K OHM .25W RESISTOR
R247	C 2876-8	1.5K OHM .25W RESISTOR
R248	C 3619-1	6.2K OHM .25W RESISTOR
R249	C 3619-1	6.2K OHM .25W RESISTOR
R250	C 2630-9	3.9K OHM .25W RESISTOR
R251	C 2630-9	3.9K OHM .25W RESISTOR
R252	C 4346-0	33K OHM .25W RESISTOR
R253	C 3804-9	2K OHM .25W RESISTOR
R254	C 2631-7	10K OHM .25W RESISTOR
R300	C 2626-7	470 OHM .25W RESISTOR
R301	C 2626-7	470 OHM .25W RESISTOR
R302	C 2626-7	470 OHM .25W RESISTOR
R303	C 7282-4	88.7K OHM 5W 1% RESISTOR
R304	C 2885-9	270K OHM .25W RESISTOR
R305	C 5062-2	100K OHM LINEAR TRIMPOT
R306	C 5039-0	100 OHM .25W 1% RESISTOR
R307	C 4859-2	10K OHM .25W 1% RESISTOR
R308	C 5235-4	110 OHM .25W RESISTOR
R309	C 3939-3	4.7K OHM .25W RESISTOR
R310	C 4225-6	470K OHM .25W RESISTOR
R311	C 4225-6	470K OHM .25W RESISTOR
R312	C 3220-8	5.6K OHM .25W RESISTOR
R313	C 5662-9	16.2K OHM .25W 1% RESISTOR
R314	C 6402-9	51 OHM .25W RESISTOR
R315	C 4859-2	10K OHM .25W 1% RESISTOR
R316	C 4859-2	10K OHM .25W 1% RESISTOR
R317	C 6402-9	51 OHM .25W RESISTOR
R318	C 6404-5	82.5K OHM .25W 1% RESISTOR
R319	C 6405-2	11K OHM .25W 1% RESISTOR
R320	C 4859-2	10K OHM .25W 1% RESISTOR
R321	C 5039-0	100 OHM .25W 1% RESISTOR
R322	C 7282-4	88.7K OHM .5W 1% RESISTOR
R323	C 5039-0	100 OHM .25W 1% RESISTOR
R325	C 5662-9	16.2K OHM .25W 1% RESISTOR

7.10.SCHEMATIC PARTS LIST (CONTINUED)

LOCATION #	PART #	DESCRIPTION
R325	C 5662-9	16.2K OHM .25W 1% RESISTOR
R326	C 5235-4	110 OHM .25W RESISTOR
R327	C 3220-8	5.6K OHM .25W RESISTOR
R328	C 4225-6	470K OHM .25W RESISTOR
R329	C 2631-7	10K OHM .25W RESISTOR
R330	C 4225-6	470K OHM .25W RESISTOR
R331	C 3939-3	4.7K OHM .25W RESISTOR
R332	C 6406-0	8.15K OHM.25W 1% RESISTOR
R333	C 2885-9	270K OHM .25W RESISTOR
R334	C 5062-2	100K OHM LINEAR TRIMPOT
R335	C 5165-3	27K OHM .25W RESISTOR
R336	C 2626-7	470 OHM .25W RESISTOR
R337	C 2626-7	470 OHM .25W RESISTOR
R338	C 2626-7	470 OHM .25W RESISTOR
R339	C 6405-2	11K OHM .25W 1% RESISTOR
R340	C 6404-5	82.5K OHM .25W 1% RESISTOR
R341	C 4859-2	10K OHM .25W 1% RESISTOR
R342	C 6402-9	51 OHM .25W RESISTOR
R343	C 4859-2	10K OHM .25W 1% RESISTOR
R344	C 4859-2	10K OHM .25W 1% RESISTOR
R345	C 6402-9	51 OHM .25W RESISTOR
R346	C 5165-3	27K OHM .25W RESISTOR
R347	C 5039-0	100 OHM .25W 1% RESISTOR
R348	C 2631-7	10K OHM .25W RESISTOR
R350	C 6090-2	62K OHM .25W RESISTOR
R351	C 2632-5	15K OHM .25W RESISTOR
R352	C 6407-8	39K OHM .25W RESISTOR
R353	C 6407-8	39K OHM .25W RESISTOR
R354	C 6090-2	62K OHM .25W RESISTOR
R355	C 3939-3	4.7K OHM .25W RESISTOR
R357	C 3804-9	2K OHM .25W RESISTOR
R358	C 5165-3	27K OHM .25W RESISTOR
R359	C 5270-1	30K OHM .25W RESISTOR
R400	C 7852-4	2.5K OHM 5W 5% WIREWOUND
R401	C 7852-4	2.5K OHM 5W 5% WIREWOUND
R402	C 7441-6	90.9K OHM .25W 1% RESISTOR
R403	C 5707-2	100K OHM .25W 1% RESISTOR
R404	C 7440-8	27.4K OHM .25W 1% RESISTOR

7.10.SCHEMATIC PARTS LIST (CONTINUED)

LOCATION #	PART #	DESCRIPTION
R405		N/A
R406	C 5707-2	100K OHM .25W 1% RESISTOR
R407	C 7441-6	90.9K OHM .25W 1% RESISTOR
R408	C 5707-2	100K OHM .25W 1% RESISTOR
R409	C 7440-8	27.4K OHM .25W 1% RESISTOR
R410		N/A
R411	C 5707-2	100K OHM .25W 1% RESISTOR
R412	C 6317-9	953 OHM .25W 1% RESISTOR
R413	C 6317-9	953 OHM .25W 1% RESISTOR
R414	C 4850-1	1K OHM .25W 1% RESISTOR
R415	C 4850-1	1K OHM .25W 1% RESISTOR
R416	C 2631-7	10K OHM .25W RESISTOR
R417	C 5975-5	680 OHM .25W RESISTOR
R418	C 3198-6	1.0M OHM .25W RESISTOR
R419	C 3939-3	4.7K OHM .25W RESISTOR
R420	C 2632-5	15K OHM .25W RESISTOR
R421	C 2873-5	180 OHM .25W RESISTOR
R422	C 4167-0	43K OHM .25W RESISTOR
R423	C 3804-9	2K OHM .25W RESISTOR
R424	C 6090-2	62K OHM .25W RESISTOR
R425	C 3622-5	200K OHM .25W RESISTOR
R426	C 7654-4	3.9M OHM .25W RESISTOR
R427	C 3620-9	68K OHM .25W RESISTOR
R428	C 2883-4	100K OHM .25W RESISTOR
R500	C 2631-7	10K OHM .25W RESISTOR
R501	C 6407-8	39K OHM .25W RESISTOR
R502	C 2631-7	10K OHM .25W RESISTOR
R503	C 3939-3	4.7K OHM .25W RESISTOR
R504	C 2632-5	15K OHM .25W RESISTOR
R505	C 2631-7	10K OHM .25W RESISTOR
R506	C 5168-7	2.7K OHM .25W RESISTOR
R507	C 2883-4	100K OHM .25W RESISTOR
R508	C 3622-5	200K OHM .25W RESISTOR
R509	C 2632-5	15K OHM .25W RESISTOR
R510	C 5168-7	2.7K OHM .25W RESISTOR
R511	C 5270-1	30K OHM .25W RESISTOR
R512	C 6489-6	10K LINEAR PIHER POT
R513	C 2881-8	51K OHM .25W RESISTOR
R514	C 2627-5	1.0K OHM .25W RESISTOR

7.10.SCHEMATIC PARTS LIST (CONTINUED)

LOCATION #	PART #	DESCRIPTION
R515	C 2627-5	1.0K OHM .25W RESISTOR
R516	C 3302-4	22K OHM .25W RESISTOR
R517	C 3622-5	200K OHM .25W RESISTOR
R518	C 4236-3	1.8M OHM .25W RESISTOR
R519	C 2883-4	100K OHM .25W RESISTOR
R520	C 4219-9	220K OHM .25W RESISTOR
R521	C 2883-4	100K OHM .25W RESISTOR
R522	C 2627-5	1.0K OHM .25W RESISTOR
R523	C 2632-5	15K OHM .25W RESISTOR
R524	C 5168-7	2.7K OHM .25W RESISTOR
R525	C 4220-7	240K OHM .25W RESISTOR
R527	C 2876-8	1.5K OHM .25W RESISTOR
R528	C 2880-0	47K OHM .25W RESISTOR
R529	C 5168-7	2.7K OHM .25W RESISTOR
R530	C 5168-7	2.7K OHM .25W RESISTOR
R531	C 2628-3	2.2K OHM .25W RESISTOR
R532	C 3302-4	22K OHM .25W RESISTOR
R533	C 3302-4	22K OHM .25W RESISTOR
R534	C 3302-4	22K OHM .25W RESISTOR
R535	C 2872-7	100 OHM .25W RESISTOR
R536	C 2873-5	180 OHM .25W RESISTOR
R537	C 6129-8	91 OHM .25W RESISTOR
R538	C 6129-8	91 OHM .25W RESISTOR
R539	C 2627-5	1.0K OHM .25W RESISTOR
R540	C 2626-7	470 OHM .25W RESISTOR
R600	C 3931-0	12 OHM 2W RESISTOR
R601	C 3583-9	.33 OHM 5W RESISTOR
R602	C 3583-9	.33 OHM 5W RESISTOR
R603	C 3583-9	.33 OHM 5W RESISTOR
R604	C 3583-9	.33 OHM 5W RESISTOR
R605	C 3583-9	.33 OHM 5W RESISTOR
R606	C 3583-9	.33 OHM 5W RESISTOR
R607	C 3583-9	.33 OHM 5W RESISTOR
R608	C 3583-9	.33 OHM 5W RESISTOR
R609	C 3583-9	.33 OHM 5W RESISTOR
R610	C 3583-9	.33 OHM 5W RESISTOR
R611	C 3931-0	12 OHM 2W RESISTOR
R612	C 2872-7	100 OHM .25W RESISTOR
R613	C 2872-7	100 OHM .25W RESISTOR
R614	C 3931-0	12 OHM 2W RESISTOR

7.10.SCHEMATIC PARTS LIST (CONTINUED)

LOCATION #	PART #	DESCRIPTION
R615	C 3583-9	.33 OHM 5W RESISTOR
R616	C 3583-9	.33 OHM 5W RESISTOR
R617	C 3583-9	.33 OHM 5W RESISTOR
R618	C 3583-9	.33 OHM 5W RESISTOR
R619	C 3583-9	.33 OHM 5W RESISTOR
R620	C 3583-9	.33 OHM 5W RESISTOR
R621	C 3583-9	.33 OHM 5W RESISTOR
R622	C 3583-9	.33 OHM 5W RESISTOR
R623	C 3583-9	.33 OHM 5W RESISTOR
R624	C 3583-9	.33 OHM 5W RESISTOR
R625	C 3931-0	12 OHM 2W RESISTOR
R626	C 3931-0	12 OHM 2W RESISTOR
R627	C 3931-0	12 OHM 2W RESISTOR
R650	C 3960-9	82 OHM .25W RESISTOR
R651	C 3672-0	2K OHM HELIPOT TRIM
R652	C 3803-1	750 OHM .25W RESISTOR
R653	C 2627-5	1K OHM .25W RESISTOR
R654	C 6517-4	24 OHM .25W RESISTOR
R655	C 3753-8	10 OHM .25W RESISTOR
R656	C 6089-4	5.6 OHM .25W RESISTOR
R700	C 3931-0	12 OHM 2W RESISTOR
R701	C 3583-9	.33 OHM 5W RESISTOR
R702	C 3583-9	.33 OHM 5W RESISTOR
R703	C 3583-9	.33 OHM 5W RESISTOR
R704	C 3583-9	.33 OHM 5W RESISTOR
R705	C 3583-9	.33 OHM 5W RESISTOR
R706	C 3583-9	.33 OHM 5W RESISTOR
R707	C 3583-9	.33 OHM 5W RESISTOR
R708	C 3583-9	.33 OHM 5W RESISTOR
R709	C 3583-9	.33 OHM 5W RESISTOR
R710	C 3583-9	.33 OHM 5W RESISTOR
R711	C 3583-9	.33 OHM 5W RESISTOR
R712	C 3583-9	.33 OHM 5W RESISTOR
R713	C 3583-9	.33 OHM 5W RESISTOR
R714	C 3583-9	.33 OHM 5W RESISTOR
R715	C 3583-9	.33 OHM 5W RESISTOR
R716	C 3583-9	.33 OHM 5W RESISTOR
R717	C 3583-9	.33 OHM 5W RESISTOR
R718	C 3583-9	.33 OHM 5W RESISTOR
R719	C 3583-9	.33 OHM 5W RESISTOR

7.10.SCHEMATIC PARTS LIST (CONTINUED)

LOCATION #	PART #	DESCRIPTION
R720	C 3583-9	.33 OHM 5W RESISTOR
R721	C 3931-0	12 OHM 2W RESISTOR
R722	C 2872-7	100 OHM 25W RESISTOR
R723	C 2872-7	100 OHM 25W RESISTOR
R724	C 3583-9	.33 OHM 5W RESISTOR
R725	C 3583-9	.33 OHM 5W RESISTOR
R726	C 3583-9	.33 OHM 5W RESISTOR
R727	C 3583-9	.33 OHM 5W RESISTOR
R728	C 3583-9	.33 OHM 5W RESISTOR
R729	C 3583-9	.33 OHM 5W RESISTOR
R730	C 3583-9	.33 OHM 5W RESISTOR
R731	C 3583-9	.33 OHM 5W RESISTOR
R732	C 3583-9	.33 OHM 5W RESISTOR
R733	C 3583-9	.33 OHM 5W RESISTOR
R734	C 3931-0	12 OHM 2W RESISTOR
R735	C 3583-9	.33 OHM 5W RESISTOR
R736	C 3583-9	.33 OHM 5W RESISTOR
R737	C 3583-9	.33 OHM 5W RESISTOR
R738	C 3583-9	.33 OHM 5W RESISTOR
R739	C 3583-9	.33 OHM 5W RESISTOR
R740	C 3583-9	.33 OHM 5W RESISTOR
R741	C 3583-9	.33 OHM 5W RESISTOR
R742	C 3583-9	.33 OHM 5W RESISTOR
R743	C 3583-9	.33 OHM 5W RESISTOR
R744	C 3583-9	.33 OHM 5W RESISTOR
R745	C 3931-0	12 OHM 2W RESISTOR
R746	C 3931-0	12 OHM 2W RESISTOR
R747	C 3931-0	12 OHM 2W RESISTOR
R750	C 1011-3	47.0 OHM .25W RESISTOR
R751	C 6089-4	5.6 OHM .25W RESISTOR
R752	C 5038-2	39.0 OHM .25W RESISTOR
R800	C 3931-0	12 OHM 2W RESISTOR
R801	C 3583-9	.33 OHM 5W RESISTOR
R802	C 3583-9	.33 OHM 5W RESISTOR
R803	C 3583-9	.33 OHM 5W RESISTOR
R804	C 3583-9	.33 OHM 5W RESISTOR
R805	C 3583-9	.33 OHM 5W RESISTOR
R806	C 3583-9	.33 OHM 5W RESISTOR
R807	C 3583-9	.33 OHM 5W RESISTOR

7.10.SCHEMATIC PARTS LIST (CONTINUED)

LOCATION #	PART #	DESCRIPTION
R808	C 3583-9	.33 OHM 5W RESISTOR
R809	C 3583-9	.33 OHM 5W RESISTOR
R810	C 3583-9	.33 OHM 5W RESISTOR
R811	C 3931-0	12 OHM 2W RESISTOR
R812	C 5342-8	236 OHM .5W 1% RESISTOR (USE WITH BLUE U800.)
R812	C 5343-6	227 OHM 5W 1% RESISTOR (USE WITH GREEN U800.)
R812	C 5344-4	218 OHM .5W 1% RESISTOR (USE WITH YELLOW U800.)
R813	C 2872-7	100 OHM .25W RESISTOR
R814	C 2872-7	100 OHM .25W RESISTOR
R815	C 3931-0	12 OHM 2W RESISTOR
R816	C 5662-9	16.2K OHM .25W 1% RESISTOR
R817	C 3583-9	.33 OHM 5W RESISTOR
R818	C 5662-9	16.2K OHM .25W 1% RESISTOR
R819	C 3583-9	.33 OHM 5W RESISTOR
R820	C 3583-9	.33 OHM 5W RESISTOR
R821	C 3583-9	.33 OHM 5W RESISTOR
R822	C 3583-9	.33 OHM 5W RESISTOR
R823	C 3583-9	.33 OHM 5W RESISTOR
R824	C 3583-9	.33 OHM 5W RESISTOR
R825	C 3583-9	.33 OHM 5W RESISTOR
R826	C 3583-9	.33 OHM 5W RESISTOR
R827	C 3583-9	.33 OHM 5W RESISTOR
R828	C 3931-0	12 OHM 2W RESISTOR
R829	C 3931-0	12 OHM 2W RESISTOR
R850	C 5168-7	2.7K OHM .25W RESISTOR
R851	C 1011-3	47 OHM .25W RESISTOR
R852	C 5168-7	2.7K OHM .25W RESISTOR
R853	C 3672-0	2K OHM HELIPOT TRIM
R854	C 3803-1	750 OHM .25W RESISTOR
R855	C 2627-5	1K OHM .25W RESISTOR
R856	C 6517-4	24 OHM .25W RESISTOR
R857	C 2857-8	2.7 OHM 5W RESISTOR
R858	C 2857-8	2.7 OHM 5W RESISTOR
R900	C 3931-0	12 OHM 2W RESISTOR
R901	C 3583-9	.33 OHM 5W RESISTOR
R902	C 3583-9	.33 OHM 5W RESISTOR
R903	C 3583-9	.33 OHM 5W RESISTOR
R904	C 3583-9	.33 OHM 5W RESISTOR

7.10.SCHEMATIC PARTS LIST (CONTINUED)

LOCATION #	PART #	DESCRIPTION
R905	C 3583-9	.33 OHM 5W RESISTOR
R906	C 3583-9	.33 OHM 5W RESISTOR
R907	C 3583-9	.33 OHM 5W RESISTOR
R908	C 3583-9	.33 OHM 5W RESISTOR
R909	C 3583-9	.33 OHM 5W RESISTOR
R910	C 3583-9	.33 OHM 5W RESISTOR
R911	C 3583-9	.33 OHM 5W RESISTOR
R912	C 3583-9	.33 OHM 5W RESISTOR
R913	C 3583-9	.33 OHM 5W RESISTOR
R914	C 3583-9	.33 OHM 5W RESISTOR
R915	C 3583-9	.33 OHM 5W RESISTOR
R916	C 3583-9	.33 OHM 5W RESISTOR
R917	C 3583-9	.33 OHM 5W RESISTOR
R918	C 3583-9	.33 OHM 5W RESISTOR
R919	C 3583-9	.33 OHM 5W RESISTOR
R920	C 3583-9	.33 OHM 5W RESISTOR
R921	C 3931-0	12 OHM 2W RESISTOR
R922	C 2872-7	100 OHM .25W RESISTOR
R923	C 5342-8	236 OHM .5W 1% RESISTOR (USE WITH BLUE U900.)
R923	C 5343-6	227 OHM .5W 1% RESISTOR (USE WITH GREEN U900.)
R923	C 5344-4	218 OHM .5W 1% RESISTOR (USE WITH YELLOW U900.)
R924	C 2872-7	100 OHM .25W RESISTOR
R925	C 3583-9	.33 OHM 5W RESISTOR
R926	C 3583-9	.33 OHM 5W RESISTOR
R927	C 3583-9	.33 OHM 5W RESISTOR
R928	C 3583-9	.33 OHM 5W RESISTOR
R929	C 3583-9	.33 OHM 5W RESISTOR
R930	C 3583-9	.33 OHM 5W RESISTOR
R931	C 3583-9	.33 OHM 5W RESISTOR
R932	C 3583-9	.33 OHM 5W RESISTOR
R933	C 3583-9	.33 OHM 5W RESISTOR
R934	C 3583-9	.33 OHM 5W RESISTOR
R935	C 3931-0	12 OHM 2W RESISTOR
R936	C 3583-9	.33 OHM 5W RESISTOR
R937	C 3583-9	.33 OHM 5W RESISTOR
R938	C 3583-9	.33 OHM 5W RESISTOR
R939	C 3583-9	.33 OHM 5W RESISTOR
R940	C 3583-9	.33 OHM 5W RESISTOR
R941	C 3583-9	.33 OHM 5W RESISTOR

7.10.SCHEMATIC PARTS LIST (CONTINUED)

LOCATION #	PART #	DESCRIPTION
R942	C 3583-9	.33 OHM 5W RESISTOR
R943	C 3583-9	.33 OHM 5W RESISTOR
R944	C 3583-9	.33 OHM 5W RESISTOR
R945	C 3583-9	.33 OHM 5W RESISTOR
R946	C 3931-0	12 OHM 2W RESISTOR
R947	C 3931-0	12 OHM 2W RESISTOR
R950	C 5168-7	2.7K OHM .25W RESISTOR
R951	C 2872-7	100 OHM .25W RESISTOR
R952	C 5168-7	2.7K OHM .25W RESISTOR
R953	C 5038-2	39 OHM .25W RESISTOR
R954	C 2857-8	2.7 OHM .5W RESISTOR
R955	C 2857-8	2.7 OHM .5W RESISTOR
S1	SC 7363-2	DPDT GOLD CONTACT PC SLIDE SW
S2	C 7106-5	DPDT ALCO AS2EG-PC
T2	D 6796-3	TRANSFORMER, MAIN POWER
T2	D 6519-4	TRANSFORMER, ISA CONTROL
T100	C 6420-1	.025 SQ. POST
T103	C 6420-1	.025 SQ. POST
T200	C 6420-1	.025 SQ. POST
T201	C 6420-1	.025 SQ. POST
T202	C 6420-1	.025 SQ. POST
T300	C 6420-1	.025 SQ. POST
T301	C 6420-1	.025 SQ. POST
T302	C 6420-1	.025 SQ. POST
T303	C 6420-1	.025 SQ. POST
TS1	C 6737-8	SPST NC THERMAL SWITCH 150OC
TS2	C 6737-8	SPST NC THERMAL SWITCH 150OC
U100	C 6375-7	HCPL-2200 OP ISOLATOR
U101	C 6375-7	HCPL-2200 OP ISOLATOR
U102	C 6375-7	HCPL-2200 OP ISOLATOR
U103	C 6375-7	HCPL-2200 OP ISOLATOR
U104	C 6375-7	HCPL-2200 OP ISOLATOR
U105	C 6375-7	HCPL-2200 OP ISOLATOR
U106	C 6375-7	HCPL-2200 OP ISOLATOR
U107	C 6375-7	HCPL-2200 OP ISOLATOR
U108	C 6375-7	HCPL-2200 OP ISOLATOR
U109	C 6375-7	HCPL-2200 OP ISOLATOR

7.10.SCHEMATIC PARTS LIST (CONTINUED)

LOCATION #	PART #	DESCRIPTION
U110	C 6375-7	HCPL-2200 OP ISOLATOR
U111	C 6375-7	HCPL-2200 OP ISOLATOR
U112	C 6375-7	HCPL-2200 OP ISOLATOR
U113	C 6375-7	HCPL-2200 OP ISOLATOR
U114	C 6375-7	HCPL-2200 OP ISOLATOR
U115	C 6375-7	HCPL-2200 OP ISOLATOR
U116	C 6375-7	HCPL-2200 OP ISOLATOR
U117	C 6375-7	HCPL-2200 OP ISOLATOR
U118	C 7049-7	OCTAL D FLIP/FLOP 74LS273
U119	C 7049-7	OCTAL D FLIP/FLOP 74LS273
U120	A10915-1	MOD, DAC 16B EMULATOR
U121	C 7012-5	LT102IDCN8-10 IC
U122	C 7078-6	ADOP37FN OP AMP
U124	C 5798-1	74LS123 DUAL MLTVBRT
U125	C 5772-6	74LS04N HEX INVERTER
U126	C 7075-2	OP27GN8 LINEAR TECH OP AMP
U127	C 7107-3	LF13331 QUAD FET SWITCH
U128	C 5881-5	NE5532N DUAL OP AMP
U130	C 7075-2	OP27GN8 LINEAR TECH OP AMP
U131	C 7075-2	OP27GN8 LINEAR TECH OP AMP
U132	C 4345-2	LM339N VOLT COMPARATR
U133	C 7075-2	OP27GN8 LINEAR TECH OP AMP
U200	C 6421-9	TI TL011CLP CURRENT SOURCE
U201	C 6421-9	TI TL011CLP CURRENT SOURCE
U202	C 7621-3	LF357 OP AMP
U203	C 7621-3	LF357 OP AMP
U300	C 4696-8	TLO74CN QUAD OP AMP
U301	C 4160-5	HA1-4741-5 QUAD OP AMP
U302	C 4696-8	TLO74CN QUAD OP AMP
U303	C 6411-0	H11C 2 OPTO SCR
U304	C 4345-2	LM339N VOLT COMPARATOR
U400	C 5095-2	MC7815CT +15V REGULATOR
U401	C 5096-0	MC7915CT -15V REGULATOR
U402	C 5094-5	MC7805CT +5V REGULATOR
U403	C 7444-0	LM393 DUAL OP AMP
U404	C 7445-7	ICM 7555 TIMER

7.10.SCHEMATIC PARTS LIST (CONTINUED)

LOCATION #	PART #	DESCRIPTION
U405	C 4345-2	LM339N VOLT COMPARATOR
U500	C 4345-2	LM339N VOLT COMPARATOR
U501	C 4345-2	LM339N VOLT COMPARATOR
U502	C 6375-7	HCPL-2200 OP ISOLATOR
U503	C 6416-9	AM2631PC RS422 QUAD LINE DRIVER
U800	C 5826-0	LM334Z THERMAL SENSE
U900	C 5826-0	LM334Z THERMAL SENSE

7.11. EDDY CURRENT BOARD PARTS LIST

LOCATION #	PART #	DESCRIPTION
C1	C 7147-9	.47MF 50V 5% METAL CARBON AXIAL
C2	C 7146-1	2.0MF 50V 5% METAL CARBON AXIAL
C3	C 7145-3	10MF 50V 5% METAL CARBON AXIAL
C4	C 7148-7	.1MF 50V 5% METAL CARBON AXIAL
C5	C 6130-6	.1MF 50V MONO
C6	C 6130-6	.1MF 50V MONO
C7	C 5317-0	.01MF 100V 2.5% POLYPROPYLENE
J1		N/A
J2		N/A
J3	C 6419-3	SHUNT, .025" SQUARE POST
J4	C 6419-3	SHUNT, .025" SQUARE POST
J5	C 6419-3	SHUNT, .025" SQUARE POST
J6	C 6419-3	SHUNT, .025" SQUARE POST
J7	C 6419-3	SHUNT, .025" SQUARE POST
R1	C 4859-2	10K OHM .25W 1% RESISTOR
R2	C 4859-2	10K OHM .25W 1% RESISTOR
R3	C 3686-0	4.99K OHM .25W 1% RESISTOR
R4	C 3686-0	4.99K OHM .25W 1% RESISTOR
R5		N/A
R6		N/A
R8	C 5046-5	20K OHM .25W RESISTOR
R9	C 5046-5	20K OHM .25W RESISTOR
R10	C 5046-5	20K OHM .25W RESISTOR
R11	C 5046-5	20K OHM .25W RESISTOR
R12		N/A
R13	C 7286-5	17.8K OHM .25W 1% RESISTOR
R14	C 7286-5	17.8K OHM .25W 1% RESISTOR
R15	C 7286-5	17.8K OHM .25W 1% RESISTOR
R16	C 7286-5	17.8K OHM .25W 1% RESISTOR
R17	C 7156-0	500K OHM POT MULTITURN
R18	C 7156-0	500K OHM POT MULTITURN
R19	C 7156-0	500K OHM POT MULTITURN
R20	C 7156-0	500K OHM POT MULTITURN
R21	C 7157-8	5K OHM POT MULTITURN
R22	C 7157-8	5K OHM POT MULTITURN
R23	C 7157-8	5K OHM POT MULTITURN

7.11. EDDY CURRENT BOARD PARTS LIST (CONTINUED)

LOCATION #	PART #	DESCRIPTION
R24	C 7157-8	5K OHM POT MULTITURN
R25	C 4870-9	150K OHM .25W 1% RESISTOR
U1	C 6377-3	LF412A ACN LODRIFT OP AMP
U2	C 7012-5	LT102IDCN8-10 IC
U3	C 6377-3	LF412A ACN LODRIFT OP AMP
U4	C 6377-3	LF412A ACN LODRIFT OP AMP
	D 6976-1	Board, Eddy Current
	D 6977-9	Cable, Eddy Current

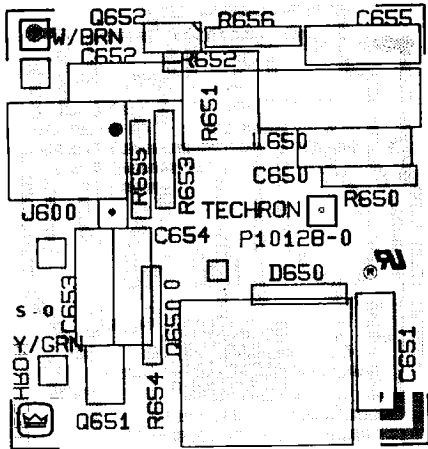

Illustration 7-5
Hi NPN Predriver Board

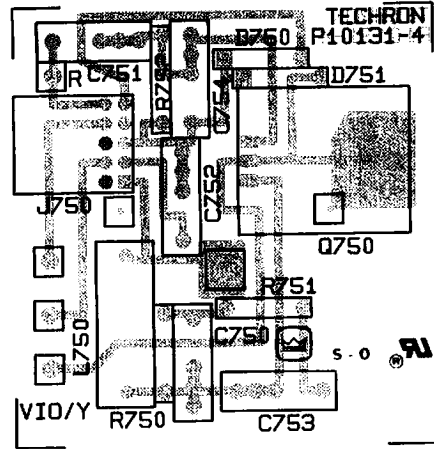

Illustration 7-6
Hi PNP Predriver Board

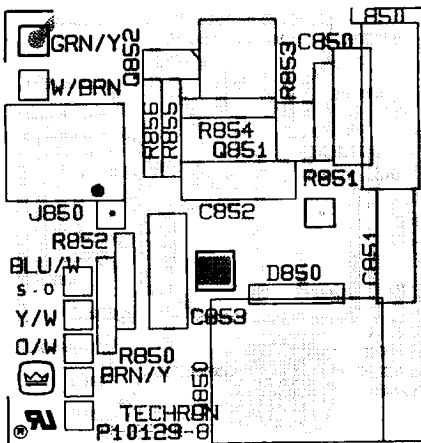

Illustration 7-7
Low NPN Predriver Board

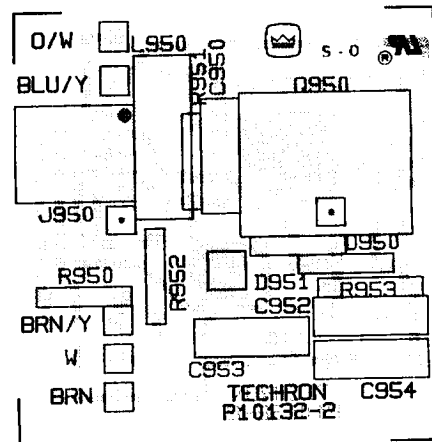

Illustration 7-8
Low PNP Predriver Board

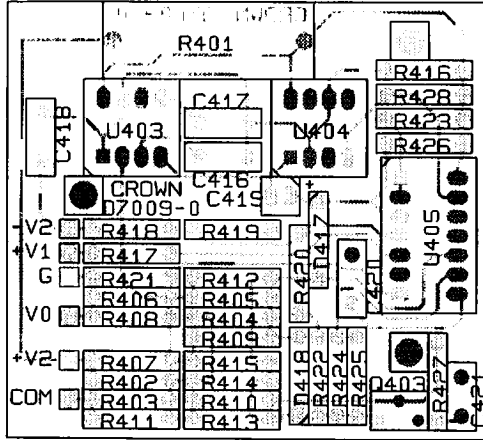

Illustration 7-9
Bi-Level Control

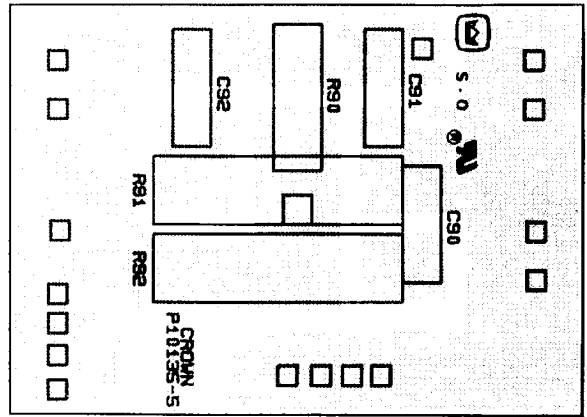

Illustration 7-10
Terminator Circuit Board

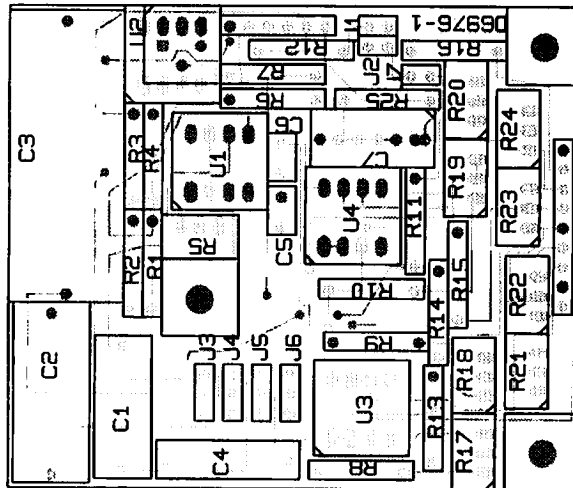

Illustration 7-11
Eddy Current Board

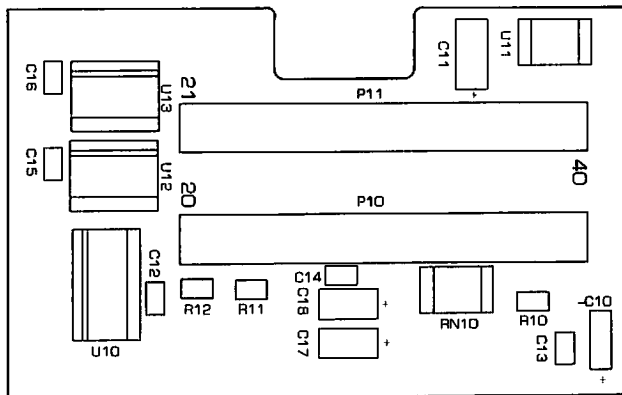

Illustration 7-60
DAC Module Emulator Board

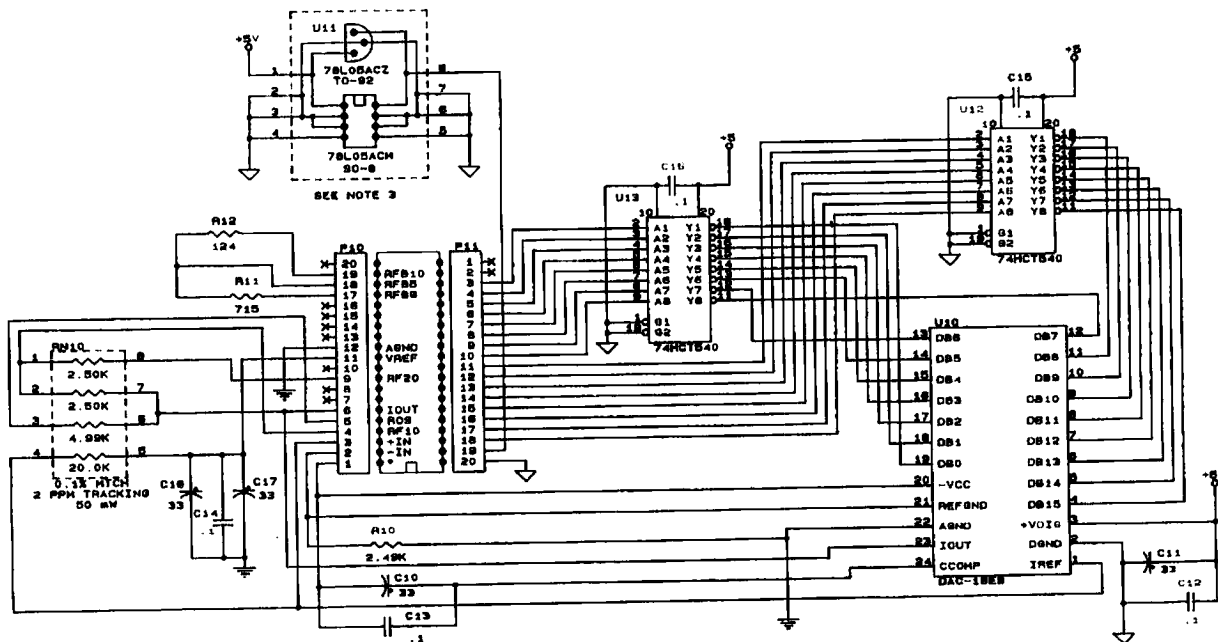

Illustration 7-61
DAC Module Schematic

APPENDIX A: CONNECTORS

A.1. J1, DIGITAL INPUT

<u>PIN</u>	<u>FUNCTION</u>
1	D4-P
2	D5-P
3	D6-P
4	D7-P
5	D8-P
6	D9-P
7	D10-P
8	D11-P
9	D12-P
10	D13-P
11	D14-P
12	D15-P (MSB)
13	DO-P LSB)
14	D1-P
15	D2-P
16	D3-P
17	SPARE
18	STROBE-P
19	OPEN
20	D4-N
21	D5-N
22	D6-N
23	D7-N
24	D8-N
25	D9-N
26	D10-N
27	D11-N
28	D12-N
29	D13-N
30	D14-N
31	D15-N (MSB)
32	DO-N (LSB)
33	D1-N
34	D2-N
35	D3-N
36	SPARE
37	STROBE-N

A.2. J2, STATUS REPORTING

<u>PIN</u>	<u>FUNCTION</u>
1	CURRENT MONITOR-P
2	FAILURE-P
3	READY-P (STANDBY)
4	OVRD-P
5	OVERTEMP-P
6	POS.TEMPERATURE SIMULATOR-P
7	NEG. TEMPERATURE SIMULATOR-P
8	STANDBY-P
9	OVRD RESET-P
10	SPARE
11	SPARE
12	SPARE
13	OPEN
14	CURRENT MONITOR-N
15	FAILURE-N
16	READY-N
17	OVRD-N
18	OVERTEMP-N
19	POS.TEMPERATURE SIMULATOR-N
20	NEG.TEMPERATURE SIMULATOR-N
21	STANDBY-N
22	OVRD RESET-N
23	SPARE
24	SPARE
25	SPARE

A.3. J3, INTERLOCK

<u>PIN</u>	<u>FUNCTION</u>
1	+ 1 SLAVE IN
2	NOT USED
3	NOT USED
4	AMPLIFIER OUTPUT
5	NOT USED
6	INTERLOCK IN
7	INTERLOCK OUT
8	OPEN
9	GROUND
10	- 1 SLAVE IN
11	GROUND
12	NOT USED
13	+ 15 V _{DC}
14	INTERLOCK COMMON
15	OVERLOAD RESET INTER.

A.4. J101, ANALOG INPUT

<u>PIN</u>	<u>FUNCTION</u>
FEMALE	NON-INVERTING
MALE	INVERTING
SHELL	GROUND

A.5. J102, CURRENT MONITOR

<u>PIN</u>	<u>FUNCTION</u>
CENTER	CURRENT MONITOR (20 AMPS/VOLT)
SHELL	GROUND

APPENDIX B: MASTER SLAVE INTERLOCK CABLE

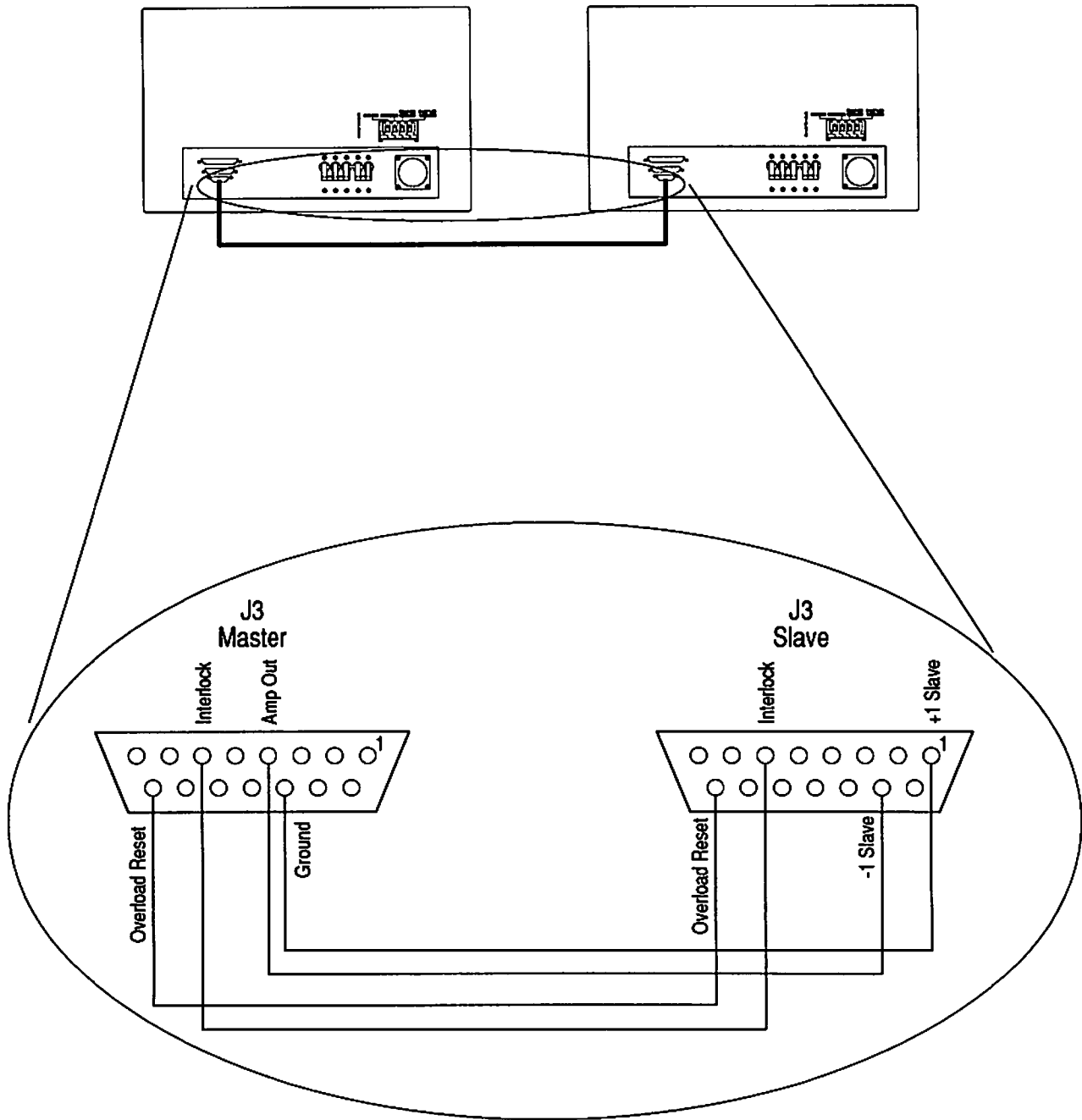

A.3. J3, INTERLOCK

<u>PIN</u>	<u>FUNCTION</u>
1	+ 1 SLAVE IN
2	NOT USED
3	NOT USED
4	AMPLIFIER OUTPUT
5	NOT USED
6	INTERLOCK IN
7	INTERLOCK OUT
8	OPEN
9	GROUND
10	- 1 SLAVE IN
11	GROUND
12	NOT USED
13	+ 15 V _{dc}
14	INTERLOCK COMMON
15	OVERLOAD RESET INTER.

A.4. J101, ANALOG INPUT

<u>PIN</u>	<u>FUNCTION</u>
FEMALE	NON-INVERTING
MALE	INVERTING
SHELL	GROUND

A.5. J102, CURRENT MONITOR

<u>PIN</u>	<u>FUNCTION</u>
CENTER	CURRENT MONITOR (20 AMPS/VOLT)
SHELL	GROUND

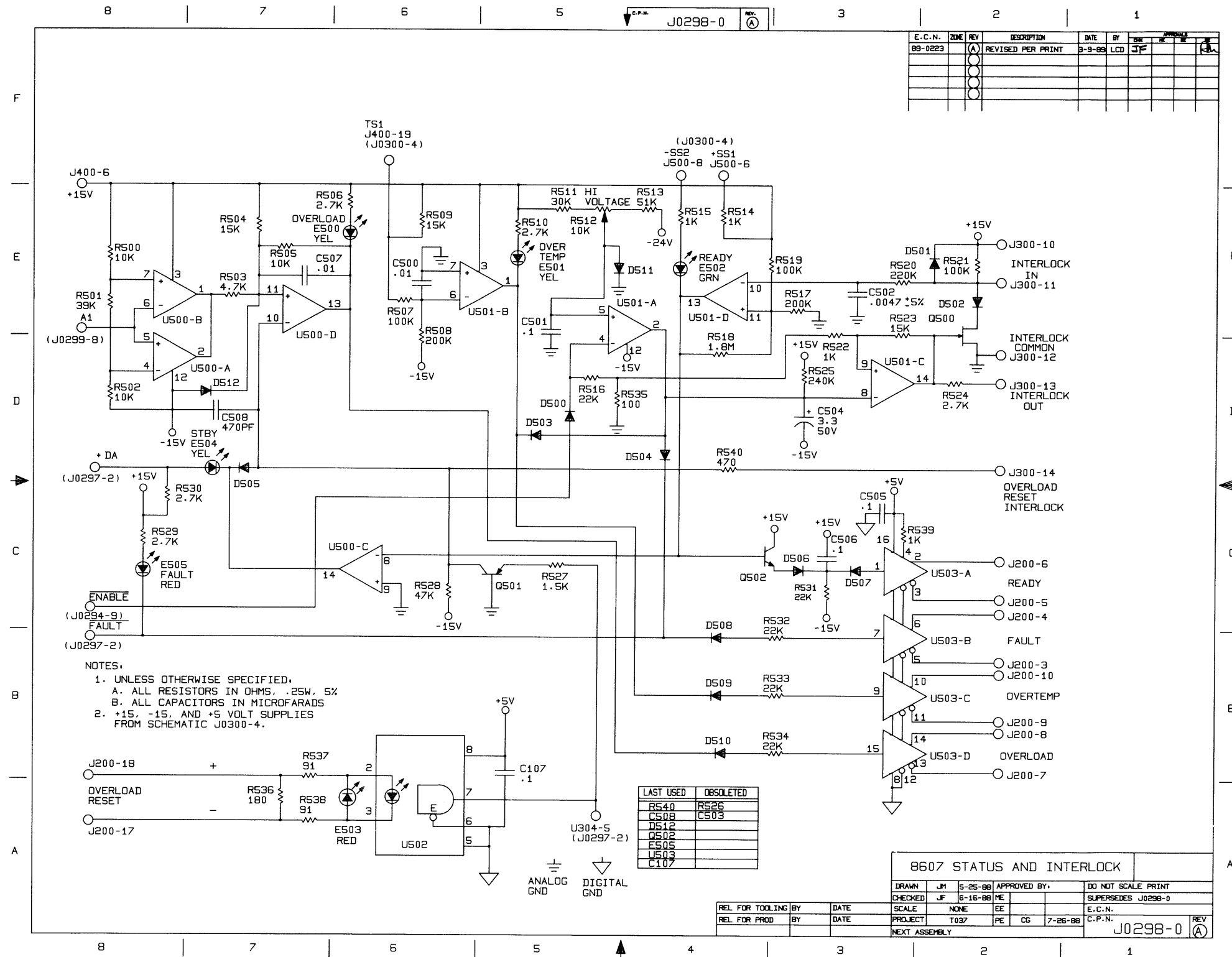

Schematic, 8607 Status and Interlock

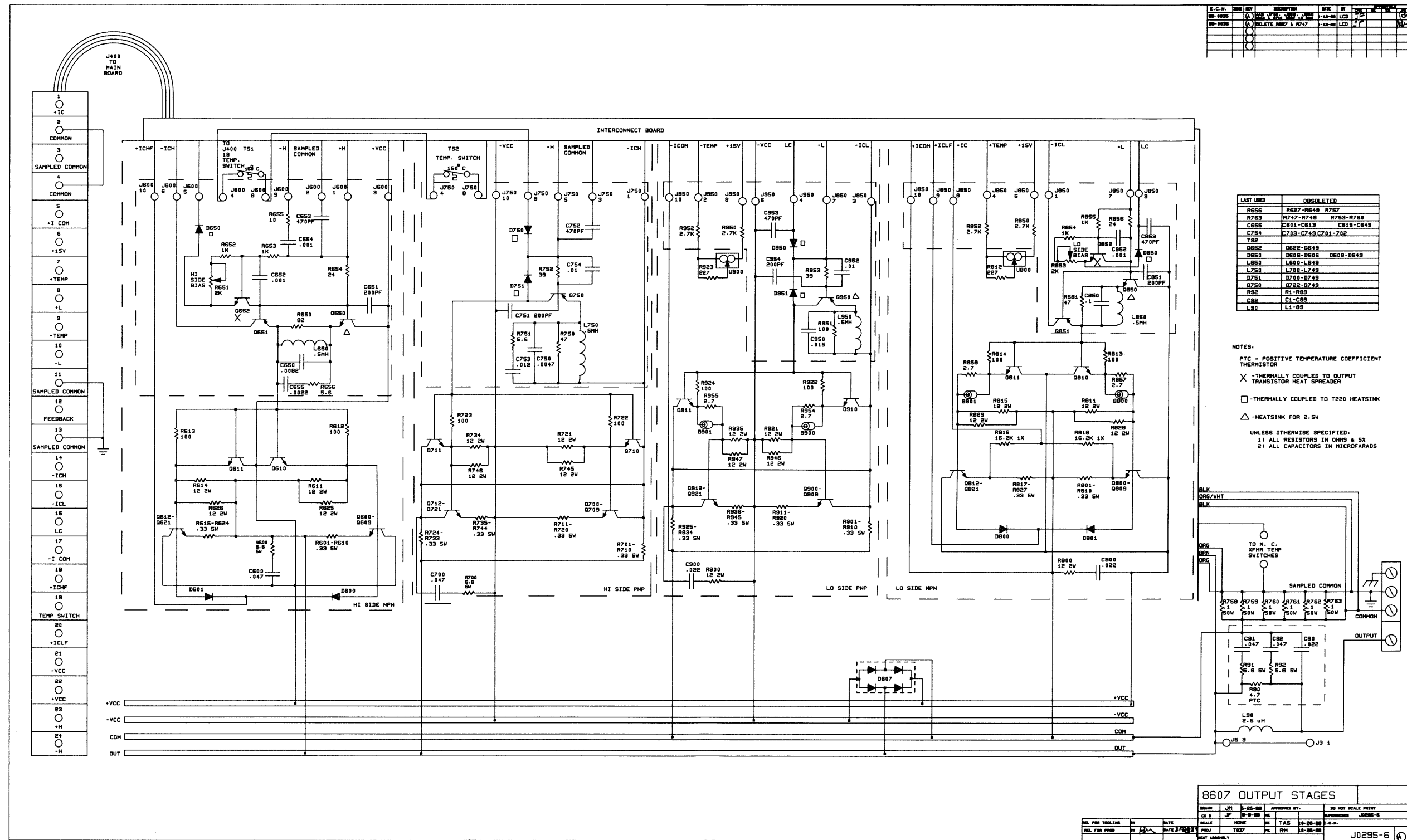

Schematic, 8607 Output Stage

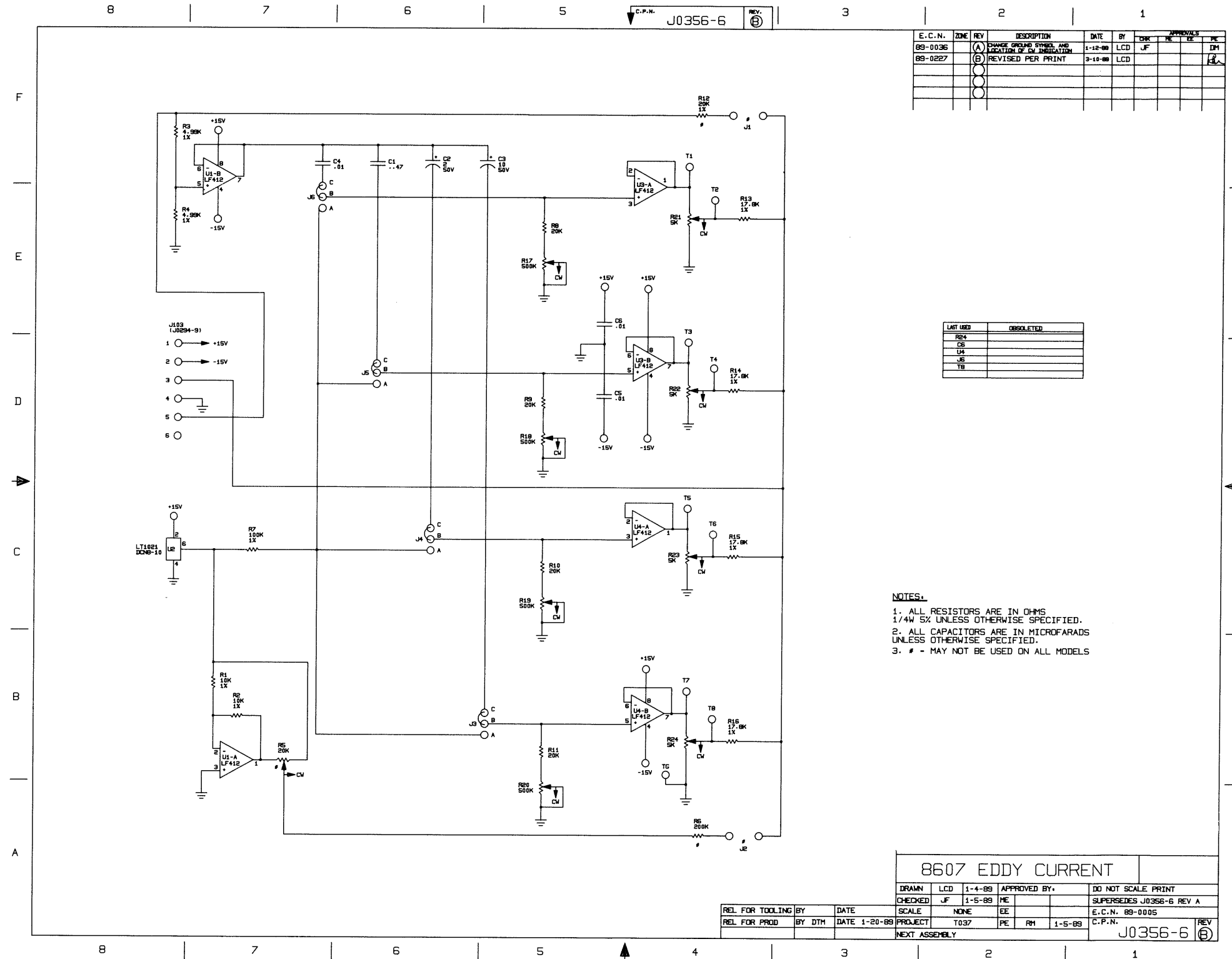

Schematic, Eddy Current Correction

6 | 5 | 4 | 3 | 2 | 1

LAST USED	OBSOLETE
R428	R400
C431	C400-415
U405	U400-402
D420	D400-416
Q403	

E.C.N.	ZONE	REV	DESCRIPTION	DATE	BY	APPROVALS			
						CHK	ME	EE	PE
89-0225		(A)	REVISED PER PRINT	9-9-89	LCD	JF			RM
89-1020		(B)	ADD C430 & C431	12-29-89	LCD	JF		R	
		(C)							
		(D)							

C.P.N. J0320-2

REV. (B)

C

B

A

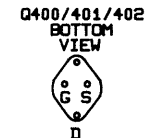
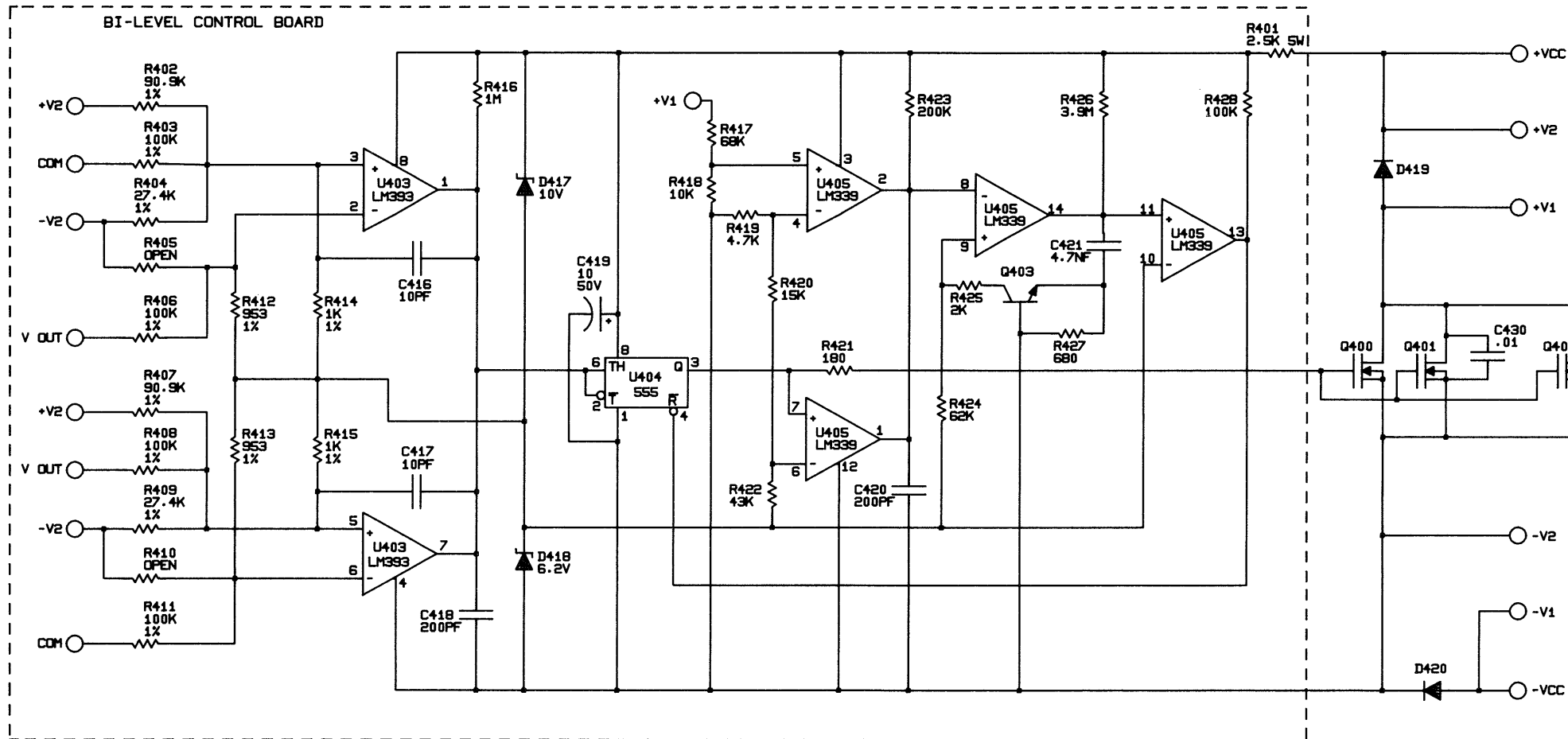

NOTES:

1. ALL RESISTORS IN OHMS .25W 5% UNLESS OTHERWISE SPECIFIED
2. ALL CAPACITORS IN MICROFARADS UNLESS OTHERWISE SPECIFIED
3. I/O CONNECTIONS:
J0295-6: COM, VOUT, +VCC, -VCC
J0300-4: +V1, -V1, +V2, -V2

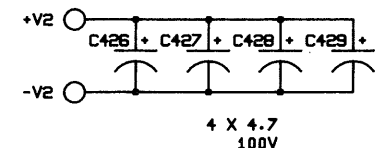
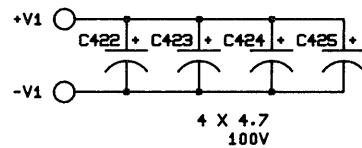

CROWN INTERNATIONAL, INC.
1718 WEST MISHAWAKA ROAD ELKHART, INDIANA 46517 PHONE (219)294-8000

BI-LEVEL CONTROLLER

DRAWN	JM	8-16-88	APPROVED BY:	DO NOT SCALE PRINT
CHECKED	JF	8-17-88	ME	SUPERSEDES J0320-2
REL FOR TOOLING	BY	DATE	SCALE	NONE
REL FOR PROD	BY RM	DATE 3-21-89	PROJECT	T013
NEXT ASSEMBLY			EE	R 1-4-90
			PE	R JONES 8-17-88
				E.C.N.
				C.P.N.
				J0320-2 (B)

6 | 5 | 4 | 3 | 2 | 1

E.C.N.	ZONE	REV	DESCRIPTION	DATE	BY	APPROVALS
						CHK TEE TPE
89-0188		(A)	CB1 WAS CB2 CB2 WAS CB1 CHANGE TITLE	2-27-88	LCD JF	RM
90-0307		(B)	C411 & C416 WERE .47	4-24-90	LCD SC	SR

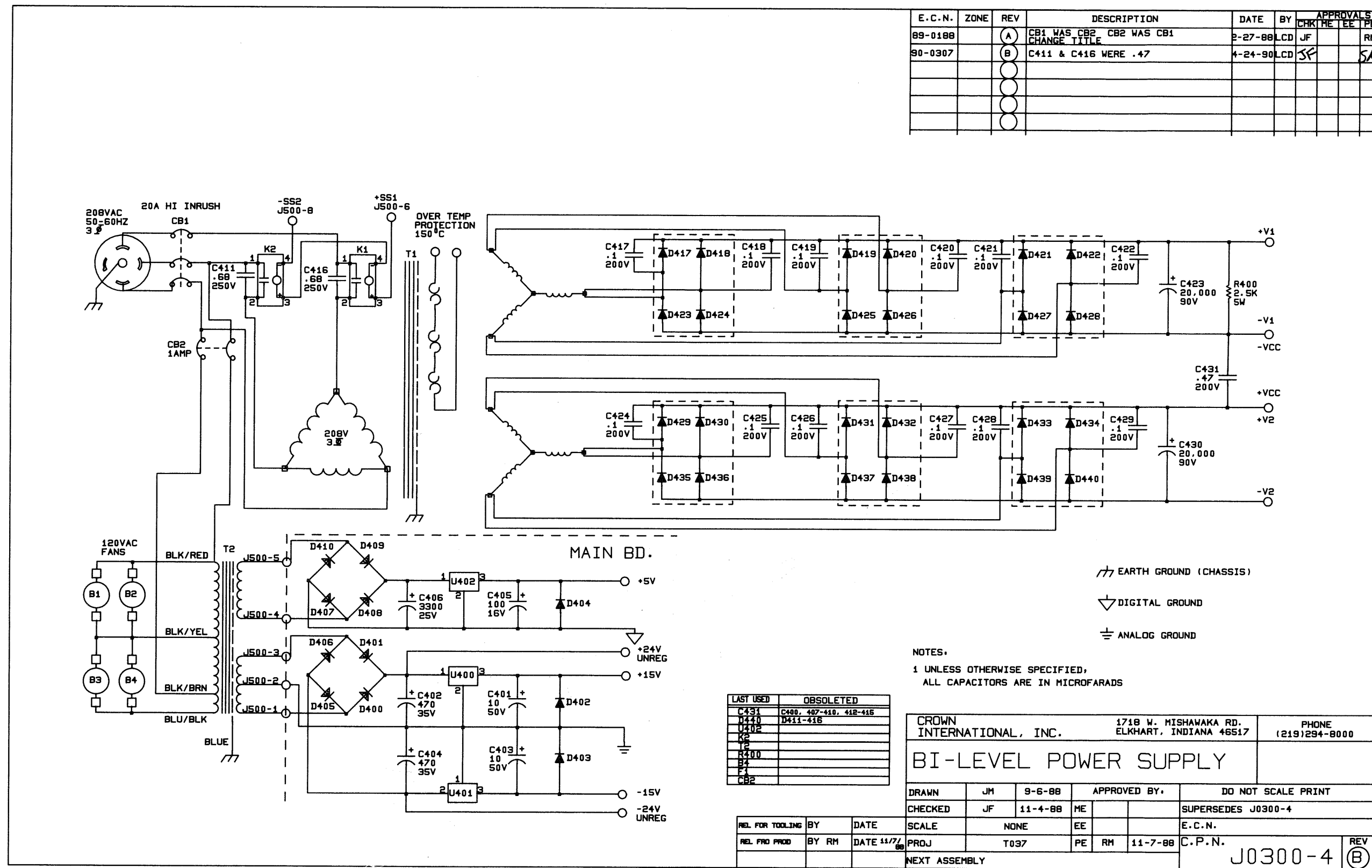

NOTES:
1 UNLESS OTHERWISE SPECIFIED,
ALL CAPACITORS ARE IN MICROFARADS

LAST USED	OBSOLETE
C431	C400, 407-410, 412-415
D440	D411-415
U402	
K2	
F1	
R400	
B4	
F1	
CB2	

CROWN INTERNATIONAL, INC. 1718 W. HISHAWAKA RD. ELKHART, INDIANA 46517 PHONE (219)294-8000

BI-LEVEL POWER SUPPLY

DRAWN JM 9-6-88 APPROVED BY: DO NOT SCALE PRINT
CHECKED JF 11-4-88 ME SUPERSEDES J0300-4

REL FOR TOOLING	BY	DATE	SCALE	NONE	EE	E.C.N.
REL PRO PROD	BY RM	DATE 11/7/88	PROJ	T037	PE RM	11-7-88
NEXT ASSEMBLY						C.P.N.

J0300-4 (B) REV

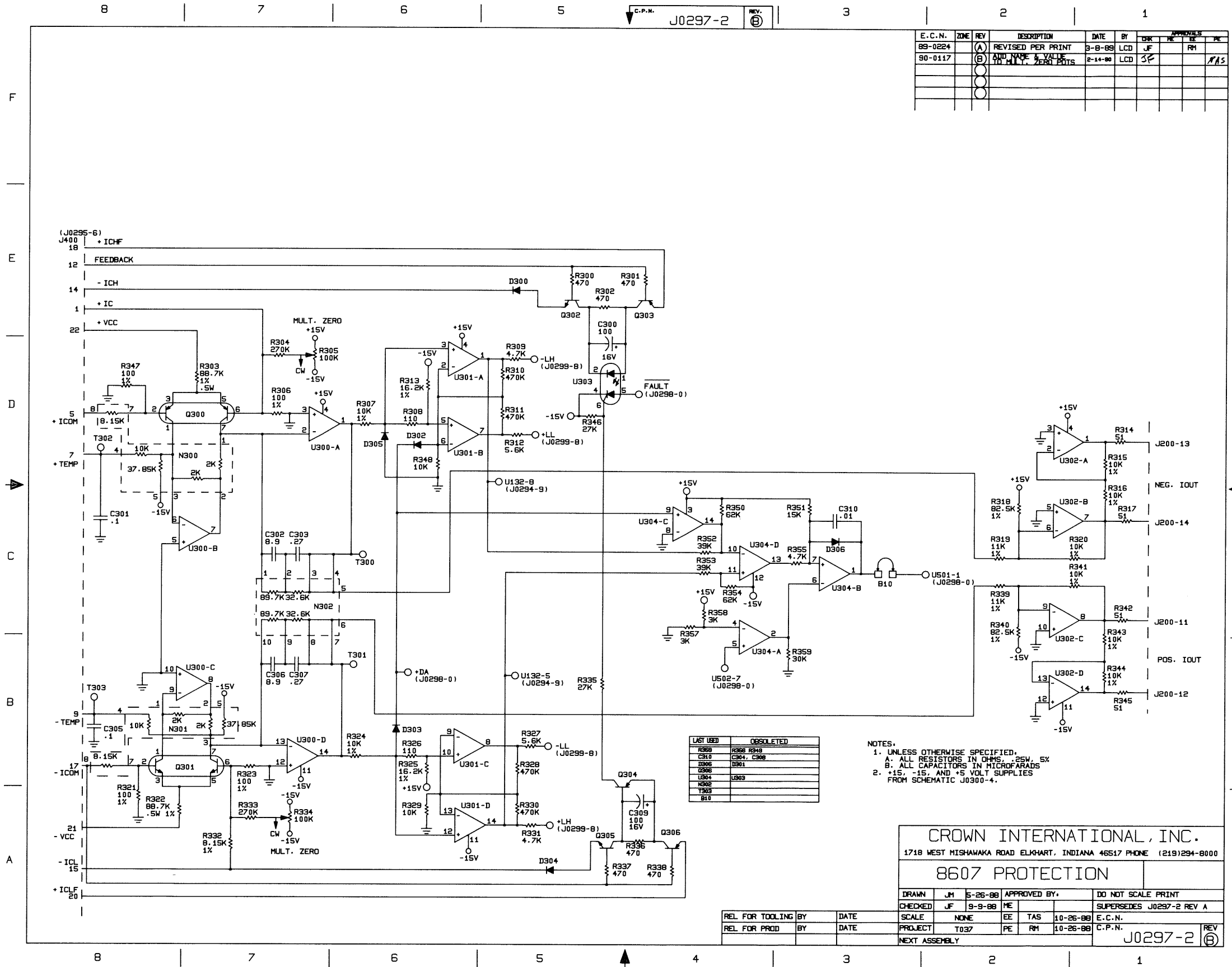

E.C.N.	ZONE	REV	DESCRIPTION	DATE	BY	CHK	APPROVALS
89-0224		(A)	REVISED PER PRINT	3-8-89	LCD	JF	PE
90-0117		(B)	ADD NAME & VALUE TO MULT. ZERO PPTS	2-14-89	LCD	SP	RM

LAST USED	OBSOLETE
R369	R368 R348
C310	C304, C306
D306	D301
Q305	
U304	U303
U302	
T303	
B10	

NOTES:
 1. UNLESS OTHERWISE SPECIFIED,
 A. ALL RESISTORS IN OHMS, .25W, 5%
 B. ALL CAPACITORS IN MICROFARADS
 2. +15V, -15V, AND +5V VOLT SUPPLIES FROM SCHEMATIC J0298-4.

CROWN INTERNATIONAL, INC.
 1718 WEST HISHAWAKA ROAD ELKHART, INDIANA 46517 PHONE (219)294-8000

8607 PROTECTION

DRAM	JM	5-26-88	APPROVED BY:	DO NOT SCALE PRINT
CHECKED	JF	9-9-88	ME	SUPERSEDES J0297-2 REV A
REL FOR TOOLING BY	DATE	SCALE	NONE	EE TAS 10-26-88 E.C.N.
REL FOR PROD BY	DATE	PROJECT	T037	PE RM 10-26-88 C.P.N.
NEXT ASSEMBLY				J0297-2 (B) REV

Schematic, 8607 Protection Circuit

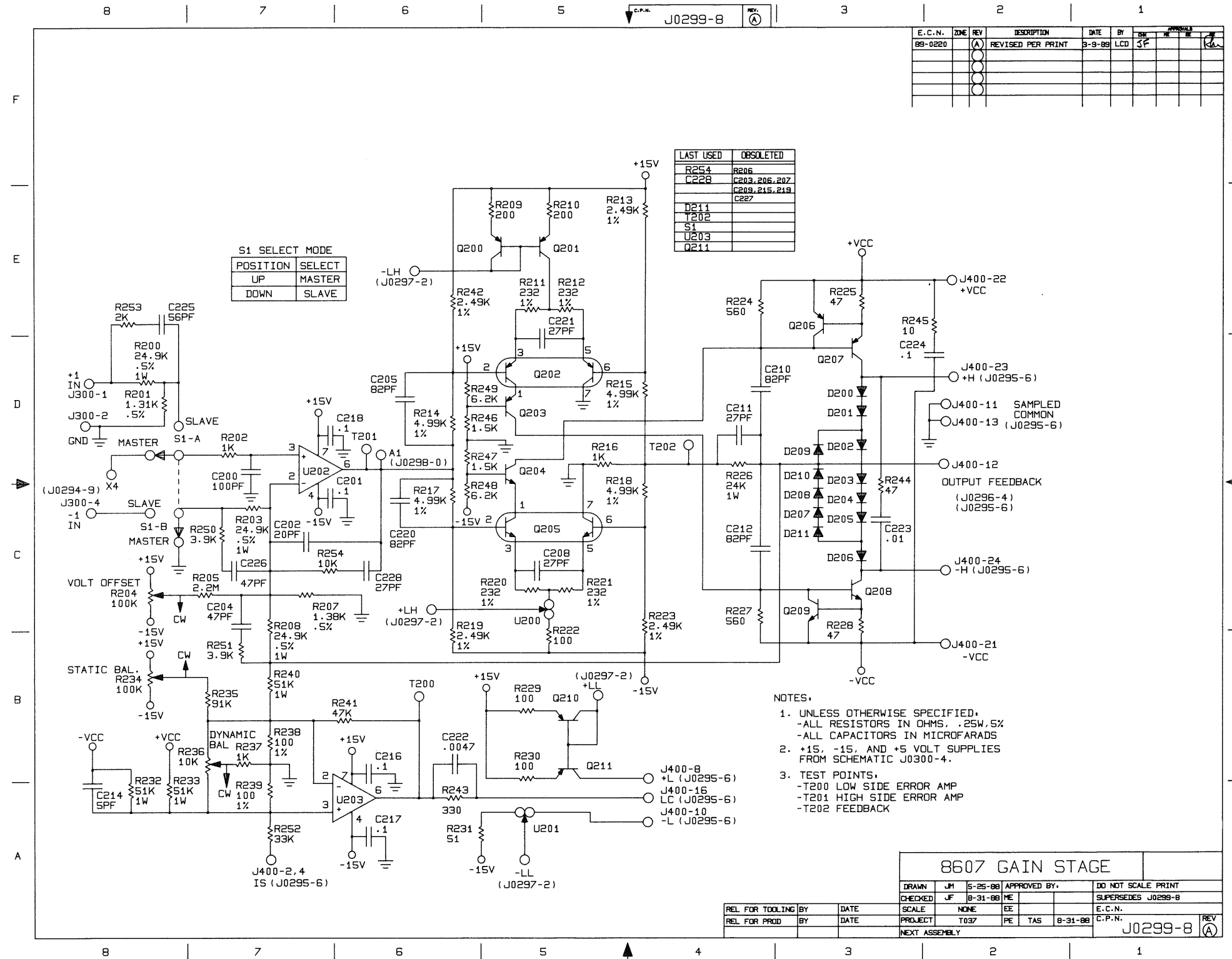

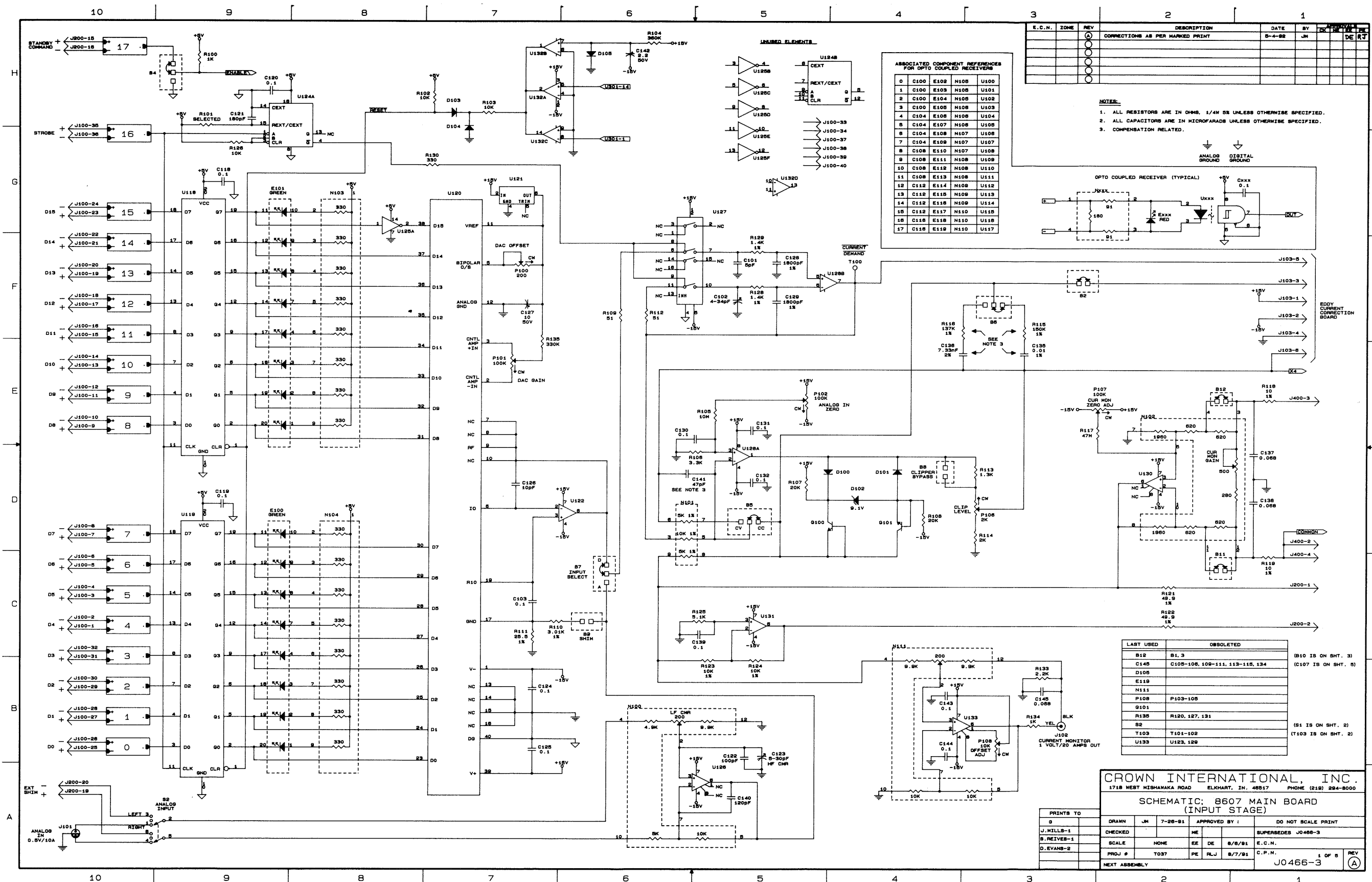

Schematic, 8607 Input Stage

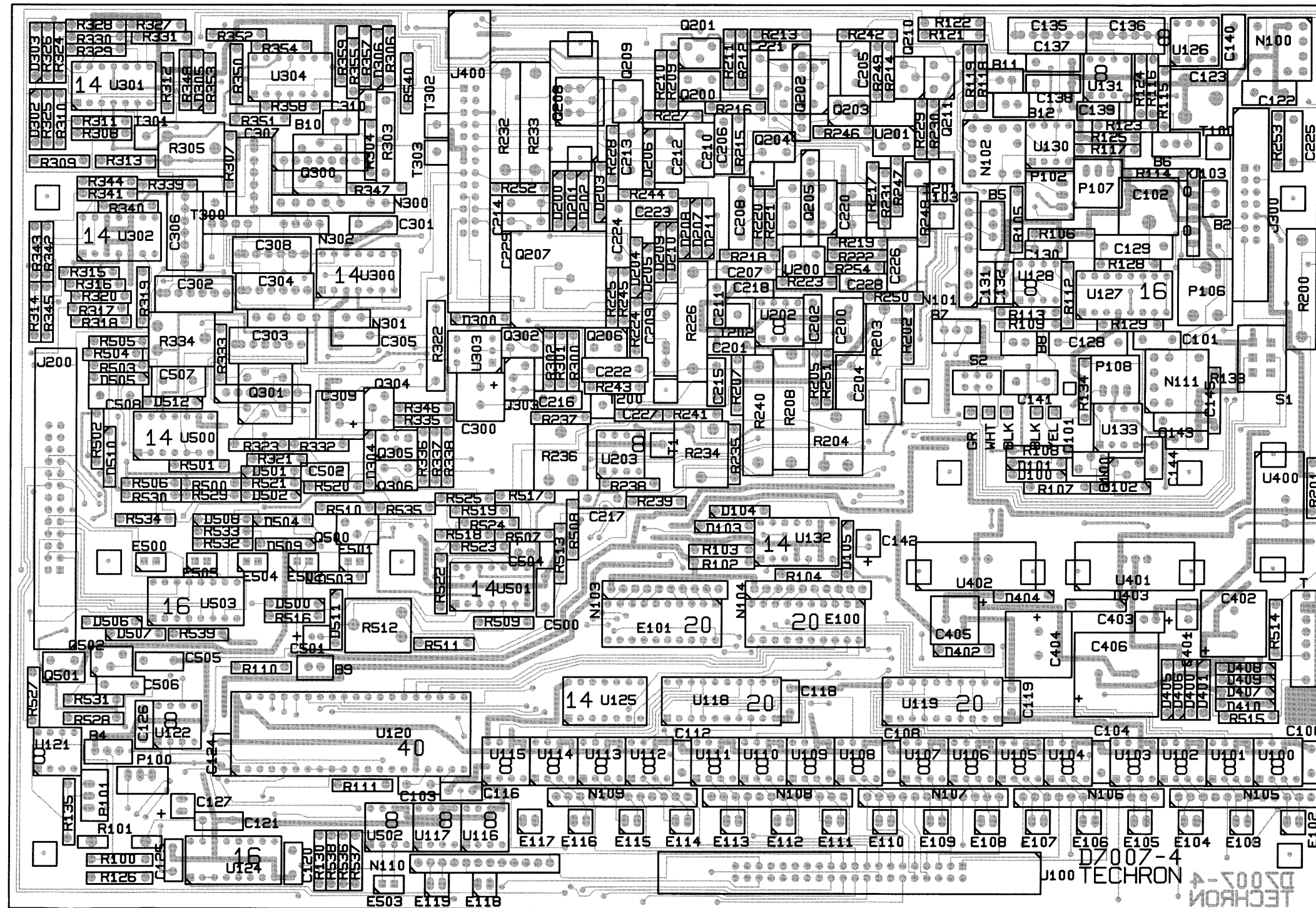

Illustration 7-12
8607 Main Circuit Board