

AETECHRON



8704

Operator's Manual

Wide-Bandwidth, High-Power Digital Amplifier

DECLARATION OF CONFORMITY

Issued By: AE Techron, Inc.
2507 Warren Street
Elkhart, IN 46516

For Compliance Questions Only: Larry Shank
+1 574-295-9495
lshank@aetechron.com

This Declaration of Conformity is issued under the sole responsibility of AE Techron, Inc., and belongs to the following product:

Equipment Type: Industrial Power Amplifiers

Model Name: 8704

EMC Standards:

- EN 61326-1: 2013 – Electrical Equipment for Measurement, Control and Laboratory Use – Industrial Level & Performance, Group 1, Class A, Criteria A
- CISPR 16-2-3 – Specification for radio disturbance and immunity measuring apparatus and methods – Part 2-3: Methods of measurement of disturbances and immunity – Radiated disturbance measurement
- CISPR 16-2-1 – Specification for radio disturbance and immunity measuring apparatus and methods – Part 2-1: Methods of measurement of disturbances and immunity – Conducted disturbance measurement
- EN 61000-4-11 – Electromagnetic compatibility (EMC) Part 4: Testing and measurement techniques – voltage dips, short interruptions and voltage variations immunity tests for equipment with input current up to 16A per phase
- EN 61000-4-8 – Electromagnetic compatibility (EMC) Part 4: Testing and measurement techniques – voltage dips, short interruptions and voltage variations immunity tests for equipment with input current up to 16A per phase
- EN 61000-4-6 – Electromagnetic compatibility (EMC) Part 4: Testing and measurement techniques – voltage dips, short interruptions and voltage variations immunity tests for equipment with input current up to 16A per phase
- EN 61000-4-5 – Electromagnetic compatibility (EMC) Part 4: Testing and measurement techniques – voltage dips, short interruptions and voltage variations immunity tests for equipment with input current up to 16A per phase
- EN 61000-4-4 – Electromagnetic compatibility (EMC) Part 4: Testing and measurement techniques – voltage dips, short interruptions and voltage variations immunity tests for equipment with input current up to 16A per phase
- EN 61000-4-3 – Electromagnetic compatibility (EMC) Part 4: Testing and measurement techniques – voltage dips, short interruptions and voltage variations immunity tests for equipment with input current up to 16A per phase
- EN 61000-4-2 – Electromagnetic compatibility (EMC) Part 4: Testing and measurement techniques – voltage dips, short interruptions and voltage variations immunity tests for equipment with input current up to 16A per phase

Safety Standard:

- EN 61010-1:2010/A1:2019 – Safety requirements for electrical equipment for measurement, control, and laboratory use

I certify that the product identified above conforms to the requirements of the EMC Council Directive 2014/30/EU, and the Low Voltage Directive 2014/35/EU.

Signed:



Larry J. Shank
President

Place of Issue: Elkhart, IN, USA
Date of Issue: 05-06-2022

CE Affixing Date: 05-04-2022

Three-Year, No-Fault Warranty

SUMMARY OF WARRANTY

AE TECHRON INC., of Elkhart, Indiana (Warrantor) warrants to you, the ORIGINAL COMMERCIAL PURCHASER and ANY SUBSEQUENT OWNER of each NEW **AE TECHRON INC. product, for a period of three (3) years from the date of purchase, by the original purchaser (warranty period) that the product is free of defects in materials and workmanship and will meet or exceed all advertised specifications for such a product. We further warrant the new AE Techron product regardless of the reason for failure, except as excluded in the Warranty.**

ITEMS EXCLUDED FROM WARRANTY

This AE Techron Warranty is in effect only for failure of a new AE Techron product which occurred within the Warranty Period. It does not cover any product which has been damaged because of any intentional misuse, or loss which is covered under any of your insurance contracts. This warranty does not extend to any product on which the serial number has been defaced, altered, or removed. It does not cover damage to loads or any other products or accessories resulting from **AE TECHRON INC.** product failure. It does not cover defects or damage caused by the use of unauthorized modifications, accessories, parts, or service.

WHAT WE WILL DO

We will remedy any defect, regardless of the reason for failure (except as excluded), by repair or replacement, at our sole discretion. Warranty work can only be performed at our authorized service centers or at our factory.

Expenses in remedying the defect will be borne by **AE TECHRON INC.**, including one-way surface freight shipping costs within the United States. (Purchaser must bear the expense of shipping the product between any foreign country and the port of entry in the United States and all taxes, duties, and other customs fees for such foreign shipments.)

HOW TO OBTAIN WARRANTY SERVICE

When you notify us or one of our authorized service centers of your need for warranty service, you will receive an authorization to return the product for service. All components must be shipped in a factory pack or equivalent which, if needed, may be obtained

from us for a nominal charge. We will take corrective actions and return the product to you within three weeks of the date of receipt of the defective product, or will make available to you a product of equal or better performance on temporary loan until your product can be repaired or replaced and returned to you. If the repairs made by us are not satisfactory, notify us immediately.

DISCLAIMER OF CONSEQUENTIAL AND INCIDENTAL DAMAGES

You are not entitled to recover from us any consequential or incidental damages resulting from any defect in our product. This includes any damage to another product or products resulting from such a defect.

WARRANTY ALTERATIONS

No person has the authority to enlarge, amend, or modify this warranty. The warranty is not extended by the length of time for which you are deprived of the use of this product. Repairs and replacement parts provided under the terms of this warranty shall carry only the unexpired portion of this warranty.

DESIGN CHANGES

We reserve the right to change the design of any product from time to time without notice and with no obligation to make corresponding changes in products previously manufactured.

LEGAL REMEDIES OF PURCHASER

There is no warranty that extends beyond the terms hereof. This written warranty is given in lieu of any oral or implied warranties not contained herein. We disclaim all implied warranties, including, without limitation, any warranties of merchantability or fitness for a particular purpose. No action to enforce this Warranty shall be commenced later than ninety (90) days after expiration of the warranty period. This statement of warranty supersedes any others contained in this manual for AE Techron products.

AE TECHRON INC.

Customer Service Department

2507 Warren St. Elkhart, IN, 46516, U.S.A.
(574) 295-9495
www.aetechron.com

Contents

1	Introduction	5
1.1	Features	5
1.2	Configuration Options.....	5
2	How to Use this Manual	6
2.1	Determine Your Amplifier Version.....	6
2.2	Safety First.....	6
3	Amplifier Unpacking and Installation	7
3.1	Unpacking	7
3.2	Installation	7
4	Connections and Startup	8
4.1	Connecting the Load	8
4.2	Connecting the Input Signal	8
4.3	Other DIP Switch Settings.....	9
4.4	Monitor and Sense Ports.....	9
4.5	Connecting the AC Supply	9
5	Amplifier Operation	11
5.1	Front-Panel Controls and Indicators.....	11
5.2	Back-Panel Controls & Connectors.....	13
6	Advanced Configuration.....	14
6.1	DIP Switch Configurations.....	15
6.2	Custom Compensation.....	17
7	Applications.....	18
7.1	Emergency Standby Switch or Safety Interlock	18
7.2	Controlled-Voltage vs. Controlled-Current Modes of Operation.....	18
7.3	Driving Reactive Loads	21
7.4	8704 Multi-amp Systems.....	21
8	Maintenance	31
8.1	Clean Amplifier Filter and Grills.....	31
9	Troubleshooting	32
9.1	Introduction & Precautions	32
9.2	No Signal.....	32
9.3	No LEDs Illuminated.....	32
9.4	Over/Under Line LED Lit	32
9.5	Run/Standby LED Remains Amber	32
9.6	Amplifier Overheats (Over Temp Fault Condition).....	32
9.7	Fault LED is Illuminated	33
9.8	Factory Service	33



Figure 1.1 – 8704 Front Panel

1 Introduction

Congratulations on your purchase of the 8704 digital power amplifier. 8704 amplifiers are 400Vp, low-noise, DC-to-250-kHz switch -mode amplifiers. They are fast enough for DC automotive dropout testing and capable of AC voltages required for ISO 61000 and Aviation testing. Plus, they have low enough noise and distortion specifications to be the reference power source in power quality measurements.

1.1 Features

Wide Bandwidth and Flexible

The 8704 amplifier is capable of reproducing AC, DC and AC+DC waveforms into loads from a dead short to high impedance. It can be used to simulate a battery at 13.5 VDC or be an AC source with a L-N potential of up to 250 VAC. Rated current, for a given voltage, is available for all waveform types (AC, DC or AC+DC) at frequencies from DC to 250 kHz. Voltages from 0 to 250 VRMS are available with no changes in configuration.

Reuses Energy from Reactive Loads

The 8704 excels when it comes to driving reactive loads. As frequencies increase, the effective-impedance of the load becomes a much larger part of the total load to be driven (especially with inductive loads like coils).

However, when driving reactive loads, the 8704 is capable of receiving, reprocessing and returning to the load up to 4X its rated power. The result is a bench top system capable of 16 kVA+ output while drawing less than 4 kW of AC mains power!

Performance Overview	
Bandwidth	DC - 250 kHz
Voltage	0 to 250 V _{RMS} ; 0 to 350 VDC
Current	60 A _{RMS}
Distortion	<0.2%
Power	4 kW
Apparent Power	16 kVA

1.2 Configuration Options

A key to everyday product usability is quick and easy product (re)configuration. The 8704 provides all key configuration controls on either the front or back panels of the unit. Configuration options available include:

- **Gain:** Fixed or variable gain (0 to 40)
- **Current Limit:** From 5% to rated limit (to protect fragile DUTs or where specified in the Standard)
- **DC Control:** DC enabled or DC blocked and DC Servo (for driving transformer-coupled loads, coils)
- **Input:** Balanced and/or unbalanced
- **Mode:** Voltage source or current source
- **Output Impedance:** Variable from 0 to 1 ohm (Voltage mode)

2 How to Use this Manual

2.1 Determine Your Amplifier Version

This manual contains setup and operating information for two versions of the 8704 amplifier: Versions 2 and 3. These amplifiers have a serial number ending in 0004 and higher.

Version 2 8704 amplifiers have a remote sense port on the amplifier back panel. **Version 3** 8704 amplifiers do not have the remote sense on the back panel.

See **Figure 2.1** for assistance in identifying the version of the amplifier you are using.

Throughout the manual, instructions given will apply to both versions unless otherwise indicated. Please refer to the instructions applicable to your amplifier version, where indicated.

2.2 Safety First

Throughout this manual special emphasis is placed on good safety practices. The following graphics are used to highlight certain topics that require extra precaution.

WARNING

WARNING alerts you to hazards that could result in severe injury or death. Note the explanation of the hazard and the instructions for avoiding it.

CAUTION

CAUTION indicates hazards that could result in potential injury or equipment or property damage. Once again, note the explanation of the hazard and the instructions for avoiding it.

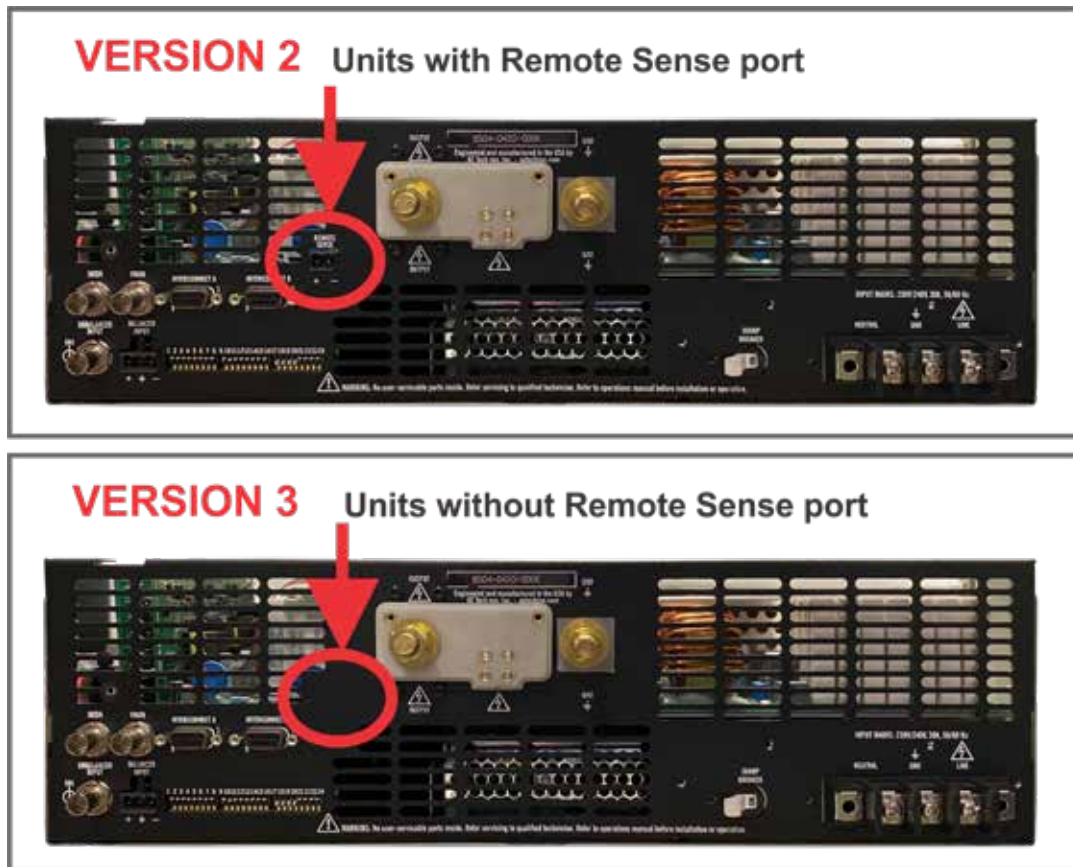

Figure 2.1 – Identifying 8704 Versions



Figure 3.1 – 8704 Back Panel

3 Amplifier Unpacking and Installation

The 8704 amplifier is a precision instrument that can be dangerous if not handled properly. Lethal voltages are present in both the AC input supply and the output of the amplifier. For this reason, safety should be your primary concern when you setup and operate this amplifier.

3.1 Unpacking

All amplifiers are tested and inspected for damage before leaving the factory. Carefully unpack and inspect the amplifier for damage. **Please note any damage for future reference and notify the shipping company immediately if damage is found.** Also, please save the shipping carton and materials as evidence of damage and/or for returning the amplifier for repair.

3.2 Installation

The 8704 amplifiers are packaged in a rugged powder-coated chassis. This chassis is 3U (rack units) tall, and has rack “ears” on each side of the front panel for mounting to a standard EIA (Electronic Industries Association) rack. Use standard

rack mounting hardware to mount the amplifier. Use nylon washers if you wish to protect the powder-coat finish on the front of the amplifier.

Optionally, the amplifier can be placed on a bench top; please keep in mind that the protective powder-coating can be scratched when placed on other equipment or on a bench top, especially when there is dirt present. To protect the finish, a set of rubber feet is included in the toolkit that can be installed on the bottom of the amplifier.

Allow ample space on the sides and especially the back of the amplifier for heated air to escape. The amplifier should be mounted in a rack that is adequately ventilated and not sealed. Likewise, the front of the amplifier should be unobstructed to allow cool air to enter the amplifier.

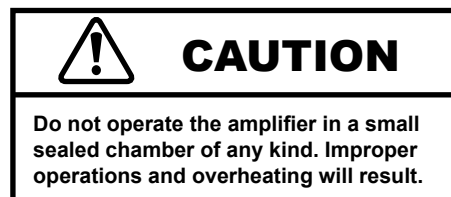

4 Connections and Startup

This section details the wiring and startup procedures for an 8704 amplifier operating in Controlled-Voltage mode (factory default). Before connecting the amplifier inputs and outputs, make sure the AC power cord is unplugged.

Testing Before Controlled-Current Operation

IMPORTANT: If your application requires Controlled Current operation, the 8704 amplifier first should be wired and tested in Controlled-Voltage mode to verify that the amplifier and input signal are operating correctly. Once proper operation is confirmed, refer to the **Applications** section of this manual for instructions on configuring and operating your amplifier in Controlled-Current mode.

4.1 Connecting the Load

4.1.1 Preparation and Cautions

Before connecting the amplifier, make sure the AC power is disconnected.

Always use the appropriate wire size and insulation for the maximum current and voltage expected at the output. Never connect the output of the amplifier to any other model amplifier, power supply, signal source, or other inappropriate load; fire can result.

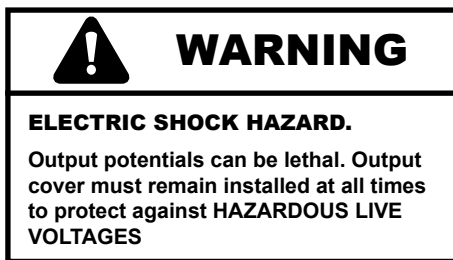

4.1.2 Output Connections

Connection to the output of the amplifier is to a pair of high-current output terminals. Wires terminated with 3/8-inch ring terminals are recommended when connecting to the output terminals. Connect the load across the terminals marked "OUTPUT" (positive) and "GND" (ground). The GND terminal also can be connected to an external ground point such as the rack chassis, if desired. See **Figure 4.2**.

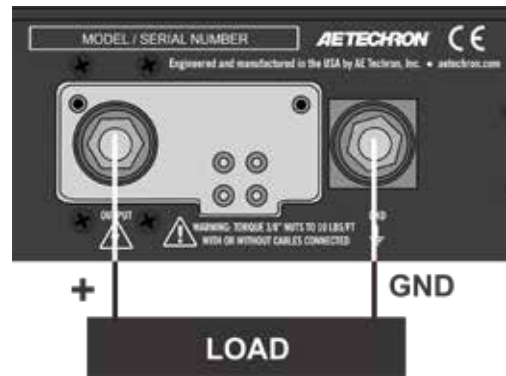

Figure 4.2 – Connecting the Load

Be sure to install the output safety cover after wiring the output connections. See **Figure 4.3**.



Figure 4.3 – Output Safety Cover

4.2 Connecting the Input Signal

Both an unbalanced Input BNC jack and a balanced Input "WECO" terminal block connector are provided on the amplifier back panel for signal input. Connect your input signal source to the unbalanced or balanced input connector as shown in **Figure 4.4**. Use cables that are high quality and shielded to minimize noise and to guard against possible feedback.

The back-panel DIP switch #1 can be used to enable/disable the unbalanced input connector, and DIP switch #2 can be used to enable/disable the balanced input connector.

When these two DIP switches are placed in the UP position (factory default), the input connectors are enabled. When the DIP switches are placed in the DOWN position, the input connectors are disabled. See **Figure 4.5** for DIP switch locations.

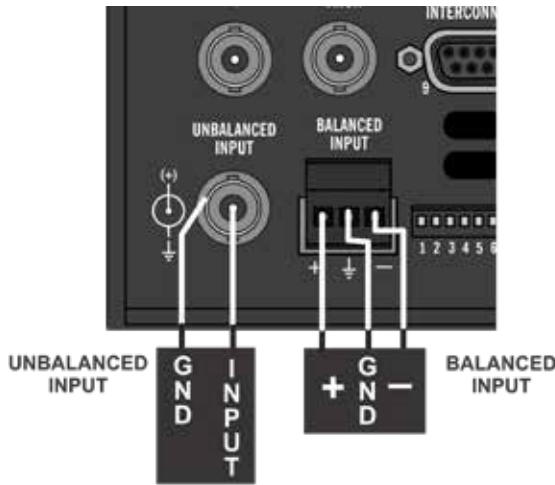

Figure 4.4 – Wiring for Unbalanced or Balanced Input Connector

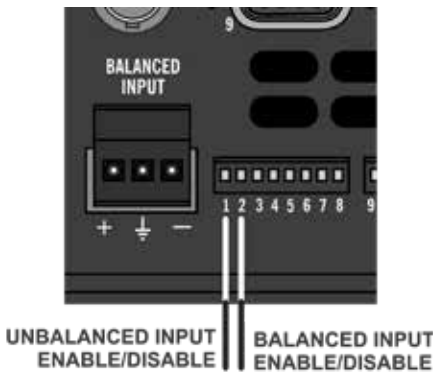

Figure 4.5 – DIP Switch Locations for Input Connectors Enable/Disable

4.3 Other DIP Switch Settings

Other DIP switches can be used to enable features or configure the amplifier for special applications. See the **Advanced Configuration** section of this manual for more information. Before operating the amplifier, check to make sure all DIP switches are set as intended.

4.4 Monitor and Sense Ports

The amplifier provides four additional back-panel ports (five on Version 2 models):

- Current Monitor (BNC connector)
- Voltage Monitor (BNC connector)
- Multi-amp Connectors (9-pin dSub connectors, two total)

- **Version 2 models only:** Remote Sense Port (2-pin terminal block connector).

See the **Applications** section of this manual for information on using these ports

4.5 Connecting the AC Supply

4.5.1 Disconnect and Inlet Wiring Protection

A safety disconnect device for the AC mains input must be installed so that it is both nearby and accessible to the operator. The disconnect must be clearly labeled.

Inlet wiring must support the rated current.

The amplifier must be protected by fuses or circuit breakers that protect the power inlet wiring with a maximum rating of no more than 30A.

	WARNING
<p>The risk of lethal ELECTRICAL SHOCK exists when connecting AC mains! Disconnect the source before connecting AC power wires to the amplifier's AC inputs.</p>	

4.5.2 AC Inlet Connections

Always operate the amplifier from the proper AC mains. The 8704 amplifier requires single-phase, 50-60 Hz, 208 VAC, or 230/240 VAC at 30A with no more than $\pm 10\%$ variance above or below the line voltage. The amplifier will not operate properly outside these limits.

Connect protective grounding terminal to AC mains ground before turning on power to prevent electric shock hazard.

Do not disconnect or disable the protective grounding connection. Doing so causes a potential electrical shock hazard.

Connect the AC supply to the three-terminal barrier strip located on the amplifier back panel (see **Figure 4.6 and 4.7**).

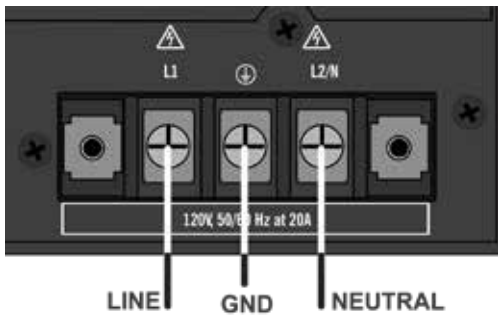

Figure 4.6 – AC Mains Barrier Strip Wiring for 230/240VAC models

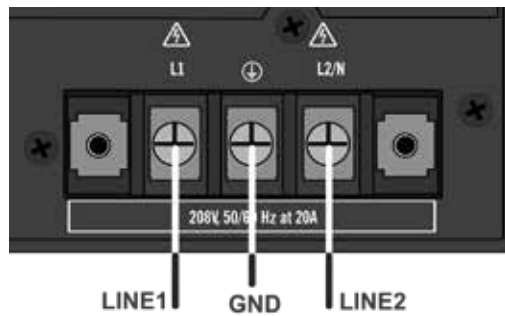



Figure 4.7 – AC Mains Barrier Strip Wiring for 208VAC models



Figure 4.8 – AC Inlet Safety Cover

Install AC inlet cover prior to connecting to the supply source. See **Figure 4.8**.

	<h2>WARNING</h2>
<p>ELECTRIC SHOCK HAZARD.</p> <p>AC supply potentials can be lethal. Inlet cover must remain installed at all times to protect against HAZARDOUS LIVE VOLTAGES</p>	

Start-up Procedure

1. Turn down the level of your signal source.
2. Place the back-panel breaker switch in the ON position.
3. Press the front-panel Standby-Run switch to the Run position to energize the amplifier.
4. Wait until the Run/Standby indicator turns solid green.
5. Adjust your input signal level to achieve the desired output level.

WARNING: If amplifier has been unused/inactive for 2 years or more, please startup connected to a low-voltage DC power supply. Start at 10% of the rated voltage and gradually increase to avoid damaging internal components.

5 Amplifier Operation

5.1 Front-Panel Controls and Indicators

This section provides an overview of Front-Panel controls and indicators found on the 8704. Refer to **Figure 5.1** for component locations.

5.1.1 Standby-Run Switch

The Standby-Run switch controls the power to the amplifier's high-voltage transformers. **Switch to the Run position (right) to energize the amplifier. Switch to the Standby position (left) to remove power from the high-voltage transformers and place the amplifier in Standby mode.**

5.1.2 Run/Standby Indicator

Run mode: The indicator will be lit solid green. The amplifier's high-voltage transformers are energized and the unit will amplify the input signal.

Standby mode: The indicator will be lit solid amber. The amplifier will be placed in Standby when one of the following conditions occurs:

1. High/Low Line error
2. Overtemp condition
3. Fault condition
4. The user sets the front-panel Standby-Run switch to the Standby (left) position.

In Standby mode, the amplifier's low-voltage transformer is energized but the high-voltage transformers are not.

To release the amplifier from Standby mode:

1. **High/Low Line error:** Clear the over- or under-voltage condition. The amplifier will resume operation when the input voltage is brought within the operating range of the amplifier.
2. **Overtemp condition:** Remove the input signal from the amplifier and leave the amplifier with the Standby-Run switch in the Run position and with the fans operating to cool the amplifier. When the amplifier's internal temperature drops to less than 100°C, the amplifier will resume operation.
3. **Fault condition:** Turn the front-panel Standby-Run switch to Standby and then back to Run to reset the amplifier. If the fault condition recurs or does not clear, the amplifier may require servicing. See the **Troubleshooting** section for more information.
4. **Standby-Run switch pressed:** When the amplifier is operating (Run mode), setting the front-panel Standby-Run switch to the Standby position (left) will place the amplifier in Standby mode. Set the switch to Run (right) to release the amplifier from Standby and return the amplifier to Run mode.

5.1.3 Signal/Overload Indicator

Signal Presence: When an input signal is presented at an active signal input on the amplifier at a level greater than 0.5V, the Signal/Overload indicator will light solid green.

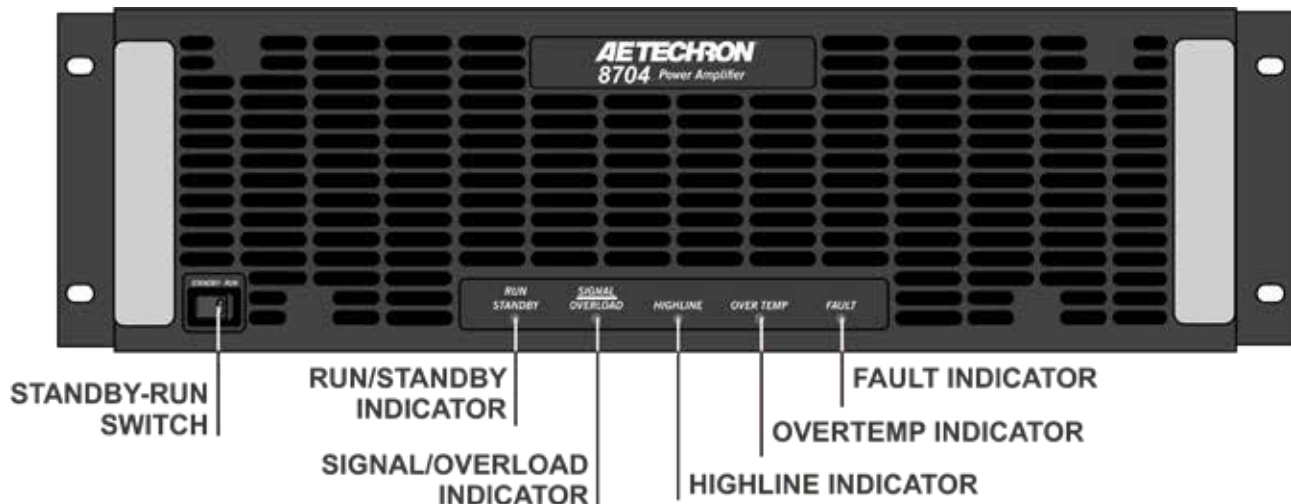

Figure 5.1 – Front Panel Controls and Indicators

Overload (clipping): The indicator will flash amber intermittently. When the indicator flashes amber, this indicates that the output of the system could not follow the input signal due to voltage or current limits. The amber Overload indicator will begin flashing when distortion is greater than 0.1%.

5.1.4 High/Low Line Indicator

This amber indicator will illuminate, and the amplifier will be placed in Standby if the detected AC mains voltage is outside of the operable range of the amplifier ($\pm 10\%$). This can occur if the amplifier's back-panel breaker is not in the on position (left), or if the AC supply into the amplifier is higher or lower than the operable range.

To remove the amplifier from Standby, the AC mains must be brought to within the optimal range. Once the fault condition has been cleared, the amplifier will return automatically to Run mode. If the High/Low Line indicator does not turn off or if the amplifier does not return from Standby, the amplifier may require servicing. See the **Troubleshooting** section for more information.

5.1.5 Overtemp Indicator

The amplifier monitors the temperature inside the high-voltage transformers and in the output stage heat sinks. The amber Overtemp indicator will light and the amplifier will be placed in Standby mode

when the temperature sensors detect a condition that would damage the amplifier. If the Overtemp pulse is extremely short, as in the case of defective wiring or switches, this indicator may be lit too briefly to observe.

To remove the amplifier from Standby and return it to normal operation after an Overtemp fault has occurred, make sure the Standby-Run switch is in the Run position and the amplifier fans are running, and then remove the input signal from the amplifier. Allow the fans to run until the amplifier automatically returns to Run mode. See the **Troubleshooting** section for information on identifying and correcting the cause of an Overtemp fault condition.

5.1.6 Fault Indicator

The red Fault indicator will light and the amplifier will be placed in Standby under two conditions:

1. High frequency oscillation is causing high shoot-through current.
2. An output transistor has shorted, causing the output fault condition.

Cycle the front-panel Standby-Run switch (Standby, then Run) to reset the amplifier. If the fault condition recurs or does not clear, the amplifier may require servicing. See the **Troubleshooting** section for more information.

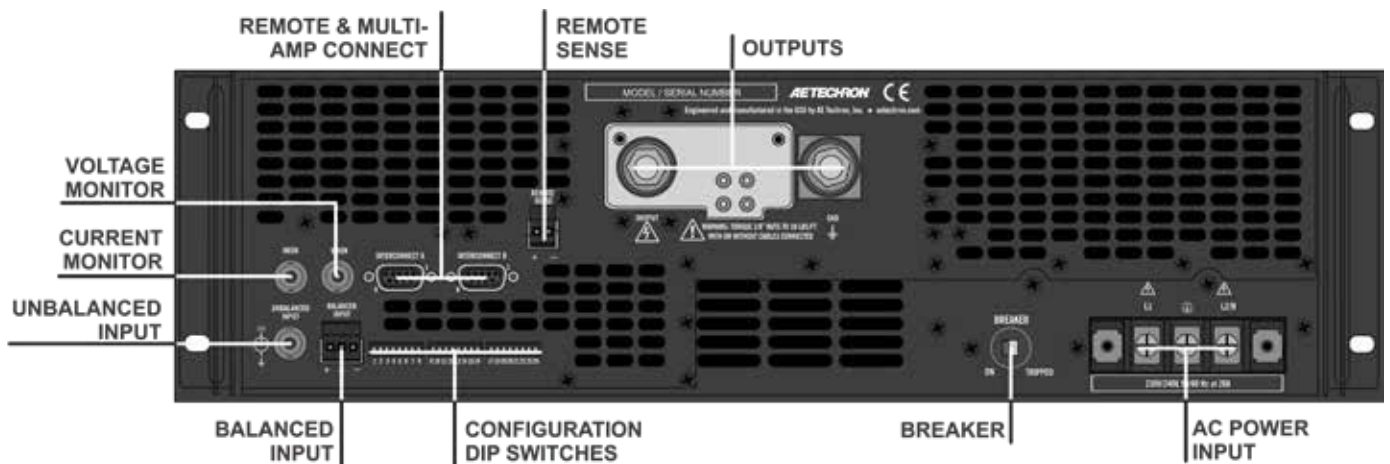

Figure 5.2 – Back Panel Controls and Connectors

5.2 Back-Panel Controls & Connectors

This section provides an overview of Back-Panel controls and connectors found on the 8704. Please refer to **Figure 5.2** for component locations.

AC Power Input – Three-terminal barrier strip connector.

Breaker– Protects the amplifier from voltage surge on the AC power input.

Output Terminals – Connect output lines from the load to this pair of high-current output terminals using 3/8-inch ring terminals.

Unbalanced BNC Input Connector – This input option provides a standard unbalanced input.

Balanced WECO Input Connector – This input option provides a balanced input.

DIP Switches – This bank of 24 DIP switches provides various functions and allows the amplifier to be configured for special applications. See the **“Advanced Configuration”** section for more information.

Current Monitor Connector – This unbalanced BNC port allows for connection to current monitoring equipment. The current monitor output is 1V = 20A.

Voltage Monitor Connector – This unbalanced BNC port allows for connection to voltage monitoring equipment. The voltage monitor output is 1V = 40V.

Multi-amp Connectors – These two 9-pin D-sub connectors, labeled Interconnect A and Interconnect B, can be used to connect two 8704 amplifiers in a Parallel or Push/Pull configuration. They can also be used to set up a Safety Interlock circuit to automatically place the amplifier in Standby mode when tripped. See the **“Applications”** section for more information.

Remote Sense Port (Version 2 units only) – This 2-pin terminal block connector provides a sense line for voltage correction. The Remote Sense port can be useful when the voltage at the load must be precise. If the cables connecting the amplifier and the load are very long or under-sized, the voltage drop between the amplifier and load can be corrected.

Connect to the Remote Sense Port using high-quality shielded wire and the supplied terminal block connector. Connect the shield to a 1/4-inch ring terminal, then secure to the grounding screw located next to the terminal block connector. See **Figures 5.3 and 5.4**.

The benefits of this feature are limited to frequencies below 10 kHz.

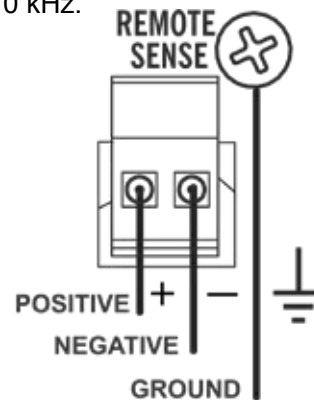

Figure 5.3 – Remote Sense Port Wiring



Figure 5.4 – Connected Remote Sense Port

6 Advanced Configuration

The 8704 amplifier was designed to offer exceptional versatility in operation. You can choose from a range of field-configurable options, including:

- Enable the unbalanced or balanced signal input connections, or use both inputs.
- Select DC-coupled or AC-coupled operation.
- Enable DC Servo to ensure DC offset remains at zero and safely drive coils and transformers.
- Select Controlled-Current or Controlled-Voltage modes of operation.
- Select between two compensation networks for Controlled Current operation: CC1, designed for loads from 50 μ H to 500 μ H; or CC2, designed for loads from 500 μ H to 1.5 mH.
- Limit current output via programmable current limits.
- Adjust the amplifier gain from 0.16 to 40 in increments of 0.16.
- Configure two 8704 amplifiers for operation as a Push/Pull (series) or Parallel system.
- Enable electronic gain matching to optimize parallel operation of two 8704 amplifiers.
- Select and enable a synthetic impedance from 0.125 ohms to 0.875 ohms.

8704 Default DIP Switch Settings

Red = Default

DIP SWITCH SETTINGS		UP	DOWN
1	UNBALANCED INPUT	ON	OFF
2	BALANCED INPUT	ON	OFF
3	DC SERVO	ON	OFF
4	OPERATION MODE	CV	CC
5	COMPENSATION NETWORK 2	ON	OFF
6	COMPENSATION NETWORK 1	ON	OFF
7	CONTROL CONFIGURATION	MASTER	FOLLOWER
8	COUPLING	DC	AC
9	GAIN BIT 8 (MSB)	20	OFF
10	GAIN BIT 7	10	OFF
11	GAIN BIT 6	5	OFF
12	GAIN BIT 5	2.5	OFF
13	GAIN BIT 4	1.25	OFF
14	GAIN BIT 3	0.63	OFF
15	GAIN BIT 2	0.31	OFF
16	GAIN BIT 1 (LSB)	0.16	OFF
17	ELECTRONIC GAIN MATCHING	ON	OFF
18	SYNTHETIC IMPEDANCE BIT 3 (MSB)	0.5 Ω	OFF
19	SYNTHETIC IMPEDANCE BIT 2	0.25 Ω	OFF
20	SYNTHETIC IMPEDANCE BIT 1 (LSB)	0.125 Ω	OFF
21	CURRENT LIMIT BIT 4 (MSB)	+80A	OFF
22	CURRENT LIMIT BIT 3	+40A	OFF
23	CURRENT LIMIT BIT 2	+20A	OFF
24	CURRENT LIMIT BIT 1 (LSB)	+10A	OFF

NOTE: ALL BIT SWITCHES ARE ADDITIVE. UP = ON.

Figure 6.1 – Default DIP Switch Settings and Descriptions

6.1 DIP Switch Configurations

The 8704 amplifier provides 24 DIP switches located on the amplifier back panel. Most configuration settings can be made using these DIP switches. See **Figure 6.1** for default DIP switch settings and descriptions.

SW#1: Unbalanced Input

When this switch is in the UP position (default), the unbalanced BNC input connector is enabled and can be used to send an input signal to the amplifier. When this switch is in the DOWN position, this connector is disabled. Note that disabling an unused input connector can help to minimize noise going into the amplifier.

SW#2: Balanced Input

When this switch is in the UP position, the balanced WECO input connector is enabled and can be used to send an input signal to the amplifier. When this switch is in the DOWN position (default), this connector is disabled. Note that disabling an unused input connector can help to minimize noise going into the amplifier.

SW#3: DC Servo

The DC Servo function ensures that no DC offset is present at the signal output (-3 dB at 3 Hz). Select DC Servo when driving transformers or other coils. When the DC Servo DIP switch is in the UP position, the DC Servo function is enabled. When this switch is in the DOWN position (default), the DC Servo function is disabled.

	<h2>CAUTION</h2>
<p>Do not change the setting of the Operation Mode switch while the amplifier is operating (Run mode). Damage to the amplifier or the load can occur. Place the amplifier in Standby mode by pressing the front-panel Standby-Run switch before changing the Operation Mode setting.</p>	

SW#4: Operation Mode

When the Operation Mode DIP switch is in the UP position (default), the amplifier will operate in Controlled-Voltage mode, and the amplifier's output voltage will be controlled by its input voltage

	<h2>CAUTION</h2>
<p>In Controlled-Current Mode, the load is part of the amplifier circuit, and the relationship of the load to the amplifier is critical. For proper and safe operation in Controlled-Current mode, you must observe the following guidelines:</p> <ol style="list-style-type: none"> 1. Properly attach a load before operating the amplifier. 2. DO NOT use a blocking capacitor. The load must have a DC path. 3. Never leave the load open. If you feel the load must be fused, which could lead to a potential open circuit, please contact AE Techron Technical Support. 4. Check to make sure the load has some inductive component. 5. Provide appropriate Compensation for the load, using either Compensation Network 1 (SW#6) or Compensation Network 2 (SW#5). If neither compensation network is adequate for your load, contact AE Techron Technical Support. 6. Turn off the amplifier immediately if oscillation occurs. <p>Failure to follow these guidelines may result in damage to the amplifier or load.</p>	

signal. When this switch is in the DOWN position, the amplifier will operate in Controlled-Current mode, and the amplifier's output current will be controlled by its input voltage signal.

IMPORTANT: Controlled-Current operation requires the use of a compensation network. The 8704 amplifier provides two installed compensation networks: one suitable for loads from 50 μH to 500 μH ; the other suitable for loads from 500 μH to 1.5 mH. For more information on Controlled-Current operation, including instructions for selecting the best compensation option for your application, see the topic "Controlled Current Operation" in the Applications section of this manual. If neither of the available RC networks is suitable for your application, please contact **AE Techron Technical Support.**

SW#5: Compensation Network 2

When the 8704 amplifier is used in Controlled-Current mode, the current control loop is tuned with an RC network. The factory default network (Compensation Network 1) provides 100k ohm resistance and 2.2 nF capacitance and should be used with loads that are 50 μH to 500 μH . If this default network is not adequate for your applica-

tion and load, the Compensation Network 1 switch can be turned off and the Compensation Network 2 switch can be used to enable a network that provides 100k ohm resistance and 10 nF capacitance and should be used with loads that are 500 μ H to 1.5 mH.

NOTE: It is recommended to only use one of the compensation networks at a time. Having SW#5 and SW#6 both on (UP) will likely provide improper compensation for the load, and may result in amplifier instability.

For more information on Controlled-Current operation, including instructions for selecting the best compensation setting for your application, see the topic “Controlled Current Operation” in the Applications section of this manual. If neither of the available RC networks is suitable for your application, please contact **AE Techron Technical Support**.

SW#6: Compensation Network 1

When the 8704 amplifier is used in Controlled-Current mode, the current control loop is tuned with an RC network. The Compensation Network 1 switch enables the factory default RC network. This provides 100k ohm resistance and 2.2 nF capacitance and should be used with loads that are 50 μ H to 500 μ H. If this default network is not adequate for your application and load, the Compensation Network 1 switch can be turned off and the Compensation Network 2 switch can be used to enable a network that provides 100k ohm resistance and 10 nF capacitance and should be used with loads that are 500 μ H to 1.5 mH.

NOTE: It is recommended to only use one of the compensation networks at a time. Having SW#5 and SW#6 both on (UP) will likely provide improper compensation for the load, and may result in amplifier instability.

For more information on Controlled-Current operation, including instructions for selecting the best compensation option for your application, see the topic “Controlled Current Operation” in the Applications section of this manual. If neither of the available RC networks is suitable for your application,

please contact **AE Techron Technical Support**.

SW#7: Control Configuration

When this switch is in the UP position (default), the amplifier will function as a stand-alone amplifier or as a Master amplifier in a multi-amp system. When this switch is in the DOWN position, the amplifier will function as a Follower amplifier in a multi-amp system.

For more information on multi-amplifier system configuration and operation, see the **Applications** section.

SW#8: Coupling

When the Coupling DIP switch is in the UP position (default), the amplifier can receive and amplify both DC and AC signal. When this switch is in the DOWN position, a 30-Hz high-pass filter on the inputs prevents the transmission of DC signal.

SW#9 – SW#16: Gain

The amplifier gain can be adjusted from 0.16 to 40 in increments of 0.16 using switches 9 through 16. All switches are additive and provide the following values toward the total Gain amount.

SW#9 = 20.00	SW#13 = 1.25
SW#10 = 10.00	SW#14 = 0.63
SW#11 = 5.00	SW#15 = 0.31
SW#12 = 2.50	SW#16 = 0.16

Refer to the chart in **Appendix A** to quickly determine the switch settings for your desired amplifier gain.

SW#17: Electronic Gain Matching

The Electronic Gain Matching function serves to minimize circulating currents when multiple amplifiers are used in a parallel configuration. When enabled, the Electronic Gain Matching function progressively increases impedance from the voltage gain as current increases, up to a maximum 0.20-ohm increase. This allows the amplifiers to operate in parallel without the use of separate ballast resistors. For more information on multi-amplifier system configuration and operation, see the **Applications** section.

When the Electronic Gain Matching DIP switch is in the DOWN position (default), the function is dis-

ON = DIP Switch UP OFF = DIP Switch DOWN			
SW#18	SW#19	SW#20	Synthetic Impedance
ON	ON	ON	0.875Ω
ON	ON	OFF	0.750Ω
ON	OFF	ON	0.625Ω
ON	OFF	OFF	0.500Ω
OFF	ON	ON	0.375Ω
OFF	ON	OFF	0.250Ω
OFF	OFF	ON	0.125Ω
OFF	OFF	OFF	0.00Ω

Figure 6.2 – Synthetic Impedance Switch Configurations

abled. When this switch is in the UP position, Gain Matching is enabled.

SW#18 - SW#20: Synthetic Impedance

These three switches allow the addition of a synthetic impedance on the output of the amplifier. Synthetic Impedance can be used to increase stability when driving capacitive loads. It can also be used in testing where the effect of long power lines needs to be simulated (such as for power utility applications).

When all four switches are in the DOWN position (default), Synthetic Impedance is disabled. The synthetic impedance can be added in increments of 0.125 ohms by setting one or more of the synthetic impedance switches in the UP position. Refer to **Figure 6.2** for all available synthetic impedance switch settings.

SW#21 - #24: Current Limit

These four switches control the current-limit settings for the amplifier. When all four switches are

ON = DIP Switch UP OFF = DIP Switch DOWN				
SW#21	SW#22	SW#23	SW#24	Current Limit
ON	ON	ON	ON	160A
ON	ON	ON	OFF	150A
ON	ON	OFF	ON	140A
ON	ON	OFF	OFF	130A
ON	OFF	ON	ON	120A
ON	OFF	ON	OFF	110A
ON	OFF	OFF	ON	100A
ON	OFF	OFF	OFF	90A
OFF	ON	ON	ON	80A
OFF	ON	ON	OFF	70A
OFF	ON	OFF	ON	60A
OFF	ON	OFF	OFF	50A
OFF	OFF	ON	ON	40A
OFF	OFF	ON	OFF	30A
OFF	OFF	OFF	ON	20A
OFF	OFF	OFF	OFF	10A

Figure 6.3 – Current Limit Switch Configurations

in the UP position (default), the amplifier's output current is limited to 160A. The current-limit can be lowered in 10A increments by setting one or more of the current limit switches in the DOWN position. Refer to **Figure 6.3** for all available current-limit switch settings.

NOTE: If all four current-limit DIP switches are set in the DOWN position, the amplifier's output current will be limited to 10A.

6.2 Custom Compensation

If you wish to change one of the two standard compensations to a custom compensation, please contact **AE Techron Technical Support** for specific instructions.

7 Applications

7.1 Emergency Standby Switch or Safety Interlock

The two 9-pin D-Sub connectors on the amplifier back panel (Interlock A and Interlock B) can be used to remotely place the amplifier in Standby mode. This can provide a valuable safety feature, such as in creating a safety interlock for a cabinet in which one or more 8704 amplifiers are installed or wiring an emergency stop switch to the cabinet front or another accessible location.

The Remote Standby functions the same as the amplifier's front-panel Standby-Run switch by placing the amplifier in Standby mode. When an 8704 amplifier is in Standby mode, the low-voltage transformer is energized but the high-voltage transformers are not. By using a Remote Standby switch, all amplifiers in a multi-amp system can quickly and reliably be placed in Standby mode simultaneously. A Remote Standby switch also eliminates mechanical wear on the amplifier's front-panel Standby-Run switch.

To use this function, wire a switch using Pin1 (Interlock) and either Pin 3 or Pin 6 (Ground), as shown in **Figure 7.1**. Note that either the Interlock A connector or the Interlock B connector can be used.

In multi-amp systems, the unused Interlock A connector on the Master amplifier or the unused Interlock B connector on the last Follower amplifier can be used to wire the safety interlock.

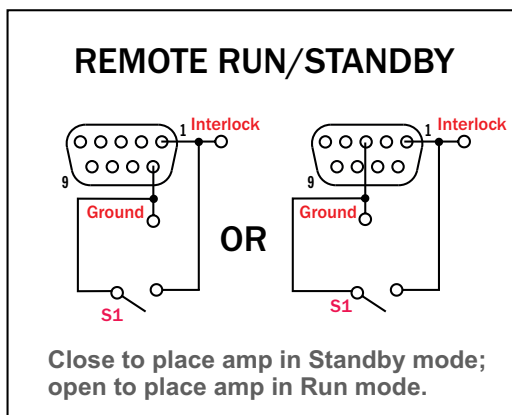

Figure 7.1 – Using the Interlock A or Interlock B connector to wire a safety interlock switch

7.2 Controlled-Voltage vs. Controlled-Current Modes of Operation

AE Techron 8704 amplifiers can be field-configured to operate as **Voltage Amplifiers** (Voltage-Controlled Voltage Source) or as **Transconductance Amplifiers** (Voltage-Controlled Current Source). The mode selection is made via the back-panel DIP switch #4. See the **Advanced Configuration** section for more information.

When configured as a **Controlled-Voltage** source (voltage amplifier), the amplifier will provide an output voltage that is constant and proportional to the control (input) voltage. If the load's impedance changes, the amplifier will seek to maintain this ratio of input to output voltage by increasing or decreasing the current it produces, as long as it is within the amplifier's ability to create the required current. Use this mode if you want the output voltage waveform to be like the input waveform (see **Figure 7.2**).

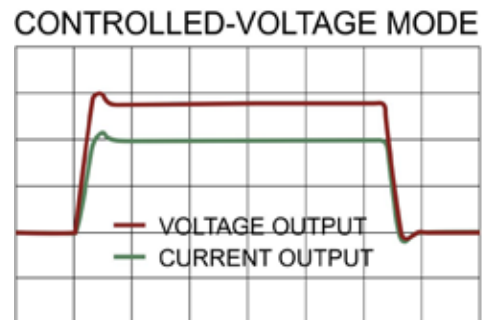

Figure 7.2 – Input to Output Comparison, Controlled-Voltage Operation

Conversely, when configured as a **Controlled-Current** source (transconductance amplifier), the amplifier will provide an output current that is constant and proportional to the control (input) voltage. If the load's impedance changes, the amplifier will seek to maintain this transconductance (ratio of input voltage to output current) by increasing or decreasing the voltage it produces, as long as it is within the amplifier's ability to create the required voltage. Use this mode if you want the output current waveform to be like the input waveform (see **Figure 7.3**).

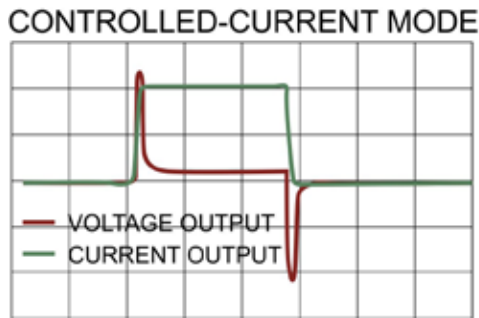

Figure 7.3 – Input to Output Comparison, Controlled-Current Operation

7.2.1 Safety and Operation Considerations for Controlled Current Operation

When an AE Techron amplifier is configured as a Controlled-Current source, care needs to be exercised in its operation. **Any voltage controlled current source should never be turned on without a load, (with some impedance, real or effective) connected to its output terminals.**

When asked to operate in this way, any current source (including an AE Techron amplifier) will increase its output voltage in an attempt to drive the requested current into the load. In an open-circuit condition, creating current flow will be impossible. The current source will increase its output voltage until it reaches its voltage limit. This is a potentially dangerous condition for both the AE Techron amplifier and for any user who might come in contact with the amplifier output terminals.

Likewise, operation in Controlled Current mode into a load that is completely resistive is **NOT recommended**. The load must have some inductance for Controlled Current mode to operate correctly.

When operating in Controlled-Current (CC) mode, a compensation circuit is required to ensure accurate output current. Since the load is a critical circuit component in CC mode, the inductive and resistive values of the load will determine the required compensation values.

One of the two compensation settings that can be enabled with DIP switch settings will be sufficient for most applications. If you determine that neither Compensation Network 1 or Compensation Network 2 will be adequate for your application and load, please contact **AE Techron Technical Support** for additional compensation options.

The following section describes methods for determining proper compensation setting for your application when operating in Controlled-Current mode.

7.2.2 Selecting Compensation for CC Operation

AE Techron 8704 amplifiers can be configured for either Controlled Voltage (CV) or Controlled Current (CC) mode of operation. When operating the amplifier in Controlled Voltage (CV) mode, compensation is not required. However, when operating in Controlled Current (CC) mode, the amplifier load becomes an integral part of the system. In order to ensure system stability and to control available bandwidth, compensation via an RC network is required for CC operation. The following steps will show you how to determine the proper compensation network for your load to allow you to operate your amplifier in CC mode safely and effectively.

STEP 1: Check Amplifier Operation in CV mode.

We recommend that you power-up and enable the amplifier in Controlled Voltage mode without attaching a load before configuring your amplifier for Controlled Current operation. This will allow you to verify that the input signal and the amplifier are operating correctly.

Once this initial check is completed, power down the amplifier, attach your load, and move the back-panel Operation Mode DIP switch (SW#4) to the DOWN position to place the amplifier in CC mode.

STEP 2: Determine Required Compensation.

When operating an amplifier in Controlled-Current mode, the load becomes an integral part of the system. In order to determine the required compensation for your load, consulting the following table to determine the approximate compensation capacitance (CC) required based on the inductance of your load. Note that these calculations are based on empirical measurements and are approximate.

NOTE: Load Resistance (R) is assumed to be <5 ohms.

Load Inductance (L)	Compensation Capacitance (CC)	Compensation Network
75 μ H to 1 mH	0.0022 μ F	Network 1
1 mH to 5 mH	0.0100 μ F	Network 2

STEP 3: Enable Compensation Network

If your load inductance is between 75 μ H and 1 mH, and your load resistance is less than 5 ohms, then you can likely use Compensation Network 1 for your application. If your load inductance is between 1 mH and 5 mH, and your load resistance is less than 5 ohms, then you can likely use Compensation Network 2 for your application. (See **Figure 7.4**). These compensation networks

are enabled when Compensation Network 1 DIP switch (SW#6) or Compensation Network 2 DIP switch (SW#5) on the Master amplifier module is set to the ON (UP) position.

If your load inductance falls outside of these ranges, or if your load resistance is greater than 5 ohms, please contact **AE Techron Technical Support** for assistance.

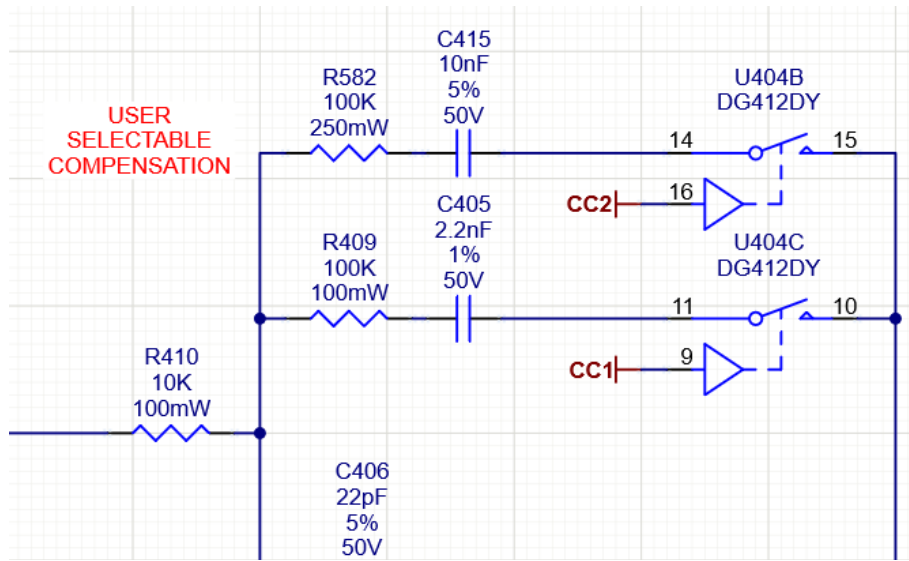

Figure 7.4 – Selectable factory-installed compensation networks

STEP 4: Verifying Operation

Remember the load you are connecting is a part of the system and the amplifier should not be turned on without the load being connected.

After selecting and enabling your choice of Compensation Network, check to ensure that the Operation Mode DIP switch is set to CC (DOWN), then power up the amplifier without signal input.

To begin testing, input a square wave with a frequency of 100 Hz to 1 kHz, or a squared pulse at a low level (typically 0.25 to 2.0 volts). A limited-rise-time, repetitive pulse of low duty cycle is preferred.

Observe the output current through a current monitor or current probe. Look for clean transition edges. The presence of ringing or rounding on the

transition edges indicates compensation problems. (See **Figure 7.5**.)

If a change in compensation is necessary, please contact **AE Techron Technical Support** for assistance. **DO NOT** operate your amplifier in Controlled Current mode without proper compensation.

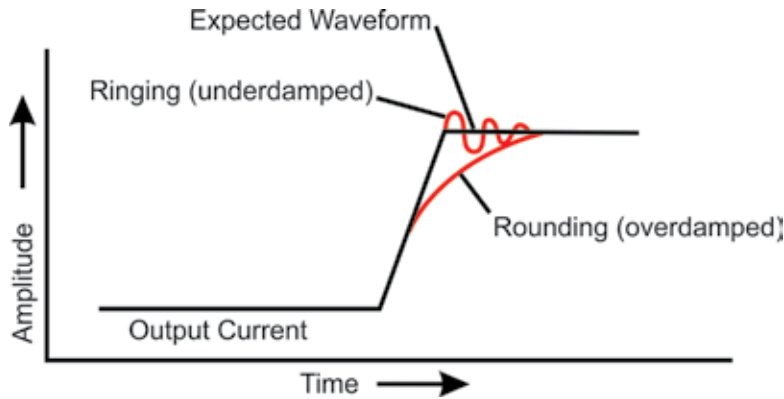

Figure 7.5 – Compensation Effects on Waveform

7.3 Driving Reactive Loads

Like all switching amplifiers, 8704 amplifiers are able to reuse the energy returned from reactive loads. Unlike purely resistive loads, loads with some reactance (either capacitive or inductive) will store energy during part of a cycle, and then release some of this energy back later. This energy is transferred back to the load through the amplifier's power supply. This allows the amplifier to deliver continuous apparent power that is up to four times the rated power of the amplifier when driving reactive loads.

7.4 8704 Multi-amp Systems

The 8704 amplifier may be used with one other 8704 amplifier in either a Parallel or a Push/Pull (Series) configuration. The Parallel configuration will approximately double the continuous current output to 120 Arms, while the Push/Pull configuration will approximately double the voltage available from a single 8704 amplifier to 500 Vrms (see **Figure 7.6**).

CONFIGURATION	CONTINUOUS OUTPUT (100% Duty Cycle)
Two 8704 in Parallel Configuration	250 Vrms / 120 Arms
Two 8704 in Push/Pull Configuration	500 Vrms / 60 Arms

Figure 7.6 – Typical Output Levels for 8704 Multiamp Systems

While it is possible to operate a multi-amp system in either Controlled Voltage or Controlled Current modes of operation, multi-amp operation in Controlled Current mode requires additional configuration of the equipment. Please contact **AE Techron Tech Support** for assistance with configuring a multi-amp system for Controlled Current operation.

For routine, Controlled-Voltage applications, two-amplifier Parallel and Push/Pull systems can be configured using two standard 8704 amplifiers and the **8000 Series Multiamp Kit** (part number 69-8005462) which is available from AE Techron:

The 8000 Series Mutltamp Kit contains two 9-pin



Figure 7.7 – 8000 Series Multiamp Kit

D-sub cables, one for connecting two 8704 amplifiers in a parallel configuration, the other for connecting two 8704 amplifiers in a push/pull configuration. The kit also contains the output cable assembly to be used to connect the amplifier system to the load in parallel configurations. See **Figure 7.7**.

Please contact AE Techron's **Sales Department** for more information about the 8000 Series Multi-amp Kit..

7.4.1 Multiamp Safety Principles

Following these basic principles will help to ensure the safety of your equipment and personnel.

One Master Amplifier

Multi-amp configurations require one amplifier configured as a Master amplifier, and the second amplifier in the system configured as a Follower amplifier.

If you wish to connect more than two 8704 amplifiers in parallel, please contact AE Techron Tech Support for additional information and support.

Use Only 8704 Amplifiers

Use only AE Techron 8704 amplifiers to construct a 8704 multiamp system. Do not combine different models of AE Techron amplifiers in the same system or use amplifiers made by another manufacturer in a 8704 multiamp system. Such improper connections could damage the amplifiers.

Use Proper Output Wiring

Select wire appropriate for your application, load and expected output. Parallel systems with a low-impedance load running high-current, continuous-duty applications may require 1/0 AWG or more. Please refer to an AWG wire sizes chart or the equivalent to determine the appropriate wire for your application.

Wire rating refers to the allowable voltage handled by the wire. In configuring Push/Pull systems for increased voltage, make sure that the wire insulation on output wiring is appropriate for the expected output voltage. Wire length should also be limited to 20 feet to minimize voltage drop.

Never directly connect one amplifier's OUTPUT terminal to another amplifier's OUTPUT terminal, unless the Electronic Gain Matching option has been selected (see the **Advanced Configuration** section of the product manual for more information). The resulting circulating currents will waste power and may damage the amplifiers.

7.4.2 Parallel Multi-amp Configuration

To configure and connect two amplifiers for operation in a parallel configuration, begin by designating one amplifier as the Master amplifier, and the other amplifier as a Follower amplifier. Consider placing a "Master" or "Follower" label on each amplifier's back panel to clarify the amplifier designation during setup and operation.

Testing Setup

The two amplifiers will be connected in a parallel configuration **except for the OUTPUT terminals, which will be left open.**

Complete the following steps to configure and connect the two amplifiers for gain testing.

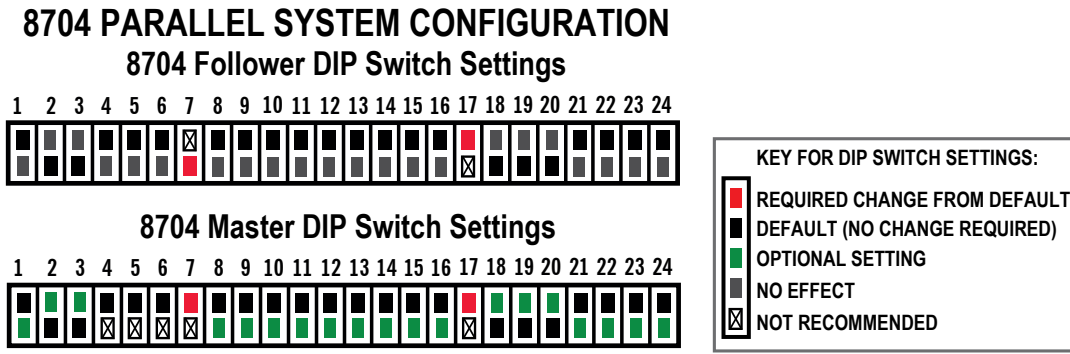

Figure 7.8 – Required DIP switch settings for parallel amplifiers

1. Refer to **Figure 7.8** to configure each amplifier's DIP switches for parallel operation. On the amplifier designated as Follower, **set DIP switch #7 in the DOWN (Follower) position**. On both amplifiers, **set DIP switch #17 in the UP (Electronic Gain Matching ON) position**. Note that other configuration settings controlled by DIP switches can also be selected before operation. In an 8704 multi-amp system, **all settings except for Control Configuration (SW#7) and Electronic Gain Matching**

(SW#17) are controlled by the Master amplifier. For these additional configurations, setting of the DIP switches on the Follower amplifier is not required.

2. Place the Follower amplifier on top of the Master amplifier, and then connect the black wires of the output cable assembly (provided in the 8000 Series Multi-amp Kit) to the GND output terminal of the Master and Follower amplifiers as outlined below and as shown in **Figure 7.9**.

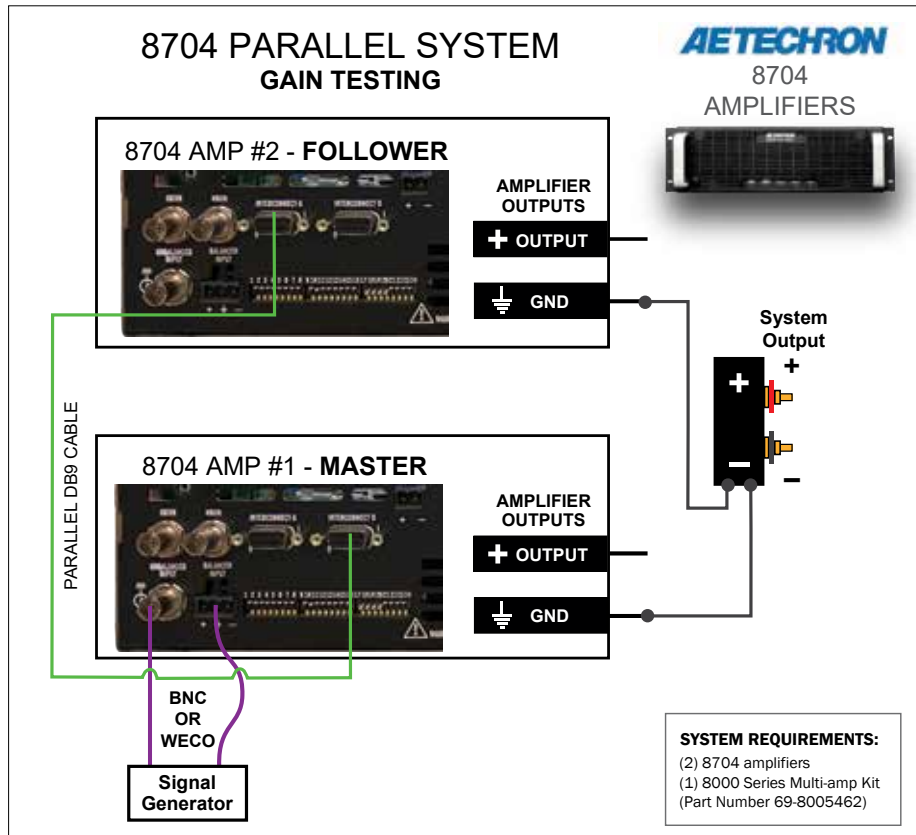

Figure 7.9 – Connecting the two amplifiers for parallel system gain testing

- A. Remove the back-panel output covers from both amplifiers.
 - B. Remove the 3/8-inch nuts from the GND terminals on both amplifiers.
 - C. Connect the end of one of the black wires on the output cable assembly to the GND terminal of the Master amplifier
 - D. Connect the end of the other black wire on the output cable assembly to the GND terminal of the Follower amplifier.
 - E. Replace the 3/8-inch nuts on both terminals. **IMPORTANT: Torque the nuts to 10 lbs./foot.**
 - F. **DO NOT connect the red wires on the output cable assembly. Do not connect the output cable assembly to a load at this time.**
3. Connect the Parallel 9-pin D-sub cable (DB9 cable labeled "Parallel" from the 8000 Series Multi-amp Kit) from the back-panel Interconnect B port on the Master amplifier to the Interconnect A port on the Follower amplifier.
 5. Connect channel one of the oscilloscope between the Master amplifier's Output and GND connectors.
 6. Adjust your signal source to input a 1 kHz, 2.5 Vrms sinewave into the Master amplifier input. The measured output should be at or very near to 100 Vrms.
 7. Check the accuracy between the oscilloscope channels by connecting channel two of the oscilloscope between the Master amplifier's Output and GND connectors. The measured output should be the same as the output recorded on channel one.
 8. Move the channel two probes to connect between the Follower amplifier's Output and GND connectors.
 9. Observe the measured output on the two channels. Confirm that the signals are in phase and that the difference in measured output is less than 0.5V.

IMPORTANT: If the difference in output between the two amplifiers is greater than 0.5V, DO NOT complete the system setup. Contact AE Techron Technical Support for assistance.

Amplifier Gain Testing

Gain testing can be performed using an oscilloscope or a floating digital multimeter with a resolution of at least three digits. Both testing methods are provided below.

Testing Using an Oscilloscope

1. Connect from a signal generator to the BNC or WECO signal input connector on the back panel of the Master amplifier. Note that if the WECO connector is used for signal input, DIP switch #1 on the Master amplifier should be placed in the DOWN (OFF) position and DIP switch #2 should be placed in the UP (ON) position.
2. Turn down the level of your signal source.
3. Make sure the back-panel breaker switch on both amplifiers is in the ON position, and then press the Standby-Run switch on each amplifier's front panel to energize the amplifiers.
4. Wait for the green RUN LED to illuminate on the amplifier.

Testing Using a Floating Digital Multimeter

1. Connect from a signal generator to the BNC or WECO signal input connector on the back panel of the Master amplifier. Note that if the WECO connector is used for signal input, DIP switch #1 on the Master amplifier should be placed in the DOWN (OFF) position and DIP switch #2 should be placed in the UP (ON) position.
2. Turn down the level of your signal source.
3. Make sure the back panel breaker switch on both amplifiers is in the ON position, and then press the Standby-Run switch on each amplifier's front panel to energize the amplifiers.
4. Wait for the green RUN LED to illuminate on the amplifier.
5. Connect the digital multimeter between the Master amplifier's Output and GND connectors.

6. Adjust your signal source to input a 1 kHz, 2.5 Vrms sinewave into the Master amplifier input. The measured output should be at or very near to 100 Vrms. Record the measured output.
7. Connect the digital multimeter between the Follower amplifier's Output and GND connectors. The measured output should be at or very near to 100 Vrms. Record the measured output.
8. Set your multimeter to measure AC volts RMS at a low scale, then connect between the Master Output connector and the Follower Output connector. The measured output should be less than 0.5V.

IMPORTANT: If the difference in output between the two outputs is greater than 0.5V, DO NOT complete the system setup. Contact AE Techron Technical Support for assistance.

Connect the Output Cables

1. **Make sure both amplifiers are disconnected from AC power.**

2. Connect the red wires of the output cable assembly to the terminals on the Master and Follower amplifiers labeled "Output" as described below and as shown in **Figure 7.10**.
 - A. Remove the back-panel output covers from both amplifiers.
 - B. Remove the 3/8-inch nuts from the Output terminals on both amplifiers.
 - C. Connect the end of one of the red wires on the output cable assembly to the Output terminal of the Master amplifier
 - D. Connect the end of the other red wire on the output cable assembly to the Output terminal of the Follower amplifier.
 - E. Replace the 3/8-inch nuts on both terminals. **IMPORTANT: Torque the nuts to 10 lbs./foot.**
 - F. **DO NOT connect the output cable assembly to a load at this time.**
7. Replace the output terminal covers on both amplifiers and secure.

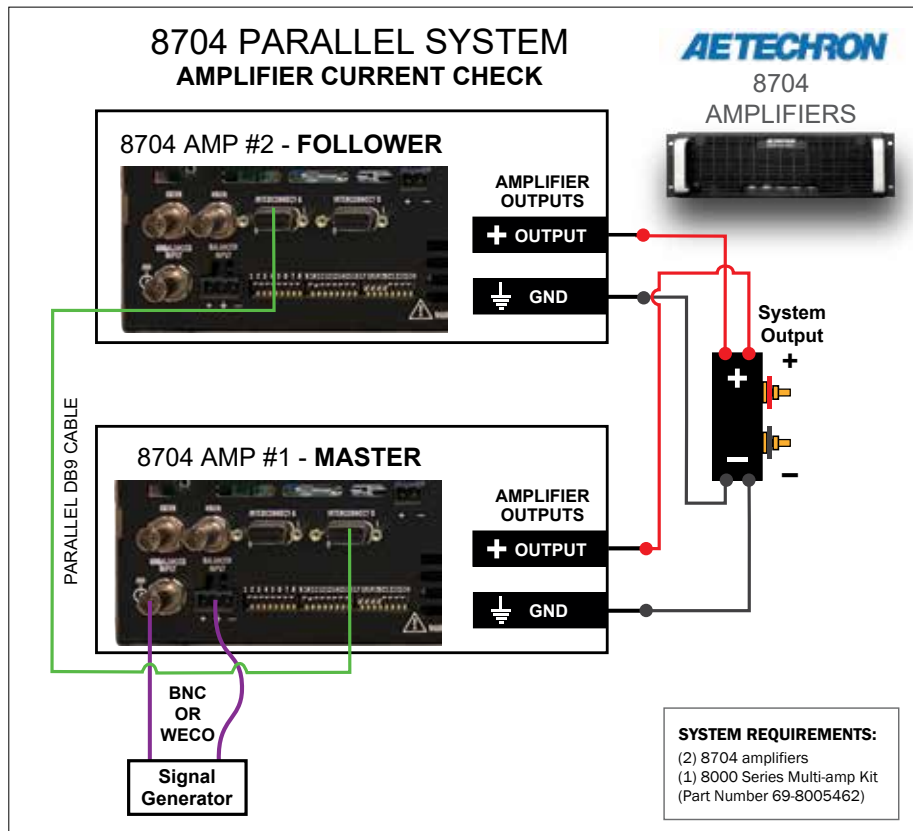

Figure 7.10 – Connecting the two amplifiers for amplifier current check

Amplifier Current Check

1. Connect an oscilloscope or other measuring device to the back panel BNC connectors labeled IMON on both the Master and the Follower amplifiers.
2. Turn down the level of your signal source.
3. Make sure both amplifier's back panel breaker switches are in the ON position, and then press the Standby-Run switch on each of the amplifier's front panels to energize the amplifiers.
4. Wait for the green RUN LED to illuminate on the amplifier.
5. Adjust your signal source to input a 1-kHz sine wave of 100 mV into the amplifier system.
6. Measure the current being produced at the output of the IMON on each amplifier (1V = 20A). Be sure to measure AC voltage at the IMON port as an RMS value. Apart from switching current, no significant current should be observed. Current output should be less than 2A (0.1V on the IMON output).
7. If no significant current is observed in either amplifier, continue with the system setup. **IMPORTANT: If current exceeds 2A (0.1V) from either amplifier, DO NOT complete the system setup. Contact AE Techron Technical Support for assistance.**
8. Slowly raise the input voltage from 100 mV to 2.5V while continuing to monitor current at

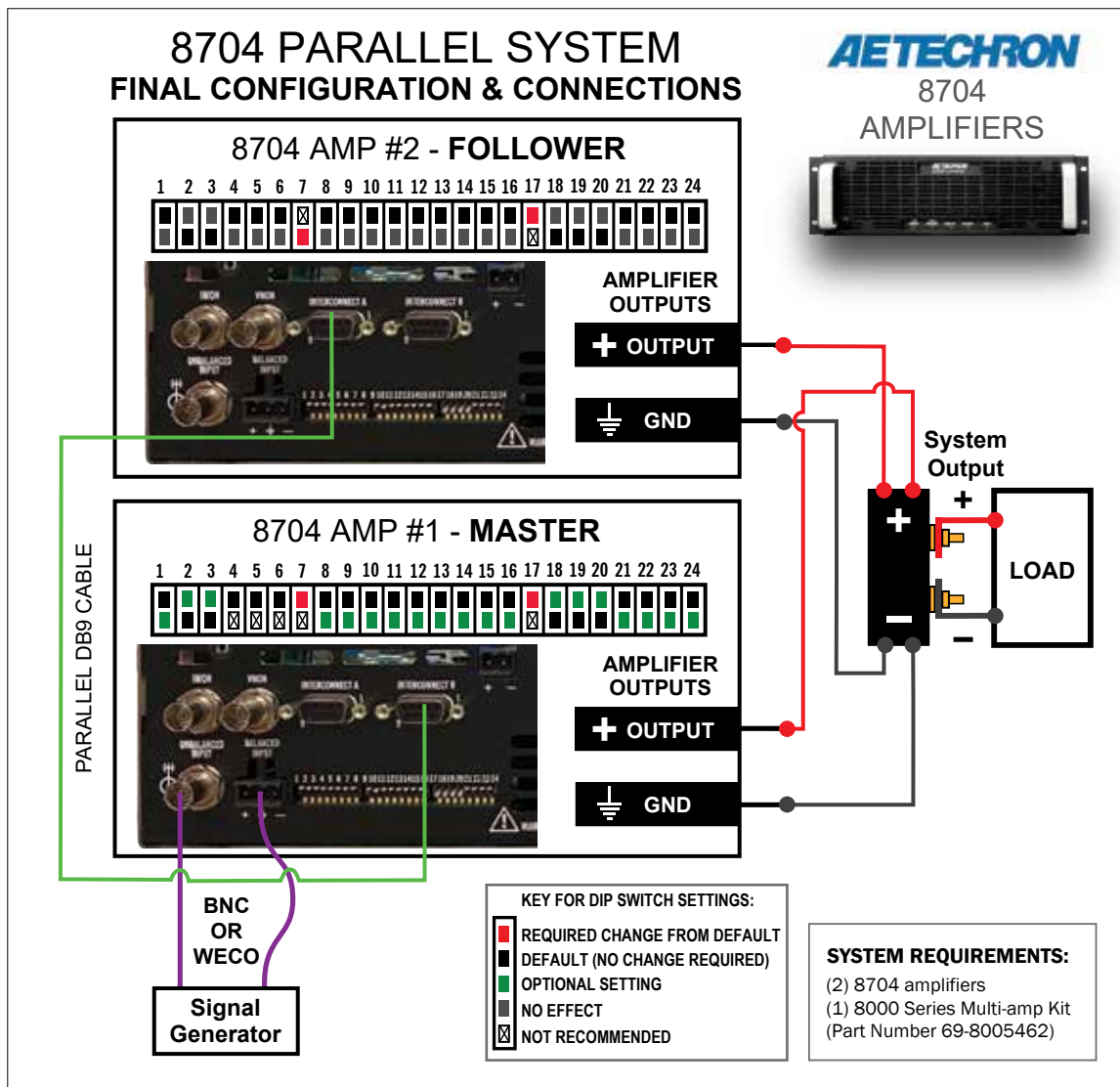

Figure 7.11 – 8704 parallel system setup

IMON. IMPORTANT: If current exceeds 2A (0.1V) from either amplifier at any time, DO NOT complete the system setup. Contact AE Techron Technical Support for assistance.

Connect the Load

1. **Make sure both amplifiers are disconnected from AC power.**
2. Build two cables for output wiring. The wires should be sized for an expected output that is 2X the output of a single 8704 amplifier, and should be terminated into a spade lug, ring terminal or other terminal suitable for the system output and adaptable to the connectors on your load.
3. Connect one output cable from the negative terminal of the output cable assembly to the ground terminal of your load.
4. Connect the second output cable from the positive terminal of the output cable assembly to the positive terminal of your load.

Refer to **Figure 7.11** for completed system wiring.

7.4.3 Push/Pull Multi-amp Configuration

To configure and connect two amplifiers for operation in a Push/Pull (series) configuration, begin by designating one amplifier as the Master amplifier, and the other amplifier as a Follower amplifier. Consider placing a “Master” or “Follower” label on each amplifier’s back panel to clarify the amplifier designation during setup and operation.

IMPORTANT: Make sure both amplifiers are disconnected from AC power.

DIP Switch Settings

On the amplifier designated as Follower, **set DIP switch #7 in the DOWN (Follower) position.** Refer to **Figure 7.12** for the required DIP switch settings for testing Push/Pull amplifiers.

Note that other configuration settings controlled by DIP switches can also be selected before operation. In an 8704 multi-amp system, **all settings except for Control Configuration (SW#7) and Electronic Gain Matching (SW#17) are controlled by the Master amplifier.** For these additional configurations, setting of the DIP switches on the Follower amplifier is not required.

Amplifier Wiring

Refer to **Figure 7.13** and make the following connections to the Master and Follower amplifiers.

1. Connect the Push/Pull 9-pin D-sub cable (DB9 cable labeled “Push/Pull” from the 8704 Multi-amp Kit) from the back-panel Interconnect B port on the Master amplifier to the Interconnect A port on the Follower amplifier.
2. Connect from a signal generator to the BNC or WECO signal input connector on the Master amplifier’s back panel. Note that if the WECO signal input connector is used, DIP switch #1 should be placed in the DOWN (OFF) position and DIP switch #2 should be placed in the UP (ON) position.
3. Build your output cables:
 - A. Build two cables for output wiring. The wires should be terminated at one end into a spade lug, ring terminal or other terminal suitable for the system output and

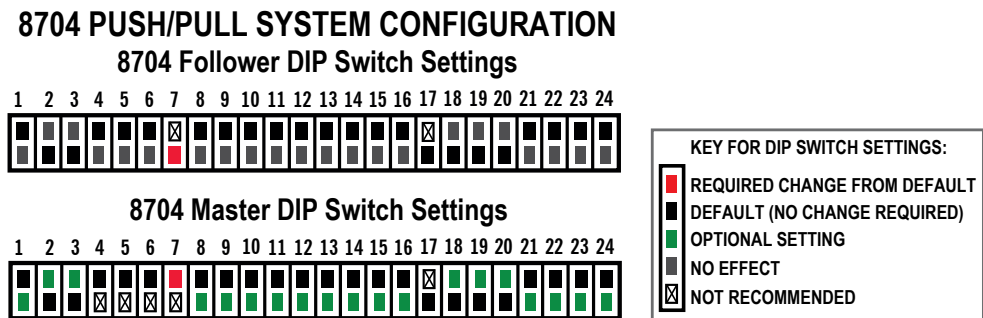

Figure 7.12 – Required DIP switch settings for Push/Pull amplifiers

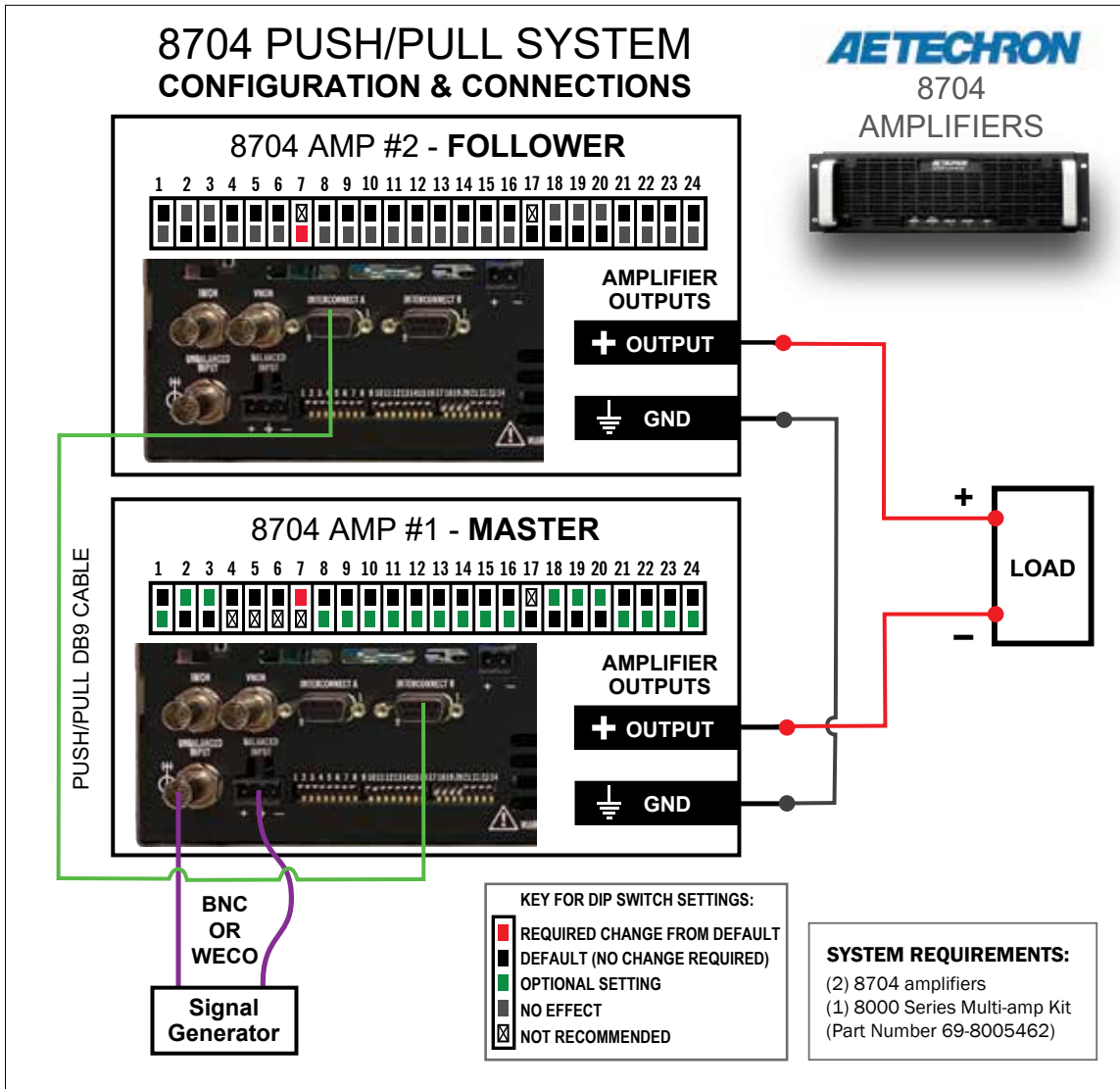

Figure 7.13 – 8704 Push/Pull system setup

4. Connect the Load
 - A. **Make sure both amplifiers are disconnected from AC power.**
 - B. Remove the back-panel output covers from both amplifiers.
 - C. Remove the 3/8-inch nuts from the Output and GND terminals on both amplifiers.
 - D. Connect the Bridge cable from the GND terminal on the Master amplifier to the GND terminal on the Follower amplifier.
 - E. Connect the two output cables. Connect one cable from the Output terminal of the Master amplifier to one terminal on your load. Connect the other output cable from the Output terminal on the Follower amplifier to the other terminal on your load.
 - F. Replace the 3/8-inch nuts on all four output terminals. **IMPORTANT: Torque the nuts to 10 lbs./foot.**

- G. Replace the output terminal covers on both amplifiers and secure.

7.4.4 Multiamp System Start-up Procedure

1. Turn down the level of your signal source.
2. Make sure the back panel breaker switch on both amplifiers is in the ON position.
3. Press the Standby-Run switch on both the Master and the Follower amplifier to energize the amplifiers. Energizing the Master amplifier first is recommended, although not absolutely required.
4. Wait for the green RUN LEDs to illuminate on both amplifiers.
5. Adjust the input signal level to achieve the desired output level.

7.4.5 Multiamp System Operation

In multiamp systems, the Master amplifier controls several operating functions for both amplifiers in the system, so the Follower amplifier is said to be “interlocked” with the Master amplifier. The functions controlled by the Master amplifier include input signal, operating status, mode of operation (controlled-voltage or controlled-current operation) and amplifier compensation.

Because the amplifiers in a multiamp system are interlocked, the main and fault status indicators of both amplifiers in the system must be considered to determine the current status and the necessary remedies to return the system to operational status when a fault condition occurs.

Run/Standby Indicators

When each amplifier in a multi-amp system is energized, the amplifier will be placed in Standby mode (Run/Standby LED solid amber) and remain in Standby mode until both amplifiers in the system have been energized. The system will automatically proceed to Run mode when both amplifiers are energized and achieve Standby mode.

Switching the Standby-Run switch on either amplifier to the Standby position will place both the amplifiers in Standby mode.

Signal/Overload Indicators

When an input signal is presented to the Master amplifier at a level greater than 0.5V, the Signal/Overload indicators on both amplifiers will light solid green. When signal distortion greater than 0.1% is sensed by the Master amplifier, the Signal/Overload indicators on both of the amplifiers will flash amber.

Fault Status Indicators

The three Fault Status indicators located on each amplifier's front panel are used to monitor the internal conditions of the amplifier and will illuminate when a fault condition occurs. Both amplifiers will be placed in Standby mode when a fault condition occurs.

Over/Under Line: This fault condition will occur when the detected AC mains voltage is outside of the operable range of the amplifier ($\pm 10\%$). This can occur if the amplifier's back-panel breaker is not in the on position (right), or if the AC supply into the amplifier is higher or lower than the operable range.

To remove the system from Standby, the AC mains must be brought to within the optimal range. First, check to make sure the amplifier's back-panel breaker on both amplifiers is turned on. Next, check the voltage level of the AC supply.

Once the fault condition has been cleared, both amplifiers will return automatically to Run mode. If the High/Low-Line indicator does not turn off or if the system does not return from Standby, one or both amplifiers may require servicing. See the **Troubleshooting** section in this manual for more information.

Overtemp: Both amplifiers monitors the temperature inside its high-voltage transformers and in the output stage heat sinks. The amber Overtemp indicator will light and the system will be placed in Standby mode when the temperature sensors in either amplifier detect a condition that would damage the amplifier. If the Overtemp pulse is extremely short, as in the case of defective wiring

or switches, this indicator may be lit too briefly to observe.

To remove the system from Standby, make sure the fans in both amplifiers are running and then remove the input signal from the system. Allow the fans to run until the system automatically returns to Run mode. See the **Troubleshooting** section in this manual for information on identifying and correcting the cause of an Overtemp fault condition.

Fault: If the red Fault indicator lights on one or both amplifiers, the system will be placed in Standby. An amplifier may report a Fault status under two conditions:

1. High frequency oscillation is causing high shoot-through current.
2. An output transistor has shorted, causing the output fault condition.

Cycle the front-panel Standby-Run switch (Standby, then Run) on the amplifier(s) reporting the Fault condition to reset each amplifier. When any amplifier reporting a fault has been reset, cycle the Standby-Run switch on the other amplifier to return the system to Run mode.

On either amplifier in the system, if the fault condition recurs or does not clear, the amplifier may require servicing. See the **Troubleshooting** section in this manual for more information. Repair or replace the faulty amplifier to re-enable the system.

8 Maintenance

Simple maintenance can be performed by the user to help keep the equipment operational. The following routine maintenance is designed to prevent problems before they occur. See the **Troubleshooting** section, for recommendations for restoring the equipment to operation after an error condition has occurred.

Preventative maintenance is recommended after the first 250 hours of operation, and every three months or 250 hours thereafter. If the equipment environment is dirty or dusty, preventative maintenance should be performed more frequently.

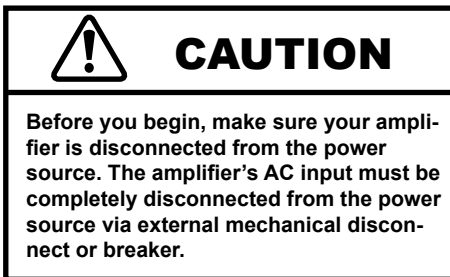

8.1 Clean Amplifier Filter and Grills

8.1.1 Tools Required

The recommended equipment and supplies needed to perform the functions required for this task are described as follows.

- Vacuum cleaner
- Damp cloth (use water only or a mild soap diluted in water)

To ensure adequate cooling and maximum efficiency of the internal cooling fans, the amplifier's front and rear grills should be cleaned periodically. To clean the amplifier grills and filter, complete the following steps:

1. Disconnect the amplifier from its power source via external mechanical disconnect or breaker.
2. The front grill is secured to the amplifier front panel by magnets. Pull out on the grill to release it from the front panel.
3. Remove the filter located behind the front grill.
4. Using a vacuum cleaner, vacuum the front ventilation grill, the grill filter, and the back ventilation exit grill.
5. Using a damp cloth, clean the amplifier front panel and the rear ventilation grills. Also use the damp cloth to clean the front grill and filter. If necessary, these can be immersed in warm, soapy water.
6. Dry the front panel, filter, and grills with a clean cloth or allow to air dry. **IMPORTANT: All parts should be completely dry before reconnecting or restarting the amplifier.**
7. Reinstall the filter and replace the amplifier front grill.



9 Troubleshooting

9.1 Introduction & Precautions

This section provides a set of procedures for identifying and correcting problems with the 8704 amplifier. Rather than providing an exhaustive and detailed list of troubleshooting specifications, this section aims to provide a set of shortcuts intended to get an inoperative amplifier back in service as quickly as possible.

The procedures outlined in this section are directed toward an experienced electronic technician; it assumes that the technician has knowledge of typical electronic repair and test procedures.

9.2 No Signal

Missing output signal may be caused by one of the following:

1. The Control Configuration DIP switch (#7) is set to the Follower (down) position. The amplifier should only be configured for Follower operation if it is in a multi-amplifier system; otherwise this DIP switch should be set to the Master (up) position. See the **Advanced Configuration** section in this manual for more information.
2. A signal source is not connected to either inputs on the amplifier. See the **Amplifier Setup** section in this manual for more information.

9.3 No LEDs Illuminated

If none of the LEDs on the Display Panel are illuminated, check the following:

1. The AC mains are not connected or not on (see the **Amplifier Setup** section for more information).

9.4 Over/Under Line LED Lit

The amplifier will protect itself from AC mains voltage that is 10% above or below the voltage indicated on the back panel. This can occur if the amplifier's back-panel breaker is not in the on position (right), or if the AC supply into the amplifier is higher or lower than the operable range.

First, check to make sure the amplifier's back-panel breaker is turned on. Next, check the voltage level of the AC supply. If the AC mains voltage is more than 10% outside the range of the operating voltage, increase or reduce the AC mains voltage to the proper level. When the line voltage condition is corrected, the amplifier will automatically return to Run mode. If the amplifier does not reset, the amplifier's internal transformers may need to be replaced. Please see the **Factory Service** information at the end of this section.

9.5 Run/Standby LED Remains Amber

When the Run/Standby LED is lit solid amber, the amplifier is in Standby mode. Press the Standby-Run switch to the Run position to place the amplifier in Run mode.

If the amplifier does not return to run mode, check to see if the High/Low Line, Overtemp, or Fault LEDs are lit, and then follow the instructions in this section for remedying the fault condition and returning the amplifier to Run mode.

If the remedies given fail to restart the amplifier, the amplifier may require servicing. See the Factory Service Information at the end of this section.

9.6 Amplifier Overheats (Over Temp Fault Condition)

There are two possible reasons why the 8704 amplifier is overheating: Excessive power requirements or inadequate airflow.

9.6.1 Excessive Power Requirements

An amplifier will overheat if the required power exceeds the amplifier's capabilities. High duty cycles and low-impedance loads are especially prone to cause overheating. To see if excess power requirements are causing overheating, check the following:

1. The application's power requirements fall within the specifications of the amplifier. See the amplifier's Datasheet to verify operating parameters.
2. Faulty output connections and load.

3. Undesired DC offset at the Output and Input signal.

If the amplifier chronically overheats with suitable power/load conditions, then the amplifier may not be receiving adequate airflow. To check for adequate airflow, proceed with the following steps:

9.6.2 Check for Inadequate Airflow

1. Check air filters. Over time they can become dirty and worn out. It is a good idea to clean the air filters periodically with a mild detergent and water.
2. Visually inspect fans to assure correct operation while amplifier is On (I). Any inoperative, visibly slow, or reverse-spinning fan should be replaced. Please see the Factory Service information at the end of this section.

An OverTemp condition places the amplifier in Standby mode. If the OverTemp pulse is extremely short, as in the case of defective wiring or switches, the OverTemp pulse may be too brief to observe.

9.6.3 Resetting After OverTemp

To reset the amplifier after an OverTemp has occurred, make sure fans are running. Remove the input signal from the amplifier and allow the fans to run until the amplifier has cooled sufficiently and the amplifier automatically returns to Run mode.

NOTE: Typically, overheating that occurs in the amplifier outputs due to inadequate airflow or very low impedance loads will clear within 5 minutes. Overheating in the amplifier transformers due to excessive power requirements will take from 5 to 15 minutes to clear. Timing the cool-down period for the amplifier may help to determine the cause of the overheating.

If the fault condition does not clear, return the amplifier for Factory Service.

9.7 Fault LED is Illuminated

The 8704 contains protection circuitry that disables the amplifier if an output stage is behaving abnormally. This usually indicates an output transistor has shorted.

To clear the Fault condition, follow these steps:

1. Turn off the signal source.
2. Turn off the AC mains.
3. Turn AC mains power back on. If the Fault LED doesn't illuminate again, press the Standby-Run switch to place the amplifier in Run mode and turn the signal source on.
4. If the Fault LED is still illuminated and the Fault condition doesn't clear, return the amplifier for Factory Service. See the Factory Service information at the end of this section.

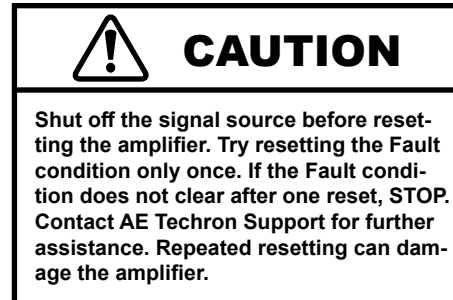

9.8 Factory Service

If the troubleshooting procedures are unsuccessful, the amplifier may need to be returned for Factory Service. All units under warranty will be serviced free of charge (customer is responsible for one-way shipping charges as well as any custom fees, duties, and/or taxes). Please review the Warranty at the beginning of this manual for more information.

All service units must be given Return Authorization by AE Techron, Inc. before being returned. Return Authorizations can be requested on our website or by contacting our Customer Service Department.

Please take extra care when packaging your amplifier for repair. It should be returned in its original packaging or a suitable alternative. Replacement packaging materials can be purchased for a nominal fee.

Please send all service units to the following address and be sure to include your Return Authorization Number on the box.

AE Techron, Inc.
Attn: Service Department / RMA#
2507 Warren Street
Elkhart, IN 46516

Appendix A: Gain DIP Switch Settings

Use this chart to determine the required settings for DIP switches 9 through 16 to achieve the amplifier gain you need for your application. Note: All

switches ON = Gain of 39.85, all switches OFF = gain of 0 (signal will not be amplified).

ON = DIP Switch UP OFF = DIP Switch DOWN								
SW#9	SW#10	SW#11	SW#12	SW#13	SW#14	SW#15	SW#16	Gain
ON	ON	ON	ON	ON	ON	ON	ON	39.85
ON	ON	ON	ON	ON	ON	ON	OFF	39.69
ON	ON	ON	ON	ON	ON	OFF	ON	39.54
ON	ON	ON	ON	ON	ON	OFF	OFF	39.38
ON	ON	ON	ON	ON	OFF	ON	ON	39.22
ON	ON	ON	ON	ON	OFF	ON	OFF	39.06
ON	ON	ON	ON	ON	OFF	OFF	ON	38.91
ON	ON	ON	ON	ON	OFF	OFF	OFF	38.75
ON	ON	ON	ON	OFF	ON	ON	ON	38.60
ON	ON	ON	ON	OFF	ON	ON	OFF	38.44
ON	ON	ON	ON	OFF	ON	OFF	ON	38.29
ON	ON	ON	ON	OFF	ON	OFF	OFF	38.13
ON	ON	ON	ON	OFF	OFF	ON	ON	37.97
ON	ON	ON	ON	OFF	OFF	ON	OFF	37.81
ON	ON	ON	ON	OFF	OFF	OFF	ON	37.66
ON	ON	ON	ON	OFF	OFF	OFF	OFF	37.50
ON	ON	ON	OFF	ON	ON	ON	ON	37.35
ON	ON	ON	OFF	ON	ON	ON		37.19
ON	ON	ON	OFF	ON	ON		ON	37.04
ON	ON	ON	OFF	ON	ON			36.88
ON	ON	ON	OFF	ON	OFF	ON	ON	36.72
ON	ON	ON	OFF	ON	OFF	ON		36.56
ON	ON	ON	OFF	ON	OFF	OFF	ON	36.41
ON	ON	ON	OFF	ON	OFF	OFF	OFF	36.25
ON	ON	ON	OFF	OFF	ON	ON	ON	36.10
ON	ON	ON	OFF	OFF	ON	ON		35.94
ON	ON	ON	OFF	OFF	ON		ON	35.79
ON	ON	ON	OFF	OFF	ON			35.63
ON	ON	ON	OFF	OFF	OFF	ON	ON	35.47
ON	ON	ON	OFF	OFF	OFF	ON		35.31
ON	ON	ON	OFF	OFF	OFF	OFF	ON	35.16
ON	ON	ON	OFF	OFF	OFF	OFF	OFF	35.00
ON	ON	OFF	ON	ON	ON	ON	ON	34.85
ON	ON	OFF	ON	ON	ON	ON	OFF	34.69
ON	ON	OFF	ON	ON	ON	OFF	ON	34.54
ON	ON	OFF	ON	ON	ON	OFF	OFF	34.38
ON	ON	OFF	ON	ON	OFF	ON	ON	34.22
ON	ON	OFF	ON	ON	OFF	ON	OFF	34.06
ON	ON	OFF	ON	ON	OFF	OFF	ON	33.91
ON	ON	OFF	ON	ON	OFF	OFF	OFF	33.75
ON	ON	OFF	ON	OFF	ON	ON	ON	33.60
ON	ON	OFF	ON	OFF	ON	ON	OFF	33.44

ON = DIP Switch UP OFF = DIP Switch DOWN								
SW#9	SW#10	SW#11	SW#12	SW#13	SW#14	SW#15	SW#16	Gain
ON	ON	OFF	ON	OFF	ON	OFF	ON	33.29
ON	ON	OFF	ON	OFF	ON	OFF	OFF	33.13
ON	ON	OFF	ON	OFF	OFF	ON	ON	32.97
ON	ON	OFF	ON	OFF	OFF	ON	OFF	32.81
ON	ON	OFF	ON	OFF	OFF	OFF	ON	32.66
ON	ON	OFF	ON	OFF	OFF	OFF	OFF	32.50
ON	ON	OFF	OFF	ON	ON	ON	ON	32.35
ON	ON	OFF	OFF	ON	ON	ON		32.19
ON	ON	OFF	OFF	ON	ON		ON	32.04
ON	ON	OFF	OFF	ON	ON			31.88
ON	ON	OFF	OFF	ON	OFF	ON	ON	31.72
ON	ON	OFF	OFF	ON	OFF	ON		31.56
ON	ON	OFF	OFF	ON	OFF	OFF	ON	31.41
ON	ON	OFF	OFF	ON	OFF	OFF	OFF	31.25
ON	ON	OFF	OFF	OFF	ON	ON	ON	31.10
ON	ON	OFF	OFF	OFF	ON	ON		30.94
ON	ON	OFF	OFF	OFF	ON		ON	30.79
ON	ON	OFF	OFF	OFF	ON			30.63
ON	ON	OFF	OFF	OFF	OFF	ON	ON	30.47
ON	ON	OFF	OFF	OFF	OFF	ON		30.31
ON	ON	OFF	OFF	OFF	OFF	OFF	ON	30.16
ON	ON	OFF	OFF	OFF	OFF	OFF	OFF	30.00
ON	OFF	ON	ON	ON	ON	ON	ON	29.85
ON	OFF	ON	ON	ON	ON	ON	OFF	29.69
ON	OFF	ON	ON	ON	ON	OFF	ON	29.54
ON	OFF	ON	ON	ON	ON	OFF	OFF	29.38
ON	OFF	ON	ON	ON	OFF	ON	ON	29.22
ON	OFF	ON	ON	ON	OFF	ON	OFF	29.06
ON	OFF	ON	ON	ON	OFF	OFF	ON	28.91
ON	OFF	ON	ON	ON	OFF	OFF	OFF	28.75
ON	OFF	ON	ON	OFF	ON	ON	ON	28.60
ON	OFF	ON	ON	OFF	ON	ON	OFF	28.44
ON	OFF	ON	ON	OFF	ON	OFF	ON	28.29
ON	OFF	ON	ON	OFF	ON	OFF	OFF	28.13
ON	OFF	ON	ON	OFF	OFF	ON	ON	27.97
ON	OFF	ON	ON	OFF	OFF	ON	OFF	27.81
ON	OFF	ON	ON	OFF	OFF	OFF	ON	27.66
ON	OFF	ON	ON	OFF	OFF	OFF	OFF	27.50
ON	OFF	ON	OFF	ON	ON	ON	ON	27.35
ON	OFF	ON	OFF	ON	ON	ON	OFF	27.19
ON	OFF	ON	OFF	ON	ON	OFF	ON	27.04
ON	OFF	ON	OFF	ON	ON	OFF	OFF	26.88
ON	OFF	ON	OFF	ON	OFF	ON	ON	26.72
ON	OFF	ON	OFF	ON	OFF	ON	OFF	26.56
ON	OFF	ON	OFF	ON	OFF	OFF	ON	26.41
ON	OFF	ON	OFF	ON	OFF	OFF	OFF	26.25
ON	OFF	ON	OFF	OFF	ON	ON	ON	26.10
ON	OFF	ON	OFF	OFF	ON	ON	OFF	25.94
ON	OFF	ON	OFF	OFF	ON	OFF	ON	25.79

ON = DIP Switch UP OFF = DIP Switch DOWN								
SW#9	SW#10	SW#11	SW#12	SW#13	SW#14	SW#15	SW#16	Gain
ON	OFF	ON	OFF	OFF	ON	OFF	OFF	25.63
ON	OFF	ON	OFF	OFF	OFF	ON	ON	25.47
ON	OFF	ON	OFF	OFF	OFF	ON	OFF	25.31
ON	OFF	ON	OFF	OFF	OFF	OFF	ON	25.16
ON	OFF	ON	OFF	OFF	OFF	OFF	OFF	25.00
ON	OFF	OFF	ON	ON	ON	ON	ON	24.85
ON	OFF	OFF	ON	ON	ON	ON	OFF	24.69
ON	OFF	OFF	ON	ON	ON	OFF	ON	24.54
ON	OFF	OFF	ON	ON	ON	OFF	OFF	24.38
ON	OFF	OFF	ON	ON	OFF	ON	ON	24.22
ON	OFF	OFF	ON	ON	OFF	ON	OFF	24.06
ON	OFF	OFF	ON	ON	OFF	OFF	ON	23.91
ON	OFF	OFF	ON	ON	OFF	OFF	OFF	23.75
ON	OFF	OFF	ON	OFF	ON	ON	ON	23.60
ON	OFF	OFF	ON	OFF	ON	ON	OFF	23.44
ON	OFF	OFF	ON	OFF	ON	OFF	ON	23.29
ON	OFF	OFF	ON	OFF	ON	OFF	OFF	23.13
ON	OFF	OFF	ON	OFF	OFF	ON	ON	22.97
ON	OFF	OFF	ON	OFF	OFF	ON	OFF	22.81
ON	OFF	OFF	ON	OFF	OFF	OFF	ON	22.66
ON	OFF	OFF	ON	OFF	OFF	OFF	OFF	22.50
ON	OFF	OFF	OFF	ON	ON	ON	ON	22.35
ON	OFF	OFF	OFF	ON	ON	ON		22.19
ON	OFF	OFF	OFF	ON	ON		ON	22.04
ON	OFF	OFF	OFF	ON	ON			21.88
ON	OFF	OFF	OFF	ON	OFF	ON	ON	21.72
ON	OFF	OFF	OFF	ON	OFF	ON		21.56
ON	OFF	OFF	OFF	ON	OFF	OFF	ON	21.41
ON	OFF	OFF	OFF	ON	OFF	OFF	OFF	21.25
ON	OFF	OFF	OFF	OFF	ON	ON	ON	21.10
ON	OFF	OFF	OFF	OFF	ON	ON		20.94
ON	OFF	OFF	OFF	OFF	ON		ON	20.79
ON	OFF	OFF	OFF	OFF	ON			20.63
ON	OFF	OFF	OFF	OFF	OFF	ON	ON	20.47
ON	OFF	OFF	OFF	OFF	OFF	ON		20.31
ON	OFF	OFF	OFF	OFF	OFF	OFF	ON	20.16
ON	OFF	OFF	OFF	OFF	OFF	OFF	OFF	20.00
OFF	ON	ON	ON	ON	ON	ON	ON	19.85
OFF	ON	ON	ON	ON	ON	ON	OFF	19.69
OFF	ON	ON	ON	ON	ON	OFF	ON	19.54
OFF	ON	ON	ON	ON	ON	OFF	OFF	19.38
OFF	ON	ON	ON	ON	OFF	ON	ON	19.22
OFF	ON	ON	ON	ON	OFF	ON	OFF	19.06
OFF	ON	ON	ON	ON	OFF	OFF	ON	18.91
OFF	ON	ON	ON	ON	OFF	OFF	OFF	18.75
OFF	ON	ON	ON	OFF	ON	ON	ON	18.60
OFF	ON	ON	ON	OFF	ON	ON	OFF	18.44
OFF	ON	ON	ON	OFF	ON	OFF	ON	18.29
OFF	ON	ON	ON	OFF	ON	OFF	OFF	18.13

ON = DIP Switch UP OFF = DIP Switch DOWN								
SW#9	SW#10	SW#11	SW#12	SW#13	SW#14	SW#15	SW#16	Gain
OFF	ON	ON	ON	OFF	OFF	ON	ON	17.97
OFF	ON	ON	ON	OFF	OFF	ON	OFF	17.81
OFF	ON	ON	ON	OFF	OFF	OFF	ON	17.66
OFF	ON	ON	ON	OFF	OFF	OFF	OFF	17.50
OFF	ON	ON	OFF	ON	ON	ON	ON	17.35
OFF	ON	ON	OFF	ON	ON	ON	OFF	17.19
OFF	ON	ON	OFF	ON	ON	OFF	ON	17.04
OFF	ON	ON	OFF	ON	ON	OFF	OFF	16.88
OFF	ON	ON	OFF	ON	OFF	ON	ON	16.72
OFF	ON	ON	OFF	ON	OFF	ON	OFF	16.56
OFF	ON	ON	OFF	ON	OFF	OFF	ON	16.41
OFF	ON	ON	OFF	ON	OFF	OFF	OFF	16.25
OFF	ON	ON	OFF	OFF	ON	ON	ON	16.10
OFF	ON	ON	OFF	OFF	ON	ON	OFF	15.94
OFF	ON	ON	OFF	OFF	ON	OFF	ON	15.79
OFF	ON	ON	OFF	OFF	ON	OFF	OFF	15.63
OFF	ON	ON	OFF	OFF	OFF	ON	ON	15.47
OFF	ON	ON	OFF	OFF	OFF	ON	OFF	15.31
OFF	ON	ON	OFF	OFF	OFF	OFF	ON	15.16
OFF	ON	ON	OFF	OFF	OFF	OFF	OFF	15.00
OFF	ON	OFF	ON	ON	ON	ON	ON	14.85
OFF	ON	OFF	ON	ON	ON	ON	OFF	14.69
OFF	ON	OFF	ON	ON	ON	OFF	ON	14.54
OFF	ON	OFF	ON	ON	ON	OFF	OFF	14.38
OFF	ON	OFF	ON	ON	OFF	ON	ON	14.22
OFF	ON	OFF	ON	ON	OFF	ON	OFF	14.06
OFF	ON	OFF	ON	ON	OFF	OFF	ON	13.91
OFF	ON	OFF	ON	ON	OFF	OFF	OFF	13.75
OFF	ON	OFF	ON	OFF	ON	ON	ON	13.60
OFF	ON	OFF	ON	OFF	ON	ON	OFF	13.44
OFF	ON	OFF	ON	OFF	ON	OFF	ON	13.29
OFF	ON	OFF	ON	OFF	ON	OFF	OFF	13.13
OFF	ON	OFF	ON	OFF	OFF	ON	ON	12.97
OFF	ON	OFF	ON	OFF	OFF	ON	OFF	12.81
OFF	ON	OFF	ON	OFF	OFF	OFF	ON	12.66
OFF	ON	OFF	ON	OFF	OFF	OFF	OFF	12.50
OFF	ON	OFF	ON	ON	ON	ON	ON	12.35
OFF	ON	OFF	OFF	ON	ON	ON	OFF	12.19
OFF	ON	OFF	OFF	ON	ON	OFF	ON	12.04
OFF	ON	OFF	OFF	ON	ON	OFF	OFF	11.88
OFF	ON	OFF	OFF	ON	OFF	ON	ON	11.72
OFF	ON	OFF	OFF	ON	OFF	ON	OFF	11.56
OFF	ON	OFF	OFF	ON	OFF	OFF	ON	11.41
OFF	ON	OFF	OFF	ON	OFF	OFF	OFF	11.25
OFF	ON	OFF	OFF	OFF	ON	ON	ON	11.10
OFF	ON	OFF	OFF	OFF	ON	ON	OFF	10.94
OFF	ON	OFF	OFF	OFF	ON	OFF	ON	10.79
OFF	ON	OFF	OFF	OFF	ON	OFF	OFF	10.63
OFF	ON	OFF	OFF	OFF	OFF	ON	ON	10.47

ON = DIP Switch UP OFF = DIP Switch DOWN								
SW#9	SW#10	SW#11	SW#12	SW#13	SW#14	SW#15	SW#16	Gain
OFF	ON	OFF	OFF	OFF	OFF	ON	OFF	10.31
OFF	ON	OFF	OFF	OFF	OFF	OFF	ON	10.16
OFF	ON	OFF	OFF	OFF	OFF	OFF	OFF	10.00
OFF	OFF	ON	ON	ON	ON	ON	ON	9.85
OFF	OFF	ON	ON	ON	ON	ON	OFF	9.69
OFF	OFF	ON	ON	ON	ON	OFF	ON	9.54
OFF	OFF	ON	ON	ON	ON	OFF	OFF	9.38
OFF	OFF	ON	ON	ON	OFF	ON	ON	9.22
OFF	OFF	ON	ON	ON	OFF	ON	OFF	9.06
OFF	OFF	ON	ON	ON	OFF	OFF	ON	8.91
OFF	OFF	ON	ON	ON	OFF	OFF	OFF	8.75
OFF	OFF	ON	ON	OFF	ON	ON	ON	8.60
OFF	OFF	ON	ON	OFF	ON	ON	OFF	8.44
OFF	OFF	ON	ON	OFF	ON	OFF	ON	8.29
OFF	OFF	ON	ON	OFF	ON	OFF	OFF	8.13
OFF	OFF	ON	ON	OFF	OFF	ON	ON	7.97
OFF	OFF	ON	ON	OFF	OFF	ON	OFF	7.81
OFF	OFF	ON	ON	OFF	OFF	OFF	ON	7.66
OFF	OFF	ON	ON	OFF	OFF	OFF	OFF	7.50
OFF	OFF	ON	OFF	ON	ON	ON	ON	7.35
OFF	OFF	ON	OFF	ON	ON	ON	OFF	7.19
OFF	OFF	ON	OFF	ON	ON	OFF	ON	7.04
OFF	OFF	ON	OFF	ON	ON	OFF	OFF	6.88
OFF	OFF	ON	OFF	ON	OFF	ON	ON	6.72
OFF	OFF	ON	OFF	ON	OFF	ON	OFF	6.56
OFF	OFF	ON	OFF	ON	OFF	OFF	ON	6.41
OFF	OFF	ON	OFF	ON	OFF	OFF	OFF	6.25
OFF	OFF	ON	OFF	OFF	ON	ON	ON	6.10
OFF	OFF	ON	OFF	OFF	ON	ON	OFF	5.94
OFF	OFF	ON	OFF	OFF	ON	OFF	ON	5.79
OFF	OFF	ON	OFF	OFF	ON	OFF	OFF	5.63
OFF	OFF	ON	OFF	OFF	OFF	ON	ON	5.47
OFF	OFF	ON	OFF	OFF	OFF	ON	OFF	5.31
OFF	OFF	ON	OFF	OFF	OFF	OFF	ON	5.16
OFF	OFF	ON	OFF	OFF	OFF	OFF	OFF	5.00
OFF	OFF	OFF	ON	ON	ON	ON	ON	4.85
OFF	OFF	OFF	ON	ON	ON	ON	OFF	4.69
OFF	OFF	OFF	ON	ON	ON	OFF	ON	4.54
OFF	OFF	OFF	ON	ON	ON	OFF	OFF	4.38
OFF	OFF	OFF	ON	ON	OFF	ON	ON	4.22
OFF	OFF	OFF	ON	ON	OFF	ON	OFF	4.06
OFF	OFF	OFF	ON	ON	OFF	OFF	ON	3.91
OFF	OFF	OFF	ON	ON	OFF	OFF	OFF	3.75
OFF	OFF	OFF	ON	OFF	ON	ON	ON	3.60
OFF	OFF	OFF	ON	OFF	ON	ON	OFF	3.44
OFF	OFF	OFF	ON	OFF	ON	OFF	ON	3.29
OFF	OFF	OFF	ON	OFF	ON	OFF	OFF	3.13
OFF	OFF	OFF	ON	OFF	OFF	ON	ON	2.97
OFF	OFF	OFF	ON	OFF	OFF	ON	OFF	2.81

ON = DIP Switch UP OFF = DIP Switch DOWN								
SW#9	SW#10	SW#11	SW#12	SW#13	SW#14	SW#15	SW#16	Gain
OFF	OFF	OFF	ON	OFF	OFF	OFF	ON	2.66
OFF	OFF	OFF	ON	OFF	OFF	OFF	OFF	2.50
OFF	OFF	OFF	OFF	ON	ON	ON	ON	2.35
OFF	OFF	OFF	OFF	ON	ON	ON	OFF	2.19
OFF	OFF	OFF	OFF	ON	ON	OFF	ON	2.04
OFF	OFF	OFF	OFF	ON	ON	OFF	OFF	1.88
OFF	OFF	OFF	OFF	ON	OFF	ON	ON	1.72
OFF	OFF	OFF	OFF	ON	OFF	ON	OFF	1.56
OFF	OFF	OFF	OFF	ON	OFF	OFF	ON	1.41
OFF	OFF	OFF	OFF	ON	OFF	OFF	OFF	1.25
OFF	OFF	OFF	OFF	OFF	ON	ON	ON	1.10
OFF	OFF	OFF	OFF	OFF	ON	ON	OFF	0.94
OFF	OFF	OFF	OFF	OFF	ON	OFF	ON	0.79
OFF	OFF	OFF	OFF	OFF	ON	OFF	OFF	0.63
OFF	OFF	OFF	OFF	OFF	OFF	ON	ON	0.47
OFF	OFF	OFF	OFF	OFF	OFF	ON	OFF	0.31
OFF	OFF	OFF	OFF	OFF	OFF	OFF	ON	0.16
OFF	OFF	OFF	OFF	OFF	OFF	OFF	OFF	0