

# AETECHRON



# DSR 100-25

## Dropout, Surge, Ripple Simulator and AC/DC Voltage Source

*Operation Manual*

---

574.295.9495 | [www.aetechron.com](http://www.aetechron.com)  
2507 Warren Street, Elkhart, IN 46516

## Three-Year, No-Fault Warranty

### SUMMARY OF WARRANTY

**AE TECHRON INC.**, of Elkhart, Indiana (Warrantor) warrants to you, the ORIGINAL COMMERCIAL PURCHASER and ANY SUBSEQUENT OWNER of each NEW **AE TECHRON INC. product, for a period of three (3) years from the date of purchase, by the original purchaser (warranty period) that the product is free of defects in materials and workmanship and will meet or exceed all advertised specifications for such a product. We further warrant the new AE Techron product regardless of the reason for failure, except as excluded in the Warranty.**

### ITEMS EXCLUDED FROM WARRANTY

This AE Techron Warranty is in effect only for failure of a new AE Techron product which occurred within the Warranty Period. It does not cover any product which has been damaged because of any intentional misuse, or loss which is covered under any of your insurance contracts. This warranty does not extend to any product on which the serial number has been defaced, altered, or removed. It does not cover damage to loads or any other products or accessories resulting from **AE TECHRON INC.** product failure. It does not cover defects or damage caused by the use of unauthorized modifications, accessories, parts, or service.

### WHAT WE WILL DO

We will remedy any defect, regardless of the reason for failure (except as excluded), by repair or replacement, at our sole discretion. Warranty work can only be performed at our authorized service centers or at our factory.

Expenses in remedying the defect will be borne by **AE TECHRON INC.**, including one-way surface freight shipping costs within the United States. (Purchaser must bear the expense of shipping the product between any foreign country and the port of entry in the United States and all taxes, duties, and other customs fees for such foreign shipments.)

### HOW TO OBTAIN WARRANTY SERVICE

When you notify us or one of our authorized service centers of your need for warranty service, you will receive an authorization to return the product for service. All components must be shipped in a factory pack or equivalent which, if needed, may be obtained

from us for a nominal charge. We will take corrective actions and return the product to you within three weeks of the date of receipt of the defective product, or will make available to you a product of equal or better performance on temporary loan until your product can be repaired or replaced and returned to you. If the repairs made by us are not satisfactory, notify us immediately.

### DISCLAIMER OF CONSEQUENTIAL AND INCIDENTAL DAMAGES

You are not entitled to recover from us any consequential or incidental damages resulting from any defect in our product. This includes any damage to another product or products resulting from such a defect.

### WARRANTY ALTERATIONS

No person has the authority to enlarge, amend, or modify this warranty. The warranty is not extended by the length of time for which you are deprived of the use of this product. Repairs and replacement parts provided under the terms of this warranty shall carry only the unexpired portion of this warranty.

### DESIGN CHANGES

We reserve the right to change the design of any product from time to time without notice and with no obligation to make corresponding changes in products previously manufactured.

### LEGAL REMEDIES OF PURCHASER

There is no warranty that extends beyond the terms hereof. This written warranty is given in lieu of any oral or implied warranties not contained herein. We disclaim all implied warranties, including, without limitation, any warranties of merchantability or fitness for a particular purpose. No action to enforce this Warranty shall be commenced later than ninety (90) days after expiration of the warranty period. This statement of warranty supersedes any others contained in this manual for AE Techron products.

### **AE TECHRON INC.** **Customer Service Department**

2507 Warren St. Elkhart, IN, 46516, U.S.A.  
(574) 295-9495  
[www.aetechron.com](http://www.aetechron.com)

# Contents

1	About the DSR 100-25 Test System .....	5
1.1	Features .....	5
1.2	Disclaimer.....	5
2	System Setup.....	6
2.1	Safety First.....	6
2.2	Unpacking and Installing .....	6
2.3	Configuration Options.....	6
2.4	Connections .....	7
2.5	Startup Procedure .....	8
2.6	Shutdown Procedure.....	8
3	Operation .....	10
3.1	System Controls and Connectors.....	10
3.2	3110A Operation.....	11
3.3	Amplifier Module Operation .....	12
4	Applications.....	15
4.1	Configure for Low-Voltage Testing .....	15
4.2	Using an External Signal Source.....	16
4.3	Using an External Amplifier .....	17
5	Maintenance .....	19
5.1	Clean Filter and Grill on Amplifier Module.....	19
6	Troubleshooting .....	20
6.1	Factory Service: .....	21





Figure 1.1 – DSR 100-25 System

## 1 About the DSR 100-25 Test System

Congratulations on your purchase of an AE Techron DSR 100-25 test system, designed for use in EMC testing as a dropout, surge, ripple simulator and AC/DC voltage source. A DSR 100-25 test system provides a complete, single-box solution for immunity testing. It includes a simple-to-use yet powerful 3110A Standards Waveform Generator matched with an industry leading power supply technology and comes with an extensive library of tests for many automotive and aviation standards.\*

The DSR 100-25 is 4-quadrant, allowing it to source and sink current. It has power in reserve; it is able to provide 4X rated power for in-rush testing up to 200 ms, as is required in DO 160 Section 16.

The AE Techron brand is known throughout the world for its robust precision amplifiers and test systems as well as its product service and support.

**\*Some Standards' tests included in the 3110A Library may require voltages above the maximum voltage available in your DSR 100-25 system. To run those tests, connect the 3110A to a different amplifier or amplifier system that can generate the required voltage.**

### 1.1 Features

- Includes a library of 3000+ pre-entered Automotive and Aviation Standards' test routines
- Operate as a free-standing system using the included monitor, keyboard and mouse, or control via LAN
- Very easy to modify existing tests or build new test sequences
- Can function as a controller or node in a larger test system via built-in LAN and GPIO controls

### 1.2 Disclaimer

Although AE Techron has made substantial effort to ensure the accuracy of the Standards' test files (SWG files), which are included with the DSR 100-series cabinet, no warranty, expressed or implied, is made regarding accuracy, adequacy, completeness, legality, reliability or usefulness of the information provided. It is the responsibility of the user to ensure the accuracy and applicability of these test files for their intended purposes.

## 2 System Setup

### 2.1 Safety First

Throughout these instructions, special emphasis is placed on good safety practices. The following graphics are used to highlight certain topics that require extra precaution.



### 2.2 Unpacking and Installing

Carefully unpack the DSR 100-25 and accessories from the two cartons and visually inspect the contents for damage. All units are tested and inspected for damage before leaving the factory, so if any damage is found, please notify the shipping company immediately. Save the shipping cartons and materials as evidence of damage.

#### 2.2.1 Check Contents

In addition to the DSR 100-25 system, your shipment should include the following:

1. LCD monitor
2. Monitor power cord
3. HDMI-to-DVI monitor cable
4. USB mouse
5. USB keyboard
6. Mating Supercon connectors (2)
7. Ethernet cable
8. Mouse pad
9. System power cord
10. Quick Start Guide
11. DSR 100-25 Operation Manual on USB drive

#### 2.2.2 DSR System Location

The DSR 100-25's case features heavy-duty handles to allow the user to move the system from bench-top to bench-top. Locate the system near a 120V, 20AAC supply,

#### 2.3 Configuration Options

Your DSR 100-25 system includes an integrated 3110A Standards Waveform Generator that contains an extensive library of tests for many automotive, aviation, and industry standards. The 3110A provides a powerful yet simple-to-use interface to help streamline the testing process. 3110A test files (.swg) are easy to link, build from scratch, or customize using time-saving controls like triggers and loops with changing variables. Plus, the 3110A's intuitive, drag-and-drop interface makes it easy to modify existing tests or build new tests.

The 3110A can produce standard signals and waveforms with or without a DC offset. Frequency, amplitude and DC offset can be fixed or swept, and sinewave sweeps can be linear, logarithmic or exponential. It can create dropouts and surges and can also produce ripple waveforms of up to 1 MHz

As it ships from the factory, the DSR 100-25 is capable of performing thousands of different EMC immunity tests. However, in order to meet some test requirements, changes to the DSR system's configuration may be needed.

These alternative configurations include:

**Low-Voltage Testing:** Standards Tests having a maximum voltage of less than 30V may require an increase in the signal-to-noise performance of the DSR 100-25 system in order to achieve accurate results.

**External Signal Source:** The DSR 100-25 system can be configured to use an external signal source in place of the internal 3110A signal generator,

**External 7000 Series Amplifier:** The DSR 100-25 system can be configured to use an external AE Techron 7000 Series amplifier in place of the internal amplifier.

The settings and connections required for these special uses are detailed in the **Applications** section of this manual.

**2.4 Connections**

Make the following connections to prepare the DSR 100-25 system for standard operation.

**2.4.1 Connect Signal Input**

Using a standard BNC cable, connect from the Signal Out BNC connector located on the front panel of the 3110A to the Aux Input BNC connector located on the DSR 100-25's I/O panel. See **Figure 2.1**.

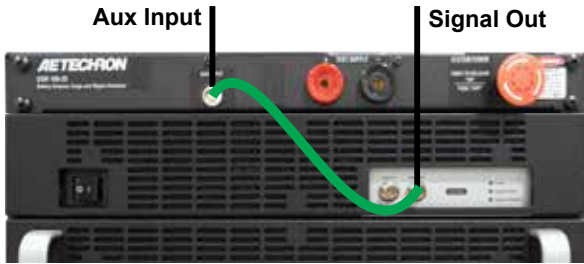

Figure 2.1 – Signal Input Connections

**2.4.2 Connect to the Device Under Test**

Make sure the DSR 100-25 system is turned off and AC power is disconnected. Using the supplied mating output connectors and wiring appropriate for your application, connect from the DSR 100-25

**! WARNING**

**ELECTRIC SHOCK HAZARD.**

Output potentials can be lethal. Make connections only with AC Power unplugged or switched off at the source and the system's AC power switch in the OFF position.

system's front-panel positive and negative Test Supply connectors to the device under test. See **Figure 2.2**.



Figure 2.2 – Test Supply Connectors

**2.4.3 Connect the 3110 Accessories**

Complete the following steps to connect the 3110A cables and accessories provided to the DSR 100-25 back panel. Refer to **Figure 2.3** for component locations.

- A. Plug the USB keyboard into the USB port labeled KEYBOARD on the DSR 100-25 back panel.

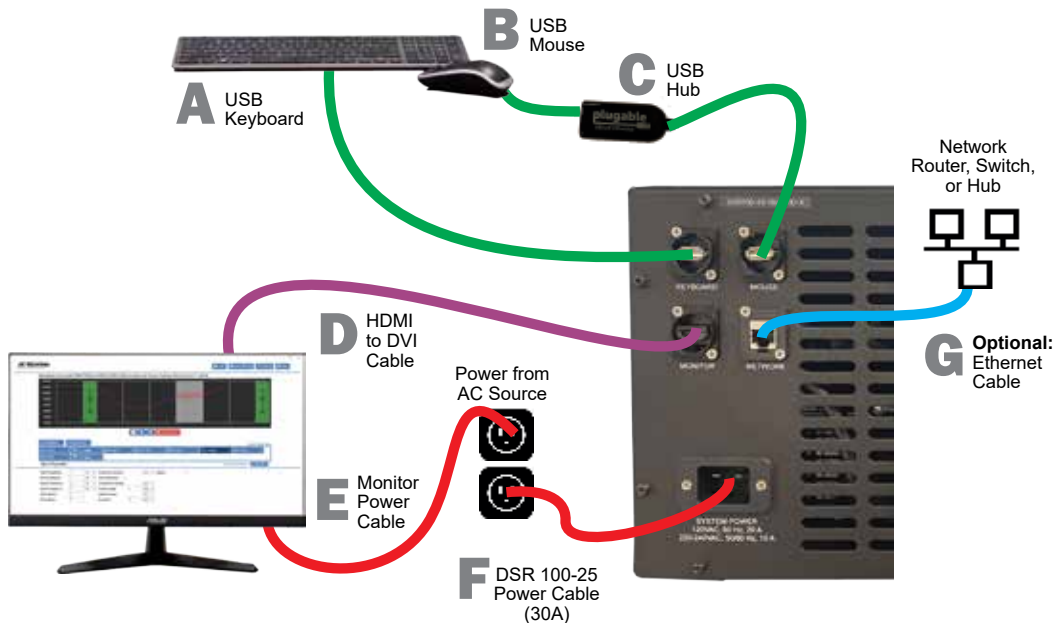

Figure 2.3 – Connecting the 3110A Cables and Accessories on the DSR 100-25

- F. Plug the DSR 100-25 power cord into the power connector located on the DSR 100-25 back panel, and then connect the cord to a 20A power source.
- G. **OPTIONAL:** To connect the DSR 100-25 to be accessed and controlled through a network: Plug the Ethernet cable to the Ethernet port labeled NETWORK, and then plug the Ethernet cable into a router, switch or hub on the network. Refer to the topic “Remote Operation” in the **3110A Help** files for more information.

**Note on Network Control of the 3110A:** After network control of the 3110A has been implemented, the monitor, keyboard and mouse can be disconnected from the 3110A and the system can be operated remotely. See the topic “Remote Operation” in the **3110A Help** files for more information.

**2.5 Startup Procedure**

Complete the following steps to power up the DSR system.

1. Use the monitor’s power switch (last button on the right) to turn on the monitor.
2. Check the power/breaker switch on the 3110A and the amplifier module. Make sure both units are switched ON. See **Figure 2.4**.
3. Check the amplifier modules’s gain control and make sure it is fully clockwise. See **Figure 2.5**.
4. Twist the SYSTEM POWER switch to turn the DSR system ON. See **Figure 2.6**.
5. Wait for the 3110A interface to load (loading will take up to 30 seconds). Press the Help button to access this manual from within the program.
6. Run the System Calibration test to determine the proper settings for your system. Note that the default system gain for the DSR 100-25 will be 10. See the “**Calibration**” section in the **3110A Help** files for more information.

**2.6 Shutdown Procedure**

**IMPORTANT: Any powered amplifiers (Including the integrated amplifier module or any external amplifiers) that are connected to the**

**3110 Standards Waveform Generator**

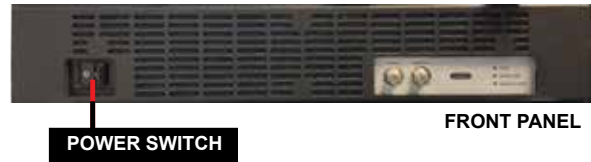

**Amplifier Module**



Figure 2.4 – Locations of Power/Breaker Switches for System Modules

**Amplifier Module**



Figure 2.5 – Gain Control Location



Figure 2.6 – System Power Switch Location

**3110A must first be disabled before shutting down the 3110A or DSR 100-25 System.** Failure to follow the proper shutdown procedure can result in damage to the amplifiers or any connected load/ DUT.

Complete the following to safely shut down a 3110/ amplifier combination or DSR System:

1. Make sure any amplifiers connected to the system are disabled, including the integrated amplifier module in the DSR system and/or

any connected external amplifiers or amplifier systems. You can turn the integrated amplifier module off by using the module's power switch. See **Figure 2.4** for power switch location.

To quickly disable external AE Techron 7000 series amplifiers, press the Stop button on the front panel of the amplifier or on any amplifier

in an amplifier system to place all connected units in Standby mode.

2. After all amplifiers have been disabled, turn the system OFF by pressing the System Power button.

**NOTE:** If the 3110A is not connected to any amplifiers, it can be safely shut down by simply pressing the 3110A front-panel power switch.

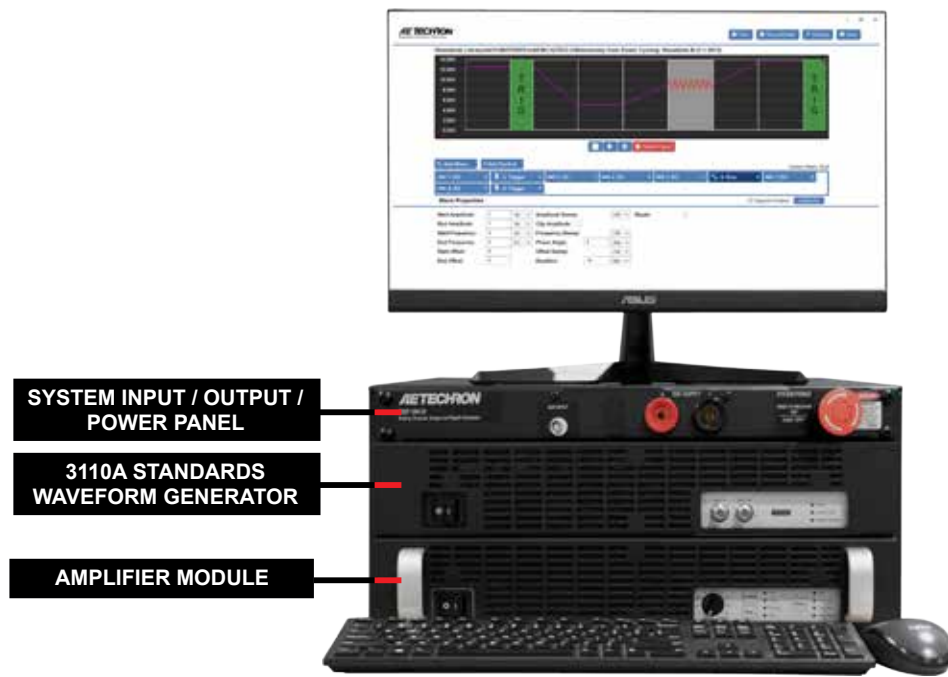

Figure 3.1 – DSR 100-25 Module Locations

### 3 Operation

**IMPORTANT:** Before operating the DSR 100-25 system, the **3110A System Calibration Procedures** should be performed to verify the correct System Gain and DC Offset settings for your system. See the topic “System Calibration” in the **3110A Help** files for more information.

#### System Overview

Your DSR 100-25 system provides one integrated signal generation device to produce the test sequences, and one amplifier module to reproduce and amplify the output signal. The location of each module is specified in **Figure 3.1**.

#### 3.1 System Controls and Connectors

System level controls and connectors are located on the Input/Output/Power panel installed at the

top front of the unit. Refer to **Figure 3.2** for component locations.

**Aux Input:** An unbalanced BNC connector is used to provide the input signal to the DSR 100-25 system from the 3110A or an external signal generator.

**Test Supply (System Output):** A pair of high-current connectors are provided to supply the test signal to the DUT. Connector type, either Anderson or Supercon, must be specified when ordering. Mating connectors are provided with the unit.

**System Power:** A power/emergency stop switch is provided which controls the power supply to the system and all system components. Turn clockwise to power the system on. Press in to power off the system.

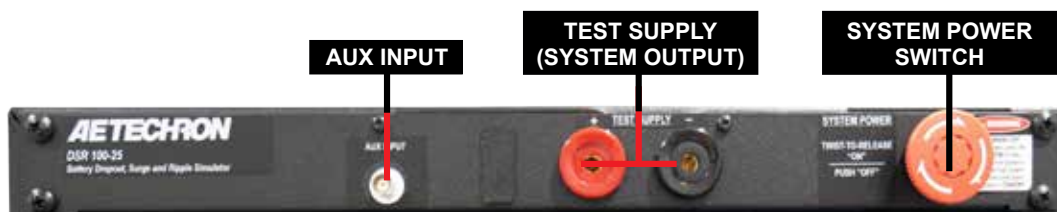

Figure 3.2 – DSR 100-25 System Controls and Connectors

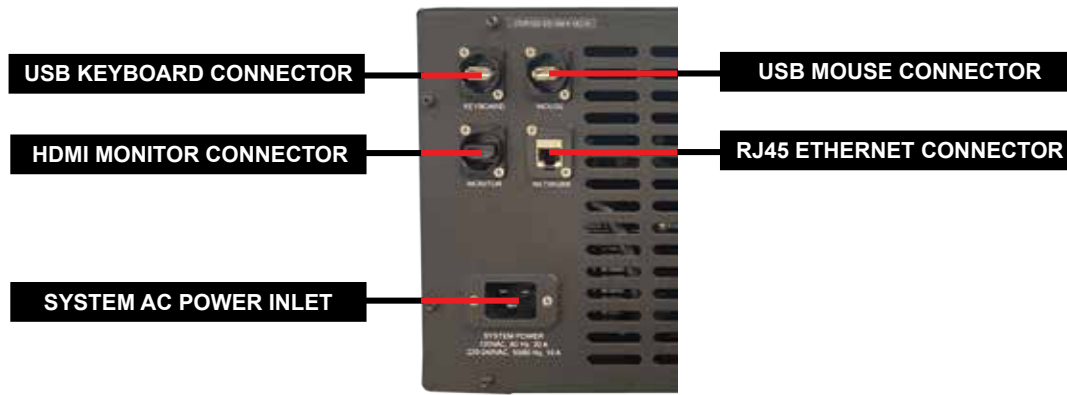

Figure 3.3 – Back-Panel Connectors for System Power and 3110A Accessories

### 3.2 3110A Operation

The AE Techron 3110A Standards Waveform Generator provides an intuitive interface for waveform sequence creation and generation. The following sections describe the 3110A connection and operation.

#### 3.2.1 3110A Accessories

The accessories required for operation of the 3110A are connected using the Accessories panel located on the cabinet rear. Refer to **Figure 3.3** for connector locations.

#### 3.2.2 3110A Front-Panel Controls, Connectors, and Indicators

See **Figure 3.4** for item locations.

**Power Switch:** The Power switch controls the AC mains power to the 3110A. Switch to the ON position (I) to turn the 3110A on. Switch to the OFF position (O) to turn the 3110A off..

**Signal In (Diagnostics Port):** An unbalanced BNC connector is available for diagnostic use by Factory Service..

**Signal Out:** An unbalanced BNC connector is used to provide the signal from the 3110A to an external amplifier.

**Power Indicator:** The LED will light when the 3110A has AC power and is ready for operation.

**System Fault Indicator:** The LED will light if a fault condition occurs in the 3110A system.

**Signal In Enabled:** The LED will light when diagnostic equipment connected to the 3110A's Signal In Port and enabled.

#### 3.2.3 3110A Software Basic Operation

To select a pre-programmed test from the Standard's Library, simply use the Files button to open the files window and select the test file. Refer to **Figure 3.5** for on-screen controls' locations.

Custom test files can be created by adding waveforms and controls to the test sequence display. For help in getting up and running quickly on the 3110A, please see the "3110A Tutorials" section in the **3110A Help** files.

Please also refer to the **3110A Help** files for general operation and troubleshooting information, The **Help** files are available by selecting the Help button from the 3110A main window. They are also provided in pdf format on the USB drive shipped with your DSR 100 system, or on the AE Techron website at aetechron.com.

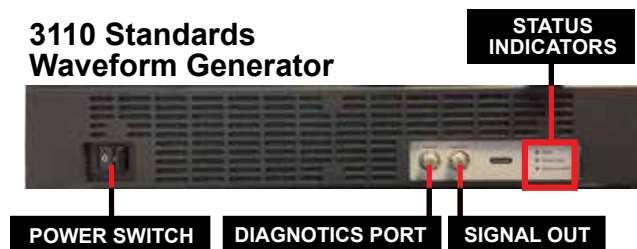

Figure 3.4 – 3110A Front-Panel Controls, Connectors, and Indicators

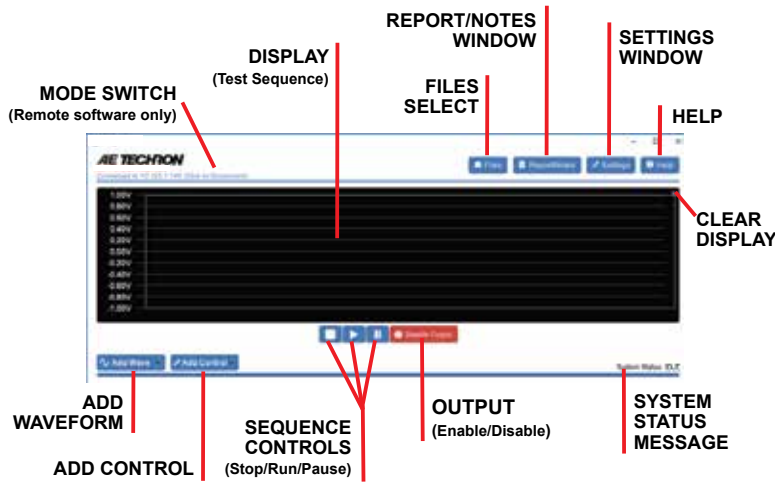

Figure 3.5 – AE Techron 3110A On-screen Controls

### 3.3 Amplifier Module Operation

Your DSR system contains one amplifier module to provide the high-current output required for many Standards' tests. The following sections describe the controls and indicators found on the DSR 100-25 amplifier module.

#### 3.3.1 Front-Panel Controls

See **Figure 3.6** for item locations.

**Power/Breaker Switch** - The Power/Breaker Switch controls the AC mains power to the amplifier module. Switch to the ON position (I) to turn the module on. Switch to the OFF position (O) to turn the module off.

The Power/Breaker Switch also serves as a Breaker. When the Breaker is tripped, this switch moves to a neutral position between ON and OFF. To reset the Breaker, turn the Power/Breaker Switch OFF (O) and then turn it back ON (I).

**Gain Control** - The Gain Control knob increases/decreases the gain from 0 – 100% of the overall Gain. Turn the Gain Control fully clockwise for maximum output from the amplifier module.

#### Input Buttons

Three push buttons on the amplifier module's front panel control basic operation of the module.

**Enable** – Enable will release the amplifier module from Stop mode and place it in Run mode (both

Ready and Run LEDs will be lit). When the amplifier module is placed in Run mode, the high-voltage transformers will be energized and the module will amplify the input signal.

**Stop** – Stop will place the amplifier module in Stop mode (both Standby and Stop LEDs will be lit). When an amplifier module is in Stop mode, the low-voltage transformer is energized but the high-voltage transformers are not.

**Reset** – When a fault condition occurs, the amplifier module may be placed in Standby mode (Standby LED will be lit), depending on the fault condition. To release the module from Standby mode, clear the fault condition and then press the Reset button. If the amplifier module is in Run mode when the fault condition occurs, pressing the Reset button will return the module to Run mode. If the amplifier module is in Stop mode when the fault condition occurs, pressing the Reset button will return the module to Stop mode.

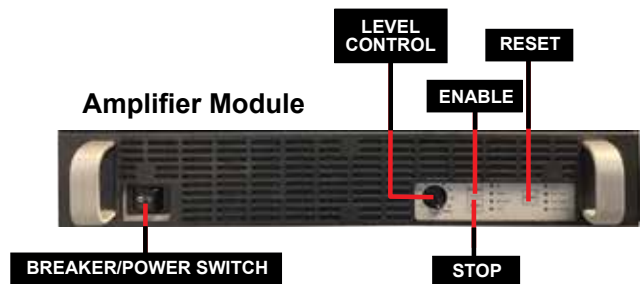

Figure 3.6 – Amplifier Module Controls



Figure 3.7 – Amplifier Module Status Indicators

### 3.3.2 Front-Panel Status Indicators

Please refer to **Figure 3.7** for item locations.

### Main Status Indicators

Four Main Status indicators are located on the amplifier module’s front-panel. These LEDs monitor the internal conditions of the module and indicate the current state of operation. The chart in **Figure 3.8** details the operational modes indicated by the Main Status indicators.

**Figure 3.8 – Main Status Indicators**

● ● ● Indicator is lit   ● Indicator is not lit   ○ Indicator may be lit

Main Status Indicators	State of Operation	Action Needed to Return to Run Mode
● Run ● Ready ● Standby ● Stop	<b>Run mode:</b> The amplifier module’s high-voltage transformers are energized and the unit will amplify the input signal. Run mode is initiated by: (1) the Enable push button when the amplifier module is in Standby mode, or (2) when the amplifier module powers up..	N/A
● Run ○ Ready ● Standby ● Stop	<b>Standby mode:</b> Standby mode indicates that the amplifier module is functioning properly and all Fault Status modes are clear, but it is being held in Standby by an external condition. The amplifier module will enter Standby mode briefly after powering up, and then will move automatically into Run mode. In Standby mode, the amplifier module’s low-voltage transformer is energized but the high-voltage transformers are not.	If the amplifier module remains in Standby mode, it may require servicing. Please contact AE Techron Technical Support.
● Run ● Ready ● Standby ● Stop	<b>Stop mode:</b> When the Stop button on the amplifier front panel is pressed, the amplifier will enter Stop mode. In Stop mode, the amplifier’s low-voltage transformer is energized but the high-voltage transformers are not.	To release the amplifier from Stop mode, press the Enable button.

### Fault Status Indicators

Four Fault Status indicators are located on the amplifier module’s front panel. These LEDs monitor the internal conditions of the module and will illuminate when a fault condition occurs. Depending on the fault condition, the DSR 100-25 system

may be placed in Standby mode when a fault condition occurs. Refer to the chart in **Figure 3.9** to determine the fault condition being indicated and the action required to clear the fault condition.

**Figure 3.9 – Fault Status Indicators**

● ● ● Indicator is lit   ● Indicator is not lit   ○ Indicator may be lit

Main Status Indicators	Fault Status Indicators	State of Operation	Action Needed to Clear Fault Condition and Return to Run Mode
● Run ● Ready ● Standby ● Stop	● Fault ● Over Load ● Over Temp ● Over Voltage	<b>Output Fault status:</b> This indicates that an Output Fault condition has occurred and the amplifier module has been placed in Standby mode. The Fault indicator will light under two conditions: 1) High-frequency oscillation is causing high shoot-through current; or 2) An output transistor has shorted, causing the output fault condition.	This fault condition cannot be cleared using the front-panel Reset button. See the <b>Troubleshooting</b> section for more information on diagnosing and clearing this fault condition.

<b>Main Status Indicators</b>	<b>Fault Status Indicators</b>	<b>State of Operation</b>	<b>Action Needed to Clear Fault Condition and Return to Run Mode</b>
<ul style="list-style-type: none"> <li>● Run</li> <li>● Ready</li> <li>○ Standby</li> <li>● Stop</li> </ul>	<ul style="list-style-type: none"> <li>● Fault</li> <li>● Over Load</li> <li>● Over Temp</li> <li>● Over Voltage</li> </ul>	<p><b>Over Load status:</b> This indicates that the output of the dsr 100-25 system could not follow the input signal due to voltage or current limits. Under normal operation with the factory-default settings, an Over Load condition will not place the amplifier module in Standby mode.</p>	<p>To remedy the Over Load fault during operation, turn down the level of the input signal until the Over Load indicator turns off.</p>
<ul style="list-style-type: none"> <li>● Run</li> <li>● Ready</li> <li>● Standby</li> <li>● Stop</li> </ul>	<ul style="list-style-type: none"> <li>● Fault</li> <li>● Over Load</li> <li>○ Over Temp</li> <li>● Over Voltage</li> </ul>	<p><b>Over Temp status:</b> The system monitors the temperature inside the amplifier module's high-voltage transformers, low-voltage transformer and in the output stage heat sinks. The Over Temp indicator will light and the amplifier module will be placed in Standby mode when the temperature sensors detect a condition that would damage the module. If the Over Temp pulse is extremely short, as in the case of defective wiring or switches, the Over Temp LED may be lit too briefly to observe.</p>	<p>To reset after an Over Temp fault has occurred, make sure the fans are running in the amplifier module, and then remove the input signal from the amplifier module. Allow the fans to run for about 5 to 15 minutes, and then push and hold the Reset button until the Standby LED turns off. Release the Reset button to return the system to Run mode. See the <b>Troubleshooting</b> section for information on correcting the cause of an Over Temp fault condition.</p>
<ul style="list-style-type: none"> <li>● Run</li> <li>● Ready</li> <li>● Standby</li> <li>● Stop</li> </ul>	<ul style="list-style-type: none"> <li>● Fault</li> <li>● Over Load</li> <li>● Over Temp</li> <li>● Over Voltage</li> </ul>	<p><b>Over Voltage status:</b> This indicates that the AC mains voltage is more than +10% of nominal. The amplifier module will be forced to Standby when an Over Voltage condition occurs. When the Over Voltage condition is cleared, the module will automatically return to Run mode.</p>	<p>To clear an Over Voltage fault condition, the AC mains must be brought down to the nominal value. Once the Over Voltage condition has been cleared, press the Reset button to return the amplifier module to Run mode. If the module does not return to Run mode, it may require servicing. Please see the <b>Troubleshooting</b> section for more information.</p>

## 4 Applications

The DSR 100-25 has been configured at the factory for use as a general-purpose system capable of generating the test signal for a wide range of Standards' testing.

When the **default** configuration is used, the 3110A controller in the DSR system will produce the test waveform and the amplifier module in the DSR system will amplify the test signal.

Three additional configurations are detailed in this manual:

**Low-Voltage Testing:** Standards Tests having a maximum voltage of less than 30V may require an increase in the signal-to-noise performance of the DSR 100 system in order to achieve accurate results.

**External Signal Source:** The DSR 100-25 system can be configured to use an external signal source in place of the internal 3110A signal generator,

**External Amplifier:** The DSR 100-25 system can be configured to use an external amplifier in place of the internal amplifier. Note that the amplifier should be an AE Techron 7000 Series or equivalent.

Each alternate use requires different setup and startup procedures. Please refer to the following instructions to setup and operate the DSR 100-25 system according to your requirements.

### 4.1 Configure for Low-Voltage Testing

Standards Tests having a maximum voltage of less than 30V may require an increase in the signal-to-noise performance of the DSR 100-25 system in order to achieve accurate results. This can be achieved by lowering the DSR 100-25's gain. Only a few test sequences will require use of this configuration. **NOTE: When using this configuration, the DSR 100-25's system gain will be 6.**

#### 4.1.1 Setup Procedure

Complete the following steps to configure and connect the DSR 100-25 system and other required equipment.

#### 1. Adjust the Amplifier Module's DIP Switch

**Setting:** Open the system's access door located on the back of the unit. Find the bank of eight (8) DIP switches located on the amplifier module's back panel. See **Figure 4.1**.

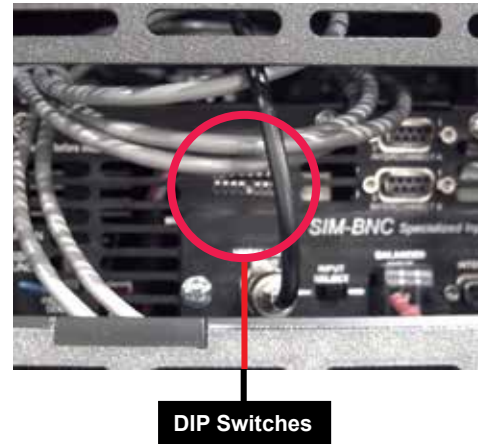

Figure 4.1 – Location of Amplifier Module's DIP Switches

Move DIP switch #4 to the DOWN position. (Note: DIP switches are numbered from left to right).

#### 2. Connect 3110A Accessories:

If not already connected, follow the instructions in the **System Setup** section of this manual to connect the 3110A accessories.

#### 3. Connect the Signal Source:

Using a standard BNC cable, connect from the Signal Out BNC connector located on the front panel of the 3110A to the Aux Input BNC connector located on the DSR 100-25's I/O panel. See **Figure 4.2**.

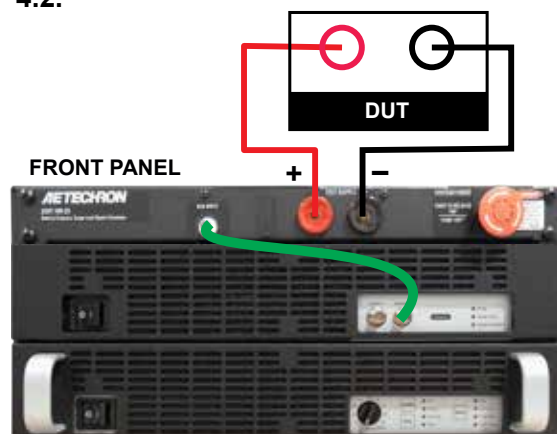

Figure 4.2 – Connections for Low-Voltage Testing



Figure 4.3 – Locations of Controls for Low-Voltage Testing

4. **Connect the Outputs:** Using the supplied mating output connectors and wiring appropriate for your application, connect from the DSR 100-25's positive and negative test supply connectors to the device under test. See **Figure 4.2**.

**4.1.2 Startup Procedure:**

Complete the following to enable the DSR 100-25 system: Refer to **Figure 4.3** for control locations.

1. Make sure the breaker/power switch on the amplifier module is in the ON position.
2. Make sure the power switch on the 3110A controller is in the ON position.
3. Make sure the Gain control on the amplifier module is fully clockwise.
4. Twist the System Power switch clockwise to turn the DSR system ON.

**4.2 Using an External Signal Source**

This application uses an external signal source and the DSR system's internal amplifier. **NOTE: When using this configuration, the DSR 100-25's system gain will be 20.**

**4.2.1 Setup Procedure**

Complete the following steps to connect the DSR 100-25 system and other required equipment.

1. **Connect 3110A Accessories:** If not already connected, follow the instructions in the **System Setup** section of this manual to connect the 3110A accessories.

2. **Connect the Signal Source:** Use a BNC cable to connect from the signal output connector on your external signal source to the DSR100-25's BNC connector labeled Aux Input. See **Figure 4.4**.
3. **Connect the Outputs:** Using the supplied mating output connectors and wiring appropriate for your application, connect from the DSR 100-25's positive and negative test supply connectors to the device under test. See **Figure 4.4**.

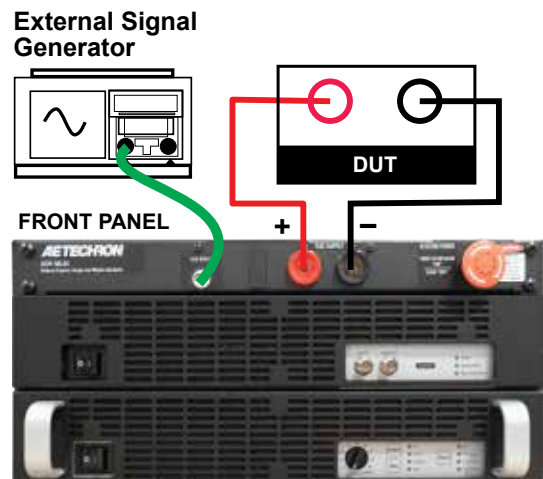

Figure 4.4 – Connecting an External Signal Source

**4.2.2 Startup Procedure:**

Complete the following to enable the DSR 100-25 system: Refer to **Figure 4.5** for control locations.



Figure 4.5 – Locations of Controls for Operation with an External Signal Source

1. Make sure the breaker/power switch on the amplifier module is in the ON position.
2. Make sure the power switch on the 3110A controller is in the OFF position.
3. Make sure the Gain control on the amplifier module is fully clockwise.
4. Twist the System Power switch to turn the DSR system ON.
5. Turn your external signal source ON and enable your desired signal. Consult the manual of your external signal source, if needed, for instructions on operating the unit.

### 4.3 Using an External Amplifier

This application uses an external amplifier and the DSR system's internal waveform generator.

**NOTE: Consult your amplifier specifications to determine the system gain.**

#### 4.3.1 Setup Procedure

Complete the following steps to connect the DSR 100-25 system and other required equipment.

1. **Connect 3110A Accessories:** If not already connected, follow the instructions in the **System Setup** section of this manual to connect the 3110A accessories.
2. **Connect External Amplifier:** Use a BNC cable to connect from the BNC connector labeled Signal Out located on the DSR 100-25 3110A waveform generator's front panel to the signal input connector on the external amplifier. See **Figure 4.6**.

3. **Connect the Outputs:** Using the supplied mating output connectors and wiring appropriate for your application, connect from the external amplifier's positive and negative output connectors to the device under test. See **Figure 4.6**.

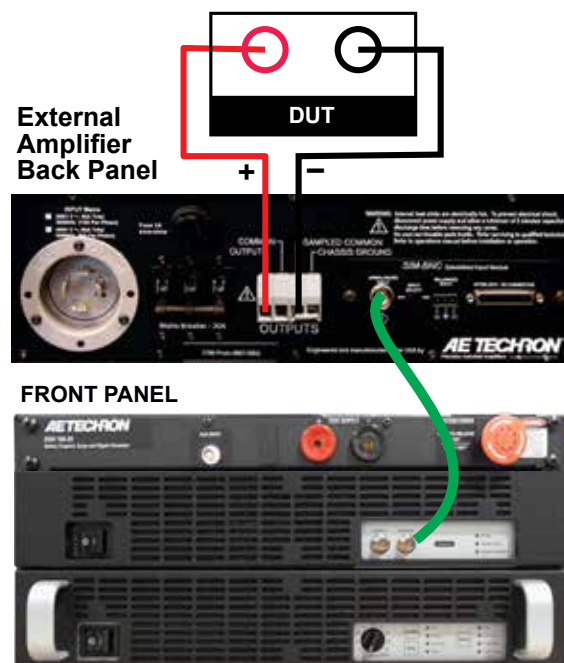

Figure 4.6 – Connecting an External Amplifier

#### 4.3.2 Startup Procedure:

Complete the following to enable the DSR 100-25 system: Refer to **Figure 4.7** for control locations.

1. Use the monitor's power switch (last button on the right) to turn on the monitor.
2. Make sure the breaker/power switch on the amplifier module is in the OFF position.



Figure 4.7 – Locations of Controls for Operation with an External Amplifier

3. Make sure the power switch on the 3110A controller is in the ON position.
4. Make sure the Gain control on the amplifier module is fully counter-clockwise.
5. Turn the System Power switch to turn the DSR system ON.
6. Turn your external amplifier ON. Consult the manual of your external amplifier, if needed, for instructions on operating the unit.
7. Wait for the 3110A software to load (loading will take up to 30 seconds). Then open the on-screen Help system for help with System Calibration and Operation.

## 5 Maintenance

Simple maintenance can be performed by the user to help keep the equipment operational. The following routine maintenance is designed to prevent problems before they occur. See the “Troubleshooting” section for recommendations for restoring the equipment to operation after an error condition has occurred.

Preventative maintenance is recommended after the first 250 hours of operation, and every three months or 250 hours thereafter. If the equipment environment is dirty or dusty, preventative maintenance should be performed more frequently.

The procedures outlined in this section are directed towards an experienced electronics technician; it assumes that the technician has knowledge of typical electronics safety and maintenance procedures.

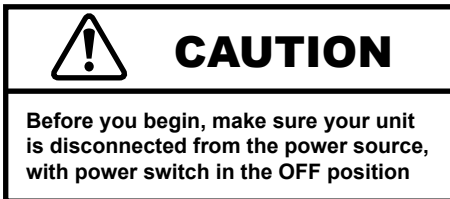

### 5.1 Clean Filter and Grill on Amplifier Module

#### Tools Required

The recommended equipment and supplies needed to perform the functions required for this task are described below.

- Vacuum cleaner
- Damp cloth (use water only or a mild soap diluted in water)

To ensure adequate cooling and maximum efficiency of the internal cooling fans, the amplifier's front grill should be cleaned periodically. To clean the amplifier grill and filter, complete the following steps:

1. Turn completely down (counter-clockwise) all level controls and turn the amplifier OFF. Disconnect the amplifier from its power source.
2. Using a vacuum cleaner, vacuum the front ventilation grill.
3. Remove the front grill by pulling the grill firmly away from the amplifier.
4. Remove the filter and vacuum. You can also clean the filter using mild soap and water.  
**IMPORTANT:** Make sure the filter is completely dry before reinstalling in the amplifier.
5. Using a damp cloth, clean the front ventilation grill. Dry with a clean cloth or allow to air dry.  
**IMPORTANT:** Grill should be completely dry before plugging in or restarting amplifier.
6. Reinstall the filter and replace the amplifier front grill.

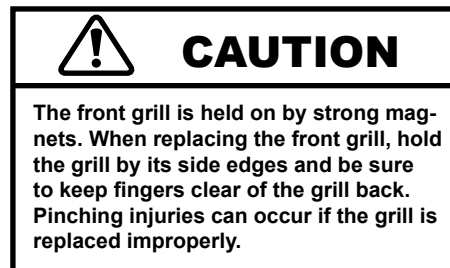

## 6 Troubleshooting

If the DSR 100-25 system is not operating correctly, review the topics below for help with troubleshooting the problem. If the condition or error you are experiencing is not listed below, please contact **AE Techron Technical Support** at 574-295-9495 for additional help.

**PROBLEM:** The system has no signal output.

**A:** Check to make sure signal input is being generated using the 3110A Standards Waveform Generator or a stand-alone signal generator.

To see if signal is being generated by the 3110A, access the 3110A SWG software, and check to make sure that output is enabled for the test sequence and that the “Segment Enabled” option is selected for all wave segments.

If using a stand-alone signal generator, check the BNC cable connecting from the signal generator to the AMPLIFIER INPUT DIRECT connector on the front panel of the DSR system. Make sure the connections at both ends are secure.

**PROBLEM:** System does not power on; no LEDs are lit on the 3110A or the amplifier module.

**A:** Check that the power cord is completely inserted into the DSR 100-25’s back panel power inlet. Check that the power cord is connected to a power outlet and the AC mains is switched on.

**PROBLEM:** 3110A unit does not power on.

**A:** Check the front-panel power switch on the 3110A to make sure the unit is in the ON position.

**PROBLEM:** The SWG Windows Remote software will not load or will not connect remotely to the 3110A; instead, an error message indicates a “version mismatch.”

**A:** The 3110A software and the Windows Remote software versions must match for successful interaction between the two modules. See the topic “Updating the 3110A” in the **3110A Help** files for

### Amplifier Module



Figure 5.1 – Amplifier Module’s Breaker/Power Switch Location

information about how to install new versions of these modules.

**PROBLEM:** No LEDs are lit and/or fans are inoperative on the amplifier module.

**A:** Check the breaker/power switch on the amplifier module to make sure it is in the ON position. See **Figure 6.1**.

**PROBLEM:** The amplifier module is displaying the Overvoltage Warning message/LED.

**A:** The amplifier module will protect itself from AC mains voltage that is 10% above the 120V rated operating voltage. If this condition occurs, reduce the AC mains voltage to the proper level. When the line voltage condition is corrected, the amplifier module will automatically reset, and the system will return to Run mode.

If the amplifier module does not automatically reset, the amplifier’s internal transformers may need to be rewired. See the Factory Service information at the end of this section.

**PROBLEM:** The amplifier module is displaying the Overtemp Warning message/LED.

**A:** The amplifier module may overheat due to one or both of the following conditions: Excessive power requirements and/or inadequate air flow.

An amplifier module will overheat if the required power exceeds the system’s capabilities. High duty cycles and low-impedance loads are especially prone to cause overheating. To see if excess power requirements are causing overheating, check the following:

1. Check the “Specifications” section in this manual to verify that your application’s requirements fall within the capabilities of this system.
2. Check for faulty output connectors and/or load.
3. Check for undesired DC offset at the output and on the input signal.

If the amplifier module chronically overheats with suitable power and load conditions, then the system or amplifier module may not be receiving adequate airflow. Check the following to determine the cause of inadequate airflow:

1. Check the amplifier module’s air filter for excess dirt and dust. Perform the steps outlined in the “Maintenance” section to clean the amplifier filter.
2. Visually inspect fans to assure correct operation while the system is on. Any inoperative, visibly slow, or reverse-spinning fans should be replaced. Please see the Factory Service information at the end of this section.

An Overtemp condition places the unit in Standby mode. If the Overtemp pulse is extremely short, as in the case of defective wiring or switches, the Overtemp pulse may be too brief to observe.

**Resetting After Overtemp:** To reset the system after an Overtemp has occurred, make sure fans are running in the amplifier module, then remove the input signal from the system input. Allow the fans to run for five minutes, and then push the Reset button on the amplifier module to reset the system.

**PROBLEM:** The amplifier module is displaying the Output Device Fault Warning message/LED.

**A:** The amplifier module contains protection circuitry that disables the module if an output stage is behaving abnormally. This usually indicates an output transistor has shorted.

To clear the Fault condition, follow these steps:

1. Turn off the signal source.
2. Turn off the system
3. Turn the system back on. If the Fault LED

doesn’t illuminate again, turn the signal source on.

4. If the Fault LED is still illuminated and the Fault condition doesn’t clear, return the system for Factory Service. Please see the Factory Service information at the end of this section.

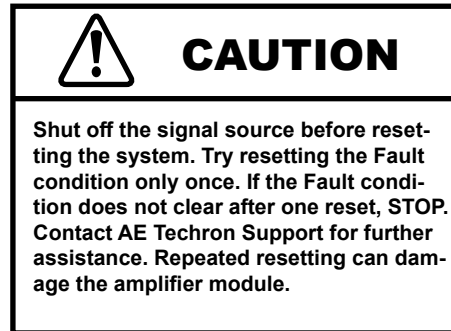

## 6.1 Factory Service:

If the troubleshooting procedures are unsuccessful, the DSR system may need to be returned for Factory Service. All units under warranty will be serviced free of charge (customer is responsible for one-way shipping charges as well as any custom fees, duties, and/or taxes). Please review the “Warranty” for more information.

All service units must be given Return Authorization Tickets by AE Techron, Inc. before being returned. Return Authorization Tickets can be requested on our website or by contacting our Customer Service Department.

Please take extra care when packaging your unit for repair. It should be returned in its original packaging or a suitable alternative. Replacement packaging materials can be purchased for a nominal fee.

Please send all service units to the following address and be sure to include your Return Authorization Ticket Number on the box.

AE Techron, Inc.

Attn: Service Department / RMA#

2507 Warren Street

Elkhart, IN 46516