

AETECHRON



DSR 100 Series

**Dropout, Surge, Ripple Simulator
and AC/DC Voltage Source**

Operation Manual for DSR 100-75 and DSR 100-155 Models

Three-Year, No-Fault Warranty

SUMMARY OF WARRANTY

AE TECHRON INC., of Elkhart, Indiana (Warrantor) warrants to you, the ORIGINAL COMMERCIAL PURCHASER and ANY SUBSEQUENT OWNER of each NEW **AE TECHRON INC. product, for a period of three (3) years from the date of purchase, by the original purchaser (warranty period) that the product is free of defects in materials and workmanship and will meet or exceed all advertised specifications for such a product. We further warrant the new AE Techron product regardless of the reason for failure, except as excluded in the Warranty.**

ITEMS EXCLUDED FROM WARRANTY

This AE Techron Warranty is in effect only for failure of a new AE Techron product which occurred within the Warranty Period. It does not cover any product which has been damaged because of any intentional misuse, or loss which is covered under any of your insurance contracts. This warranty does not extend to any product on which the serial number has been defaced, altered, or removed. It does not cover damage to loads or any other products or accessories resulting from **AE TECHRON INC.** product failure. It does not cover defects or damage caused by the use of unauthorized modifications, accessories, parts, or service.

WHAT WE WILL DO

We will remedy any defect, regardless of the reason for failure (except as excluded), by repair or replacement, at our sole discretion. Warranty work can only be performed at our authorized service centers or at our factory.

Expenses in remedying the defect will be borne by **AE TECHRON INC.**, including one-way surface freight shipping costs within the United States. (Purchaser must bear the expense of shipping the product between any foreign country and the port of entry in the United States and all taxes, duties, and other customs fees for such foreign shipments.)

HOW TO OBTAIN WARRANTY SERVICE

When you notify us or one of our authorized service centers of your need for warranty service, you will receive an authorization to return the product for service. All components must be shipped in a factory pack or equivalent which, if needed, may be obtained

from us for a nominal charge. We will take corrective actions and return the product to you within three weeks of the date of receipt of the defective product, or will make available to you a product of equal or better performance on temporary loan until your product can be repaired or replaced and returned to you. If the repairs made by us are not satisfactory, notify us immediately.

DISCLAIMER OF CONSEQUENTIAL AND INCIDENTAL DAMAGES

You are not entitled to recover from us any consequential or incidental damages resulting from any defect in our product. This includes any damage to another product or products resulting from such a defect.

WARRANTY ALTERATIONS

No person has the authority to enlarge, amend, or modify this warranty. The warranty is not extended by the length of time for which you are deprived of the use of this product. Repairs and replacement parts provided under the terms of this warranty shall carry only the unexpired portion of this warranty.

DESIGN CHANGES

We reserve the right to change the design of any product from time to time without notice and with no obligation to make corresponding changes in products previously manufactured.

LEGAL REMEDIES OF PURCHASER

There is no warranty that extends beyond the terms hereof. This written warranty is given in lieu of any oral or implied warranties not contained herein. We disclaim all implied warranties, including, without limitation, any warranties of merchantability or fitness for a particular purpose. No action to enforce this Warranty shall be commenced later than ninety (90) days after expiration of the warranty period. This statement of warranty supersedes any others contained in this manual for AE Techron products.

AE TECHRON INC. Customer Service Department

2507 Warren St. Elkhart, IN, 46516, U.S.A.
(574) 295-9495
www.aetechron.com

Contents

1	About the DSR Series Test Systems.....	5
1.1	Features	5
1.2	Disclaimer.....	5
2	System Setup.....	6
2.1	Safety First.....	6
2.2	Unpacking and Installing	6
2.3	Check Contents.....	6
2.4	DSR 100 Series System Location.....	7
2.5	Connect the Signal Source.....	7
2.6	Connect the Test Supply	9
2.7	Connect the Power Source	9
2.8	Startup Procedure	10
2.9	Shutdown Procedure.....	11
3	Operation	12
3.1	System Controls and Connectors.....	12
3.2	3110A Operation.....	13
3.3	Amplifier Module Operation	14
3.4	ELP Optional Feature Accessory.....	17
4	Applications.....	18
4.1	ISO 16750-2 – Section 4.8 Testing.....	18
4.2	Configure for Low-Voltage Testing	20
4.3	Using an External Signal Source.....	21
4.4	Using an External Amplifier	23
5	Maintenance	25
5.1	Clean Filters and Grills on Amplifier Modules.....	25
5.2	Clean Cabinet Interior	25
6	Troubleshooting	26
6.1	Factory Service:	27



Figure 1.1 – DSR 100-75 and DSR 100-155 Test Systems

1 About the DSR Series Test Systems

Congratulations on your purchase of an AE Techron DSR Series test system, designed for use in EMC testing as a dropout, surge, ripple simulator and AC/DC voltage source. A DSR test system provides a complete, single-box solution for immunity testing. It includes a simple-to-use yet powerful 3110A Standards Waveform Generator matched with an industry leading power supply technology and comes with an extensive library of tests for many automotive and aviation standards.

The DSR system is 4-quadrant, allowing it to source and sink current. The DSR system has power in reserve; each model provides continuous DC power as rated, and is able to provide 4X rated power for in-rush testing up to 200 ms, as is required in DO 160 Section 16.

The AE Techron brand is known throughout the world for its robust precision amplifiers and test systems as well as its product service and support.

***Some Standards' tests included in the 3110A Library may require voltages above the maximum voltage available in your DSR 100-25 system. To run those tests, connect the 3110A to a different amplifier or amplifier system that can generate the required voltage.**

1.1 Features

- Includes a library of 3000+ pre-entered Automotive and Aviation Standards' test routines
- Operate as a free-standing system using the included monitor, keyboard and mouse, or control via LAN
- Very easy to modify existing tests or build new test sequences
- Can function as a controller or node in a larger test system via built-in LAN and GPIO controls

1.2 Disclaimer

Although AE Techron has made substantial effort to ensure the accuracy of the Standards' test files (SWG files), which are included with the DSR 100-series cabinet, no warranty, expressed or implied, is made regarding accuracy, adequacy, completeness, legality, reliability or usefulness of the information provided. It is the responsibility of the user to ensure the accuracy and applicability of these test files for their intended purposes.

2 System Setup

2.1 Safety First

Throughout these instructions, special emphasis is placed on good safety practices. The following graphics are used to highlight certain topics that require extra precaution.

DANGER

DANGER represents the most severe hazard alert. Extreme bodily harm or death will occur if these guidelines are not followed. Note the explanation of the hazard and instruction for avoiding it.

WARNING

WARNING alerts you to hazards that could result in severe injury or death. Note the explanation of the hazard and the instructions for avoiding it.

CAUTION

CAUTION indicates hazards that could result in potential injury or equipment or property damage. Once again, note the explanation of the hazard and the instructions for avoiding it.

2.2 Unpacking and Installing

Your system will be delivered to the ship-to address enclosed in a wooden crate with special, shock-absorbing pads. With the addition of packaging, the unit can weigh several hundred pounds (kilograms).

To uncrate the product, follow the **Unpacking Your Product** instructions included with your shipment. The cabinet can be removed from the crate using

WARNING

Use caution when using a forklift to move this system. Crushing bodily injury can result if care is not taken during uncrating and installation.

the built-in hinged ramp or by using a forklift or other suitable equipment to glide the amplifier from the crate.

Forklift provisions are provided in the base of the cabinet to facilitate this removal procedure (see **Figure 2.1**).



Figure 2.1 – Provisions in Unit’s Base for Forklifts

CAUTION

Use caution when inserting the forklift tynes into the unit’s lifting base. Do not drag the tynes heavily against the bottom of the unit when entering or exiting the base. Keep the tynes level at all times while handling the unit.

The amplifier has been tested and inspected for damage before leaving the factory. Carefully unpack and inspect the product for damage. **Please note any damage for future reference and notify the shipping company immediately if damage is found.** Also, please save the shipping crate and pallet as evidence of damage and/or for returning the amplifier for repair.

2.3 Check Contents

In addition to the DSR system, your shipment should include the following:

1. LCD monitor
2. Monitor power cord
3. HDMI-to-DVI monitor cable
4. USB mouse
5. USB keyboard
6. Male pin-plug connectors (2)

7. Ethernet cable
8. Mouse pad
9. Quick Start Guide
10. DSR Series Operation Manual on USB drive



2.4 DSR 100 Series System Location

DSR 100 Series test systems are mounted on wheels to allow rolling on a flat, smooth surface. The system's wheels should be used only for moving the system over a short distance to position the unit in its permanent location. DO NOT use the system's wheels to move the system over long distances. To avoid possible tipping, always push the system from the front and avoid rough or pitted surfaces.

Locate your system near a three-phase power source. Allow enough clearance at the front and back to allow adequate airflow and hot air discharge through the system's rear. See **Figure 2.2** for clearance recommendations.

All of the wheels on the system are equipped with a leveling pad that can be used to adjust the height of each wheel (see **Figure 2.3**). This leveling mechanism will also act to lock each wheel in place and prevent unintentional movement of the unit.

Two covers have been provided to insert into fork lifting openings at the front of the system once it has been set in its final location.

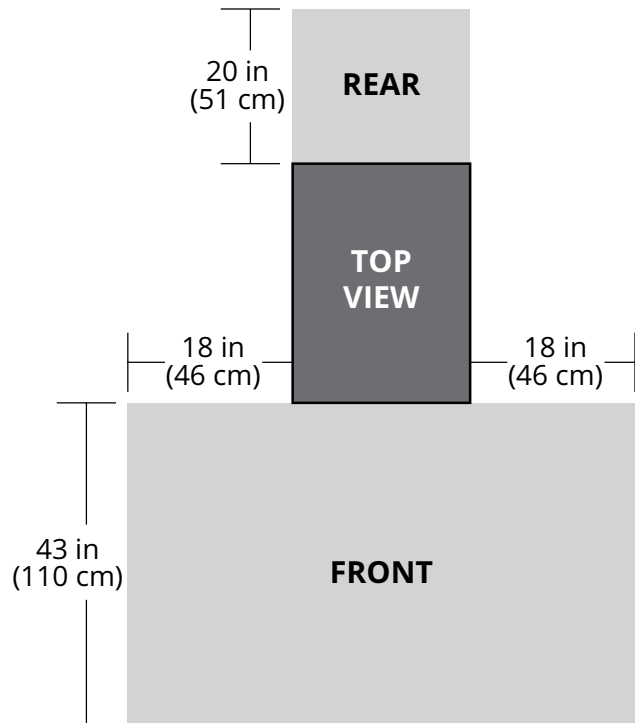

Figure 2.2 – Clearance Recommendations for System Placement



Figure 2.3 – Leveling pads on Wheels

2.5 Connect the Signal Source

Your DSR 100 system comes with a 3110A Standards Waveform Generator that includes an extensive library of tests for many automotive, aviation, and industry standards. The 3110A provides a powerful yet simple-to-use interface to help streamline the testing process. 3110A test files (.swg) are easy to link, build from scratch, or customize using time-saving controls like triggers and loops with changing variables. Plus, the 3110A's intuitive, drag-and-drop interface makes it easy to modify existing tests or build new tests.

The 3110A can produce standard signals and waveforms with or without a DC offset. Frequency, amplitude and DC offset can be fixed or swept, and sinewave sweeps can be linear, logarithmic or exponential. It can create dropouts and surges and can also produce ripple waveforms of up to 1 MHz.

As it ships from the factory, the DSR 100 series test systems are capable of performing thousands of different EMC immunity tests. However, in order to meet some test requirements, changes to the DSR system’s configuration may be needed.

These alternative configurations include:

ISO 16750-2 – Section 4.8 Testing: The DSR 100 series system can be used to perform ground reference and supply offset testing as required by ISO 16750-2 – Section 4.8 and similar standards.

Low-Voltage Testing: Standards Tests having a maximum voltage of less than 30V may require an increase in the signal-to-noise performance of the DSR 100 system in order to achieve accurate results.

Use External Signal Source: The DSR 100 series system can be configured to use an external signal source in place of the internal 3110A signal generator,

Use External AE Techron Amplifier: The DSR 100 series system can be configured to use an external AE Techron amplifier in place of the internal amplifier module.

The settings and connections required for these special uses are detailed in the **Applications** section of this manual.

2.5.1 Use the 3110A for Signal Generation

Connect the Signal Input

The 3110A is connected internally to the DSR 100 system’s integrated amplifier modules, so you only need to connect the 3110A cables and accessories in order to use the 3110A for signal generation.

Connect Peripheral Equipment

Complete the following steps to connect the 3110A cables and accessories provided to the DSR 100 Series’ SWG Peripheral Connections panel located on the back of the system. Refer to **Figure 2.4** for component locations.

1. Plug the USB keyboard into the USB port labeled KEYBOARD.
2. Plug the USB mouse into the port labeled MOUSE.
3. Plug the HDMI to DVI cable into the HDMI port labeled MONITOR and then connect the cable to the DVI port on the monitor.
4. Plug the monitor power cord into the auxiliary 120V power outlet.
5. **OPTIONAL:**
 - A. To connect the DSR system to be accessed and controlled through a network: Plug the Ethernet cable to the Ethernet port labeled NETWORK, and then plug the Ethernet cable into a router, switch or hub on the network.
 - B. Use the USB port labeled FLASH DRIVE for software updates or to move test files to and from the 3110A system.

Note on Network Control of the 3110A

After network control of the 3110A has been implemented, the monitor, keyboard and mouse can be disconnected from the 3110A and the system

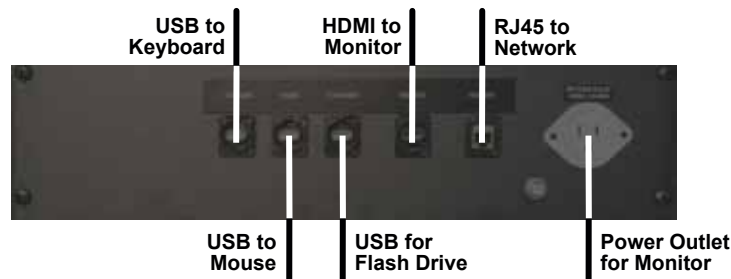

Figure 2.4 – Connecting the 3110A Cables and Accessories on a DSR Series System

can be operated remotely. See the topic “Remote Operation” in the **3110A Help** files for more information

2.6 Connect the Test Supply

! WARNING

ELECTRIC SHOCK HAZARD.
Output potentials can be lethal. Make connections only with AC Power unplugged or switched off at the source and the system's AC power switch in the OFF position.

Make sure the DSR system is turned off and AC power is disconnected. Using the supplied pin-plug connectors and wiring appropriate for your application, connect from the DSR system's positive and negative test supply connectors to the device under test. See **Figure 2.5**.



Figure 2.5 – Test Supply Connections (DSR 100 System Output)

! WARNING

ELECTRIC SHOCK HAZARD. Power supply wiring should only be performed by a qualified, licensed electrician.

2.7 Connect the Power Source

Complete the following steps to connect the cabinet to a 208V (or optional 400V) three-phase power source:

1. Wear safety goggles.
2. Disconnect your AC power source.
3. Open the access door on the back of the cabinet and locate the power block, which can be found at the bottom of the cabinet, behind the fuse and AC inlet panel.
4. Route the AC power input cable into the cabinet through the cable strain relief (located on the fuse and AC inlet panel). See **Figure 2.6**.



Figure 2.6 – Routing the AC power input cable



Figure 2.7 – Wiring the AC distribution block

5. Locate the power distribution block at the bottom of the cabinet. Open the distribution block cover and connect the AC power line to the AC input terminals as shown (see **Figure 2.7**)
6. If connecting to an AC power cord, verify connector wiring for phases, neutral and safety ground. Verify that proper phase, neutral and safety ground connections have been made at the AC mains breaker.

2.8 Startup Procedure

Refer to **Figure 2.8** and complete the following steps to power up the DSR system.

1. Use the monitor's power switch (last button on the right) to turn on the monitor.

2. Check the power/breaker switch on the 3110A and all amplifier modules. Make sure all units are switched ON.
3. Twist the SYSTEM POWER switch to turn the DSR system ON.
4. Wait for the 3110A interface to load (loading will take up to 30 seconds). Press the Help button to access this manual from within the program.
5. Run the System Calibration test to determine the proper settings for your system. See the **“Calibration”** section in the **3110A Help** files for more information.

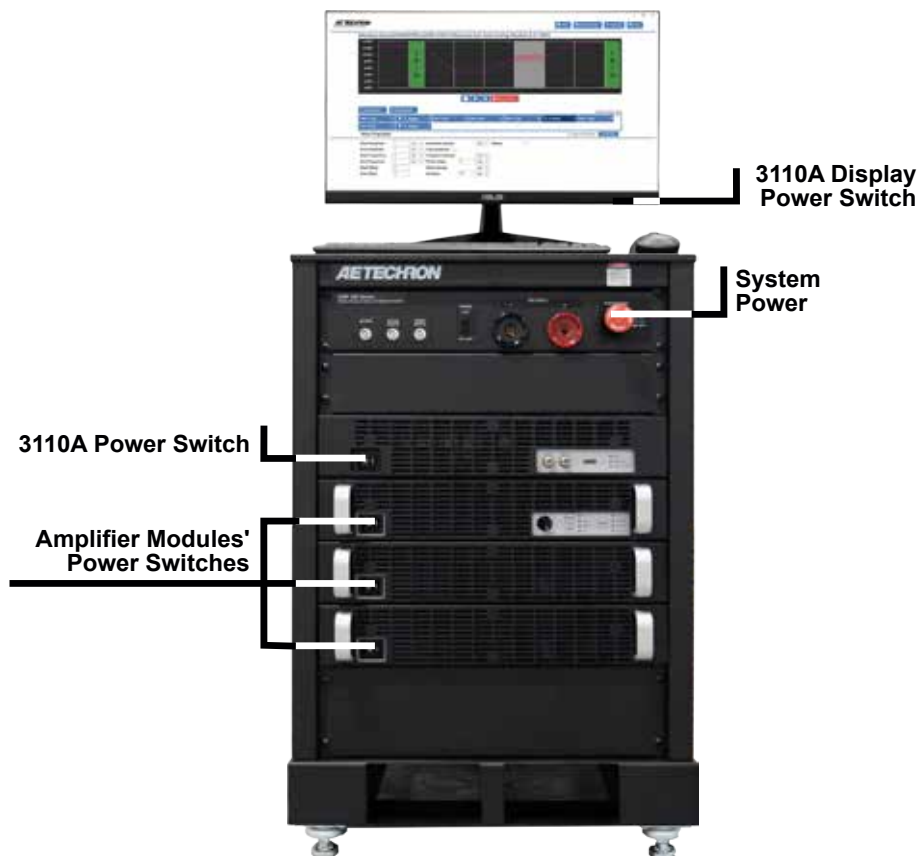

Figure 2.8 – DSR System Power Switch Locations for Startup Procedure

2.9 Shutdown Procedure

IMPORTANT: Any powered amplifiers that are connected to the 3110A must first be disabled before shutting down the 3110A or DSR System. Failure to follow the proper shutdown procedure can result in damage to the amplifiers or any connected load/DUT.

Complete the following to safely shut down a 3110/ amplifier combination or DSR System: See **Figure 2.9**.

1. Make sure all amplifiers connected to the system are disabled. To quickly disable AE Techron amplifiers, press the Stop button on

the front panel of any amplifier to place all connected units in Standby mode. Or you can turn the amplifier(s) OFF using the amplifier's power switch or breaker. See the "Operation" section in this manual for power switch location. For non-AE Techron amplifiers, consult the product instructions to determine the best method for disabling those units.

2. After all amplifiers have been disabled, turn the system OFF by pressing the System Power button.

NOTE: If the 3110A is not connected to any amplifiers, it can be safely shut down by simply pressing the 3110A front-panel power switch.

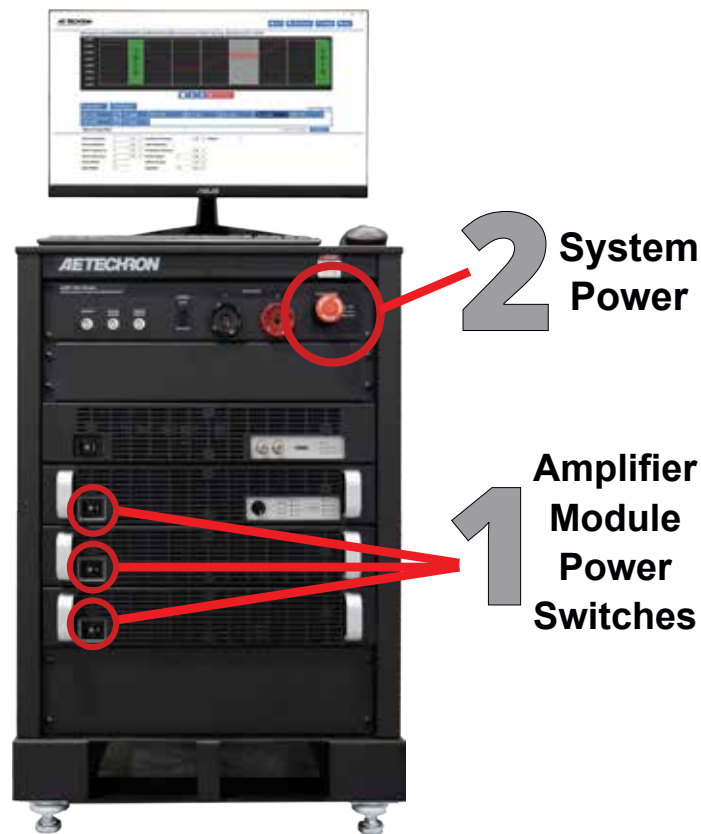

Figure 2.9 – DSR System Power Switch Locations for Shutdown Procedure

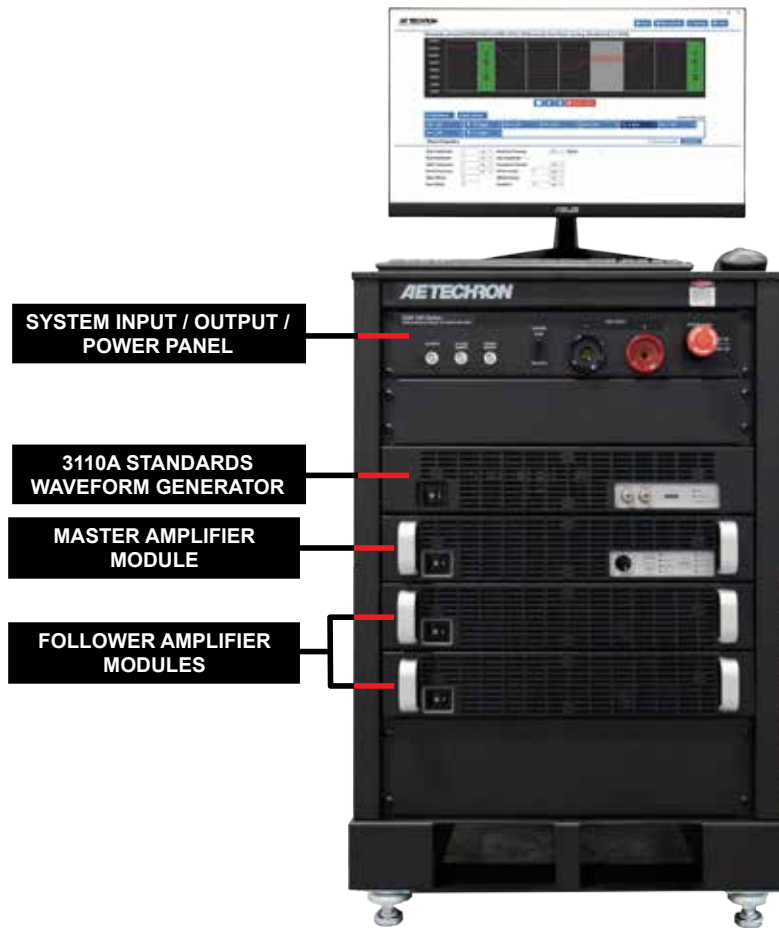

Figure 3.1 – DSR 100 Series Module Locations

3 Operation

IMPORTANT: Before operating the DSR system, the **3110A System Calibration Procedures** should be performed to verify the correct System Gain and DC Offset settings for your system. See the topic “System Calibration” in the **3110A Help** files for more information.

System Overview

Your DSR 100 system provides one integrated signal generation device to produce the test sequences, and three or six amplifier module to reproduce and amplify the output signal. The location of these modules is specified in **Figure 3.1**.

3.1 System Controls and Connectors

System level controls and connectors are located on the Input/Output/Power panel installed at the top front of the unit. Refer to **Figure 3.2** for component locations.

Direct Signal Input: An unbalanced BNC connector is used to provide the input signal from an external signal generator to the DSR 100 system.

Voltage Monitor: An unbalanced BNC connector is provided for voltage monitoring. 1V = 10V.

Current Monitor: An unbalanced BNC connector is provided for current monitoring. 1V = 15A (DSR 100-75) or 1V = 30A (DSR 100-155).

Chassis Float/Grounded Switch: This toggle switch enables the DSR 100 system to be configured for ground reference and supply offset testing as required by ISO 16750-2 – Section 4.8 and similar standards.

When in the **Float** position, the reference of the system chassis will be changed from ground to float. **This will also reduce the stability margin of the system. Use caution when operating**

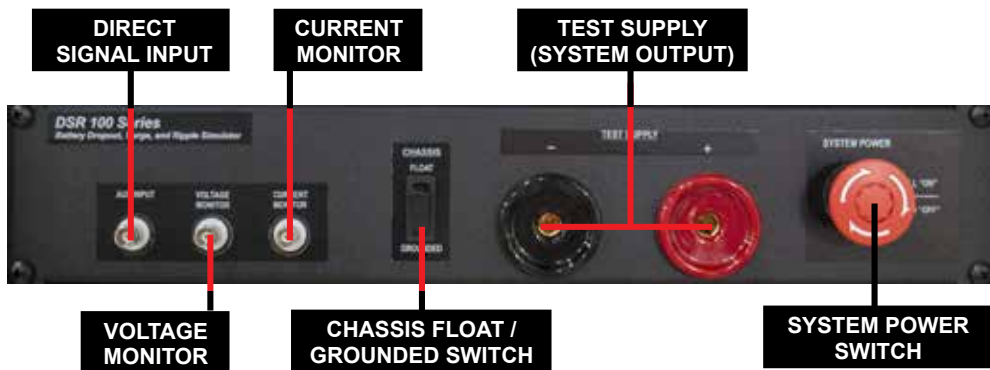

Figure 3.2 – DSR 100 Series System Controls and Connectors

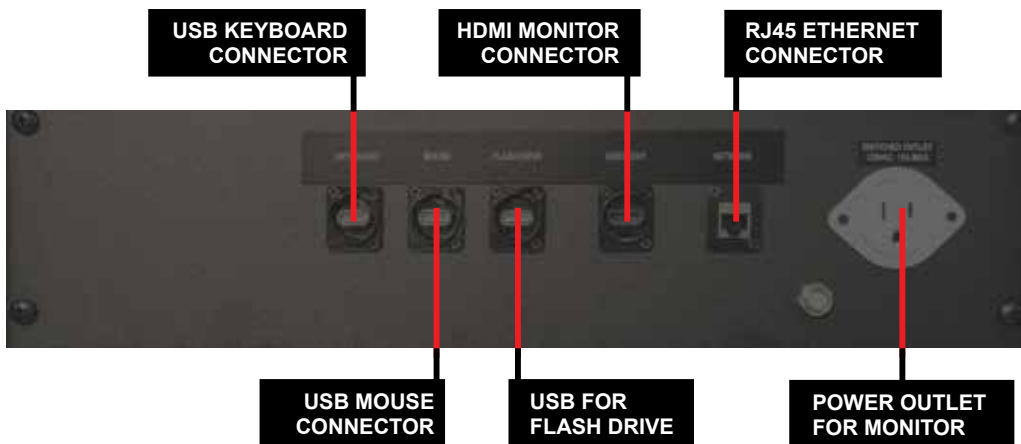

Figure 3.3 – Back-Panel Connectors for 3110A Accessories

with a floating ground. Follow the directions for output connections as required by the Standard.

Test Supply (System Output): A pair of high-current pin-plug connectors are provided to supply the test signal to the DUT. Mating connectors are provided.

System Power: A power/emergency stop switch is provided which controls the power supply to the system and all system components. Turn clockwise to power the system on. Press in to power off the system.

3.2 3110A Operation

The AE Techron 3110A Standards Waveform Generator provides an intuitive interface for waveform sequence creation and generation. The following sections describe the 3110A connection and operation.

3.2.1 3110A Accessories

The accessories required for operation of the 3110A are connected using the Accessories panel located on the cabinet rear. Refer to **Figure 3.3** for connector locations.

3.2.2 3110A Front-Panel Controls, Connectors, and Indicators

See **Figure 3.4** for item locations.

Power Switch: The Power switch controls the AC mains power to the 3110A. Switch to the ON

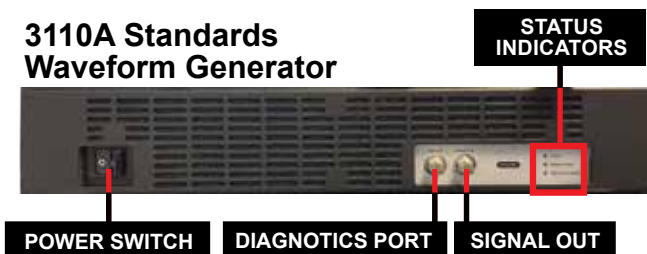

Figure 3.4 – 3110A Front-Panel Controls, Connectors, and Indicators

position (I) to turn the 3110A on. Switch to the OFF position (O) to turn the 3110A off.

Signal In (Diagnostics Port): An unbalanced BNC connector is available for diagnostic use by Factory Service..

Signal Out: An unbalanced BNC connector is used to provide the signal from the 3110A to an external amplifier.

Power Indicator: The LED will light when the 3110A has AC power and is ready for operation.

System Fault Indicator: The LED will light if a fault condition occurs in the 3110A system.

Signal In Enabled: The LED will light when diagnostic equipment connected to the 3110A's Signal In Port and enabled.

3.2.3 3110A Software Basic Operation

To select a pre-programmed test from the Standard's Library, simply use the Files button to open the files window and select the test file. Refer to **Figure 3.5** for on-screen controls' locations.

Custom test files can be created by adding waveforms and controls to the test sequence display. For help in getting up and running quickly on the 3110A, please see the "3110A Tutorials" section in the **3110A Help** files.

Please also refer to the **3110A Help** files for general operation and troubleshooting information,

The **Help** files are available by selecting the Help button from the 3110A main window. They are also provided in pdf format on the USB drive shipped with your DSR 400 system, or on the AE Techron website at aetechron.com.

3.3 Amplifier Module Operation

Your DSR system contains three or six amplifier modules to provide the high-current output required for many Standards' tests. These modules have been configured as a parallel multi-amp system, increasing the system's output current capabilities.

In multi-amp configurations, the individual amplifier modules are interlocked together, with one Master amplifier controlling the operation of all of the amplifier modules in the system. With the exception of the breaker/power switches, a control operated on the Master amplifier will perform that action on all of the amplifier modules in the system.

The following sections describe the controls and indicators found on the DSR Series amplifier modules.

3.3.1 Breaker/Power Switches

The Breaker/Power switch on each amplifier module controls the AC mains power to that module. Switch to the ON position (I) to turn the module on. Switch to the OFF position (O) to turn the module off. See **Figure 3.6**.

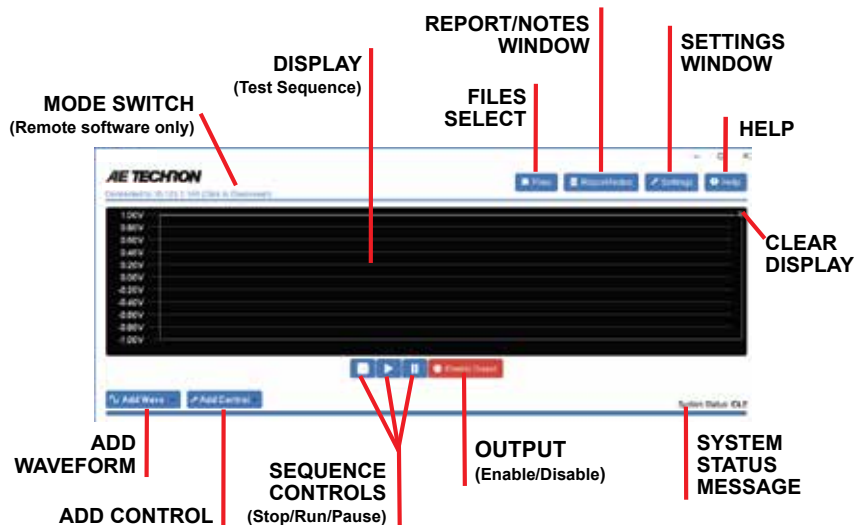

Figure 3.5 – 3110A On-screen Controls

The Breaker/Power switch also serves as a breaker. When the breaker is tripped, the Breaker/Power switch moves to a neutral position between ON and OFF. To reset the breaker, turn the module OFF (O) and then turn it back ON (I).

3.3.2 Master Amplifier Module Front-Panel Controls

This section provides an overview of front-panel controls found on the DSR Master amplifier module. See **Figure 3.7** for item locations.

Level Control

The Level Control increases/decreases the gain from 0 - 100% of the overall gain. Turn the Level Control fully clockwise for maximum amplifier system output..

Input Buttons

Three push buttons on the module’s front panel control basic operation of the amplifier modules.

Enable – Enable will release all of the amplifier modules from Stop mode and place the amplifier system in Run mode (both Ready and Run LEDs on the Master amplifier module will be lit). When the amplifier system is placed in Run mode, the high-voltage transformers will be energized and the system will amplify the input signal.

Stop – Stop will place all of the amplifier modules in Stop mode (both Standby and Stop LEDs on the Master amplifier module will be lit). When the amplifier system is in Stop mode, the low-voltage transformers are energized but the high-voltage transformers are not.

Reset – When some fault conditions occur in one or more amplifier modules, the amplifier system will be placed in Standby mode. To release the system from Standby mode, clear the fault condition and then press the Reset button on the Master amplifier module. If the system is in Run mode when the fault condition occurs, pressing the Reset button will return the system to Run mode. If the system is in Stop mode when the fault condition occurs, pressing the Reset button will return the system to Stop mode.

Master Amplifier Module



BREAKER/POWER SWITCH

Follower Amplifier Module



BREAKER/POWER SWITCH

Figure 3.6 – Amplifier Module Breaker/Power Switches

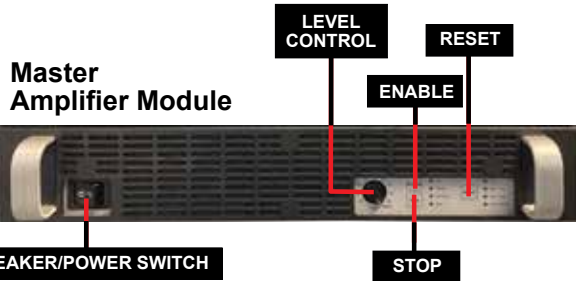

Figure 3.7 – Master Amplifier Module Controls



Figure 3.8 – Master Amplifier Module Status Indicators

3.3.3 Front-Panel Status Indicators

This section provides an overview of Front-Panel status indicators found on the DSR Master amplifier module. Please refer to **Figure 3.8** for item locations.

Main Status Indicators

Four Main Status indicators are located on the Master amplifier module’s front-panel. These LEDs monitor the internal conditions of the amplifier system and indicate the current state of operation. The chart in **Figure 3.9** details the operational modes indicated by these Main Status indicators.

Figure 3.9 – Main Status Indicators

● ● ● Indicator is lit ● Indicator is not lit ○ Indicator may be lit

Main Status Indicators	State of Operation	Action Needed to Return to Run Mode
● Run ● Ready ● Standby ● Stop	Run mode: The amplifier system’s high-voltage transformers are energized and the system will amplify the input signal. Run mode is initiated by: (1) the Enable push button when the system is in Standby mode, or (2) when the system powers up..	N/A
● Run ○ Ready ● Standby ● Stop	Standby mode: Standby mode indicates that the amplifier system is functioning properly and all Fault Status modes are clear, but it is being held in Standby by an external condition. The amplifier system will enter Standby mode briefly after powering up, and then will move automatically into Run mode. In Standby mode, the amplifier system’s low-voltage transformers are energized but the high-voltage transformers are not.	If the system remains in Standby mode, the DSR 100 system may require servicing. Please contact AE Techron Technical Support.
● Run ● Ready ● Standby ● Stop	Stop mode: When the Stop button on the Master amplifier module’s front panel is pressed, the amplifier system will enter Stop mode. In Stop mode, the amplifier system’s low-voltage transformers are energized but the high-voltage transformers are not.	To release the amplifier system from Stop mode, press the Enable button on the Master amplifier module.

Fault Status Indicator

Four Fault Status indicators are located on the Master amplifier module’s front-panel. These LEDs monitor the internal conditions of the amplifier system and will illuminate when a fault condition occurs. Depending on the fault condition, the amplifier system may be placed in Standby/Fault mode

when a fault condition occurs. Refer to the chart in **Figure 3.10** to determine the fault condition being indicated and the action required to clear the fault condition. Typically, the system can be released from Standby mode by pressing the Reset button on the Master amplifier module.

Figure 3.10 – Fault Status Indicators

● ● ● Indicator is lit ● Indicator is not lit ○ Indicator may be lit

Main Status Indicators	Fault Status Indicators	State of Operation	Action Needed to Clear Fault Condition and Return to Run Mode
● Run ● Ready ● Standby ● Stop	● Fault ● Over Load ● Over Temp ● Over Voltage	Output Fault status: This indicates that an Output Fault condition has occurred and the amplifier system has been placed in Standby mode. The Fault indicator will light under two conditions: 1) High-frequency oscillation is causing high shoot-through current; or 2) An output transistor has shorted, causing the output fault condition.	This fault condition cannot be cleared using the Reset button on the Master amplifier module’s front panel. See the Troubleshooting section for more information on diagnosing and clearing this fault condition.
● Run ● Ready ○ Standby ● Stop	● Fault ● Over Load ● Over Temp ● Over Voltage	Over Load status: This indicates that the output of the amplifier system could not follow the input signal due to voltage or current limits. Under normal operation with the factory-default settings, an Over Load condition will not place the system in Standby mode.	To remedy the Over Load fault during operation, turn down the level of the input signal until the Over Load indicator turns off.

Main Status Indicators	Fault Status Indicators	State of Operation	Action Needed to Clear Fault Condition and Return to Run Mode
<ul style="list-style-type: none"> ● Run ● Ready ● Standby ● Stop 	<ul style="list-style-type: none"> ● Fault ● Over Load ○ Over Temp ● Over Voltage 	<p>Over Temp status: The Master amplifier module monitors the temperature inside the system’s high-voltage transformers, low-voltage transformers, and in the output-stage heat sinks. The Over Temp indicator will light and the system will be placed in Standby mode when the temperature sensors detect a condition that would damage the system. If the Over Temp pulse is extremely short, as in the case of defective wiring or switches, the Over Temp LED may be lit too briefly to observe.</p>	<p>To reset after an Over Temp fault has occurred, make sure the fans are running in all of the amplifier modules, and then remove the input signal from the system. Allow the fans to run for about 5 to 15 minutes, and then push and hold the Reset button on the Master amplifier module’s front panel until the Standby LED turns off. Release the Reset button to return the system to Run mode. See the Troubleshooting section for information on correcting the cause of an Over Temp fault condition.</p>
<ul style="list-style-type: none"> ● Run ● Ready ● Standby ● Stop 	<ul style="list-style-type: none"> ● Fault ● Over Load ● Over Temp ● Over Voltage 	<p>Over Voltage status: This indicates that the AC mains voltage is more than +10% of nominal. The system will be forced to Standby when an Over Voltage condition occurs. When the Over Voltage condition is cleared, the system will automatically return to Run mode.</p>	<p>To clear an Over Voltage fault condition, the AC mains must be brought down to the nominal value. Once the Over Voltage condition has been cleared, press the Reset button on the Master amplifier module’s front panel to return the system to Run mode. If the system does not return to Run mode, it may require servicing. Please see the Troubleshooting section for more information.</p>

3.4 ELP Optional Feature Accessory

Your DSR 100 Series test system may be equipped with the optional “Electronic Load Protection” (ELP) accessory. This feature is designed to provide selectable levels of protection for very sensitive devices that the user may be testing. When the selected peak current is reached the amplifier will be put into standby until the RESET button is pressed or the amplifier is powered down and restarted.

The two rotary switches allow the user to select the peak current thresholds as required to protect the device under test. The threshold values for each position can be customized at the factory if needed. The positive and negative limits are independently selected. Setting the knob to the fully clockwise (OFF) setting disables this feature and returns the system to the normal current limit designed into the amplifier (see **Fig. 3.11**).

If the selected current is exceeded the amplifier will be put into standby to remove the output voltage and avoid damage to the device under test. The red LED indicator will light to alert the user that this feature has been activated. To reset the amplifier, reduce or remove the input signal and then press the RESET button. This will bring the amplifier back to the run mode and allow the testing to continue.



Figure 3.11 – ELP Optional Feature Controls

4 Applications

The DSR 100 system has been configured at the factory for use as a general-purpose system capable of generating the test signal for a wide range of Standards' testing.

When the **default** configuration is used, the 3110A controller in the DSR system will produce the test waveform and the amplifier module in the DSR system will amplify the test signal.

Four additional configurations are detailed in this manual:

ISO 16750-2 – Section 4.8 Testing: The DSR 100 system can be used to perform ground reference and supply offset testing as required by ISO 16750-2 – Section 4.8 and similar standards.

Low-Voltage Testing: Standards Tests having a maximum voltage of less than 30V may require an increase in the signal-to-noise performance of the DSR 100 system in order to achieve accurate results.

External Signal Source: The DSR 100 system can be configured to use an external signal source in place of the internal 3110A signal generator,

External Amplifier: The DSR 100 system can be configured to use an external amplifier in place of the internal amplifier. Note that the amplifier should be an AE Techron 7000 Series or equivalent.

Each alternate use requires different setup and startup procedures. Please refer to the following instructions to setup and operate the DSR 100 system according to your requirements.

4.1 ISO 16750-2 – Section 4.8 Testing

This application uses the DSR system's internal waveform generator and internal amplifier system to perform ground reference and supply offset testing as required by ISO 16750-2 – Section 4.8 and similar standards.

NOTE: When using this configuration, the DSR 100's system gain will be 10. When using the 3110A as a signal source, always confirm the system gain setting in the 3110A software to ensure waveform accuracy.

4.1.1 Setup Procedure

Complete the following steps to connect the DSR 100 system and other required equipment.

1. **Connect 3110A Accessories:** If not already connected, follow the instructions in the System Setup section of this manual to connect the 3110A accessories.
2. **Connect the Outputs:** Using the supplied pin-plug mating output connectors and wiring appropriate for your application, connect from the DSR 100 system's front-panel positive and negative test supply connectors to the DC supply source and the device under test as shown in **Figure 4.1**.

4.1.2 Startup Procedure:

Complete the following to enable the DSR 100 system: Refer to **Figure 4.2** for control locations.

3. Use the monitor's power switch (last button on the right) to turn on the monitor.
4. **IMPORTANT:** Make sure the Chassis switch is in the Float position. When the **Chassis** switch is in the **Float** position, the reference of the system chassis will be changed from ground to float. **This will also reduce the stability margin of the system. Use caution when operating with a floating ground. Follow the directions for output connections as required by the Standard.**
5. Make sure the breaker/power switches on all of the amplifier modules and 3110A controller are in the ON position. Make sure the Gain control on the Master amplifier module is fully clockwise.
6. Turn the System Power switch clockwise to turn the DSR 100 system ON.
7. Wait for the 3110A software to load (loading will take up to 30 seconds). Then open the on-screen Help system for help with System Calibration and Operation.
8. **Note:** When using this configuration, total voltage should be limited to 20V or less (40V or less when testing 48V systems) and the maximum current will be limited to the maximum capacity of the DSR 100 system.

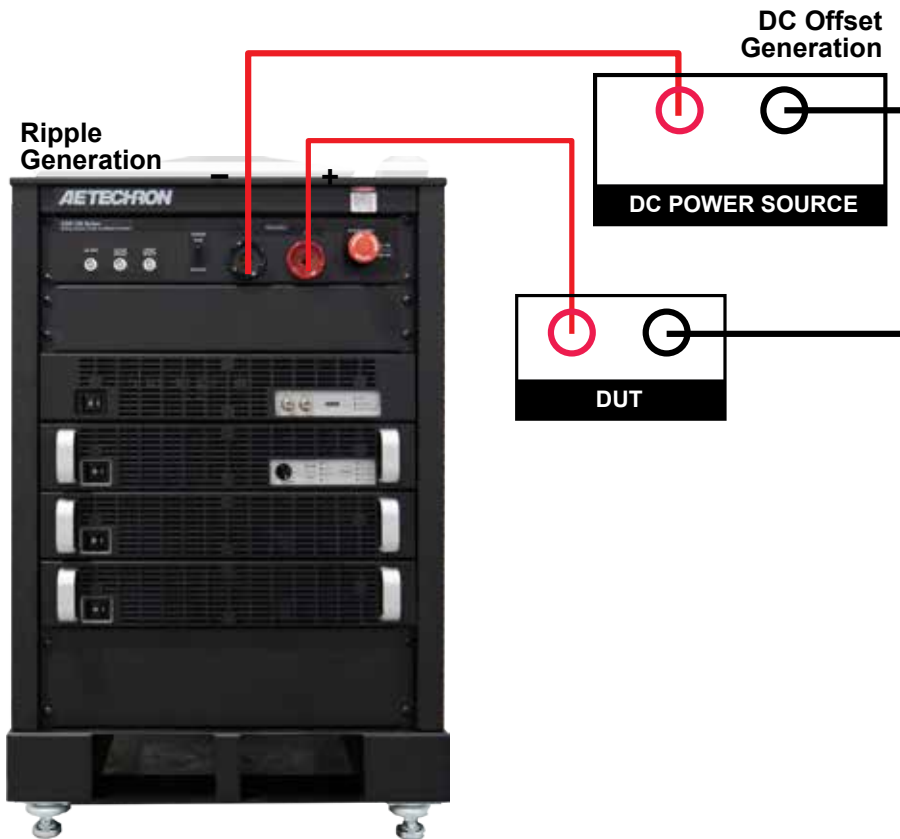

Figure 4.1 – Connections for Testing to ISO 16750-2 Section 4.8.

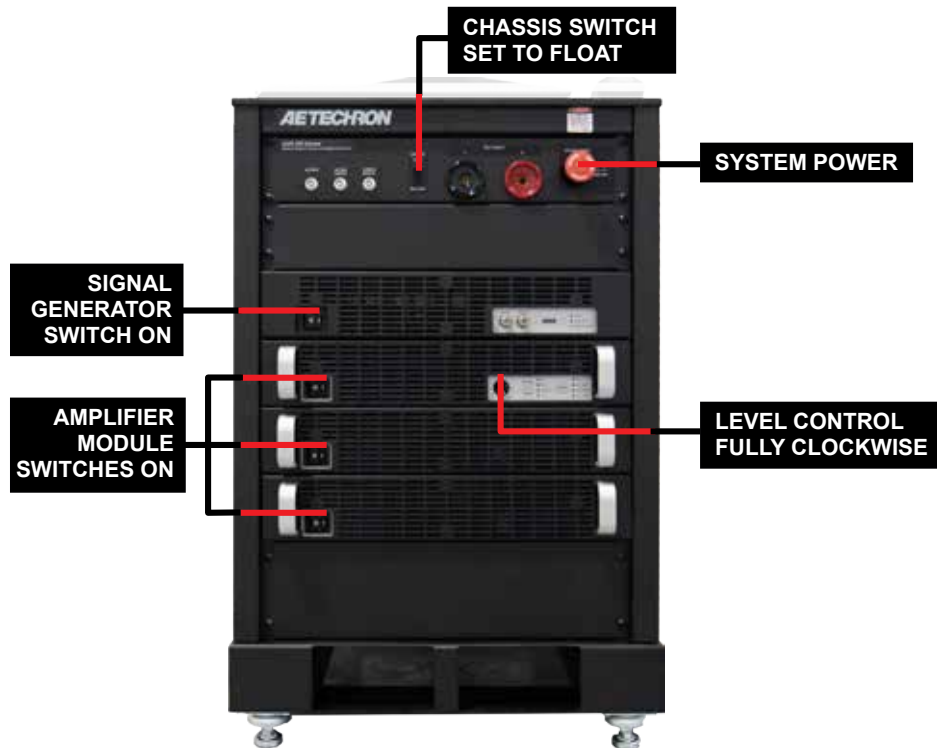

Figure 4.2 – Locations of Controls for ISO 16750-2 Section 4.8 Testing

4.2 Configure for Low-Voltage Testing

Standards Tests having a maximum voltage of less than 30V may require an increase in the signal-to-noise performance of the DSR 100 system in order to achieve accurate results. This can be achieved by lowering the DSR 100 system’s gain. Only a few test sequences will require use of this configuration. **NOTE: When using this configuration, the DSR 100’s system gain will be 5.**

4.2.1 Setup Procedure

Complete the following steps to configure and connect the DSR 100 system and other required equipment.

- 1. Adjust the Master Amplifier Module’s Signal Input Cable:** Open the system’s access door located on the back of the unit. Find the cable connected from the 3110A’s DB25 connector to the Master Amplifier Module’s balanced (WECO) signal input connector. The cable’s WECO connector is marked with the number “20”. You will see that the cable has a second, unattached WECO connector marked with the number “40”. See **Figure 4.3**.

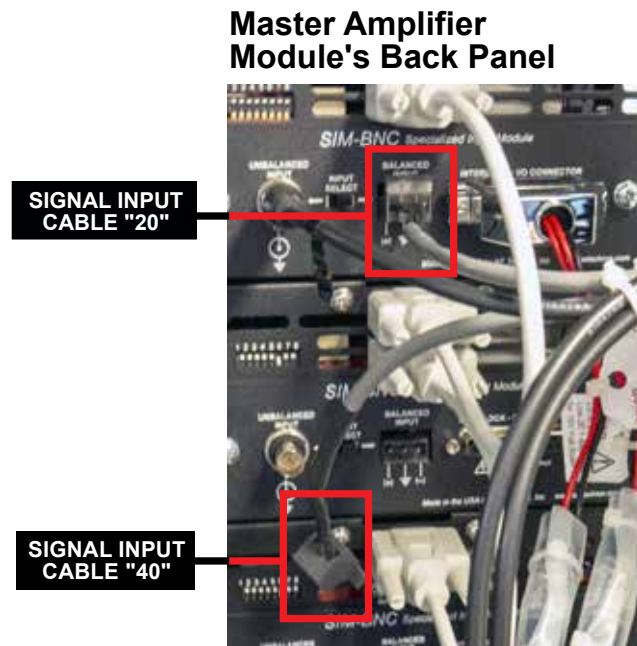

Figure 4.3 – Switching the Signal Input Cable on the Master Amplifier Module’s Back Panel



Figure 4.4 – Connections for Low-Voltage Testing

Unplug the cable’s WECO connector marked “20” and plug the cable’s WECO connector marked “40” in its place. This change will lower the system’s gain from 10 to 5. Securely close the unit’s back access door.

- 2. Connect 3110A Accessories:** If not already connected, follow the instructions in the **System Setup** section of this manual to connect the 3110A accessories.
- 3. Connect the Outputs:** Using the supplied pin-plug connectors and wiring appropriate for your application, connect from the DSR 100’s positive and negative test supply connectors to the device under test. See **Figure 4.4**.

4.2.2 Startup Procedure:

Complete the following to enable the DSR 100 system: Refer to **Figure 4.5** for control locations.

1. Make sure the Chassis switch is in the Grounded position.
2. Make sure the breaker/power switches on all of the amplifier modules are on the ON position.

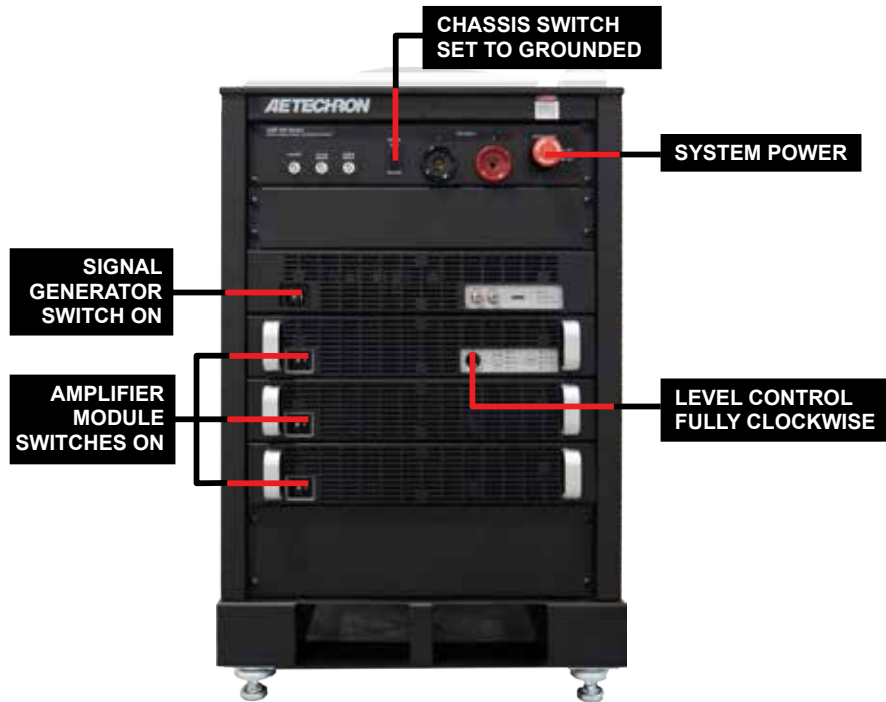

Figure 4.5 – Locations of Controls for Low-Voltage Testing

3. Make sure the power switch on the 3110A controller is in the ON position.
4. Make sure the Gain control on the amplifier module is fully clockwise.
5. Turn the System Power switch clockwise to turn the DSR system ON.

4.3 Using an External Signal Source

This application uses an external signal source and the DSR system’s internal amplifier system.

NOTE: When using this configuration, the DSR 100’s system gain will be 20. To configure the DSR 100 system with a gain of 6 to perform low-voltage testing, see the note at the end of this section.

4.3.1 Setup Procedure

Complete the following steps to connect the DSR 100 system and other required equipment.

1. **Connect 3110A Accessories:** If not already connected, follow the instructions in the **System Setup** section of this manual to connect the 3110A accessories.
2. **Connect the Signal Source:** Use a BNC cable to connect from the signal output con-

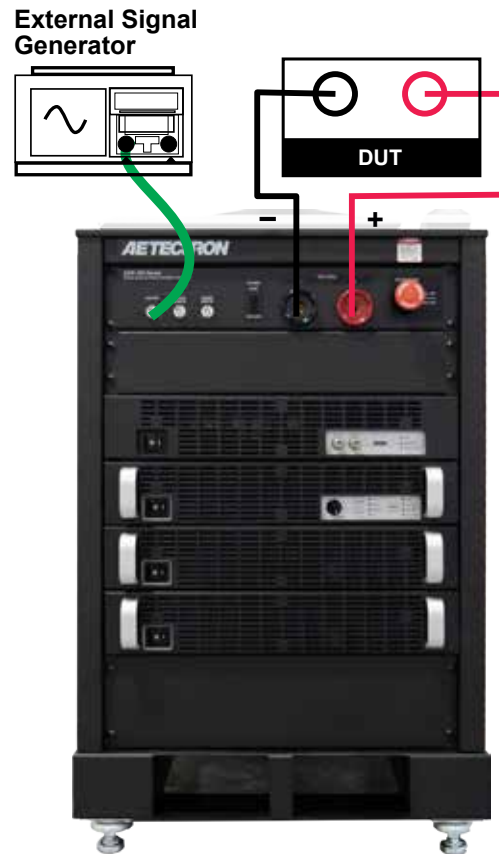

Figure 4.6 – Connections for External Signal Source Use

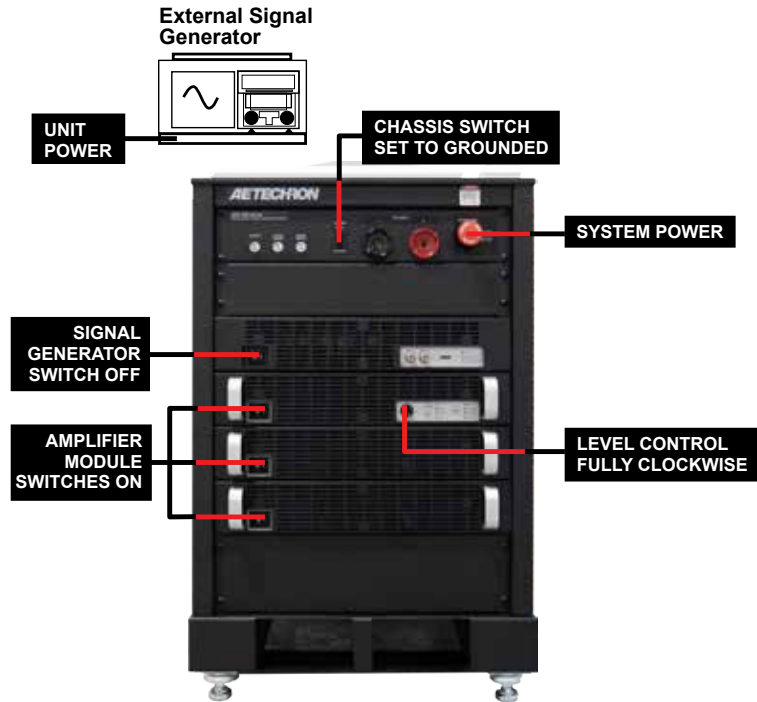

Figure 4.7 – Locations of Controls for Operation with an External Signal Source

necter on your external signal source to the DSR system’s BNC connector labeled Aux Input. See **Figure 4.6**.

3. **Connect the Outputs:** Using the supplied pin-plug connectors and wiring appropriate for your application, connect from the DSR 100’s positive and negative test supply connectors to the device under test. See **Figure 4.6**.

4.3.2 Startup Procedure:

Complete the following to enable the DSR 100 system: Refer to **Figure 4.7** for control locations.

1. Make sure the Chassis switch is in the Grounded position.
2. Make sure the breaker/power switches on all of the amplifier modules are in the ON position.
3. Make sure the power switch on the 3110A controller is in the OFF position.
4. Make sure the Gain control on the amplifier module is fully clockwise.
5. Twist the System Power switch to turn the DSR system ON.
6. Turn your external signal source ON and enable your desired signal. Consult the manual of your external signal source, if needed, for

instructions on operating the unit.

NOTE: To perform low-voltage testing using an external signal generator, the DSR 100 system’s gain setting must be changed. This is done by configuring the Master amplifier module using the following procedure.

Configure the Master Amplifier Module DIP Switches:

1. Open the system’s access door located on the back of the unit.
2. Find the bank of DIP switches on the back of the Master amplifier module and set **DIP switch #4** to the DOWN position. See **Figure 4.8**.

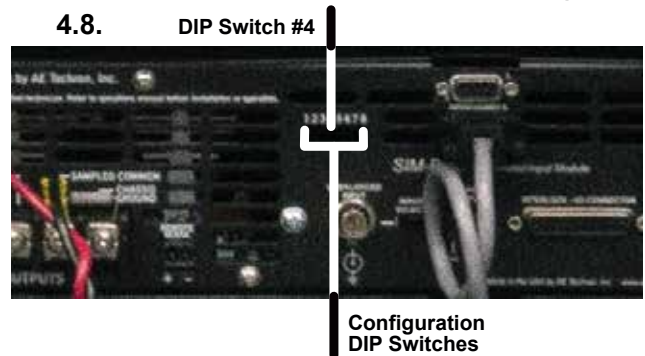

Figure 4.8 – Location of DIP Switch #4 on the Master Amplifier Module



Figure 4.9 – Connections for External Amplifier Use

3. Securely close the system’s access door.
4. Complete the steps for operation using an external signal source.

4.4 Using an External Amplifier

This application uses an external amplifier and the DSR system’s internal waveform generator.

NOTE: Consult your amplifier specifications to determine the system gain.

4.4.1 Setup Procedure

Complete the following steps to connect the DSR 100 system and other required equipment.

1. **Connect 3110A Accessories:** If not already connected, follow the instructions in the **System Setup** section of this manual to connect the 3110A accessories.
2. **Connect External Amplifier:** Use a BNC cable to connect from the BNC connector labeled Signal Out located on the front panel of the 3110A to the signal input connector on the external amplifier. See **Figure 4.9**.

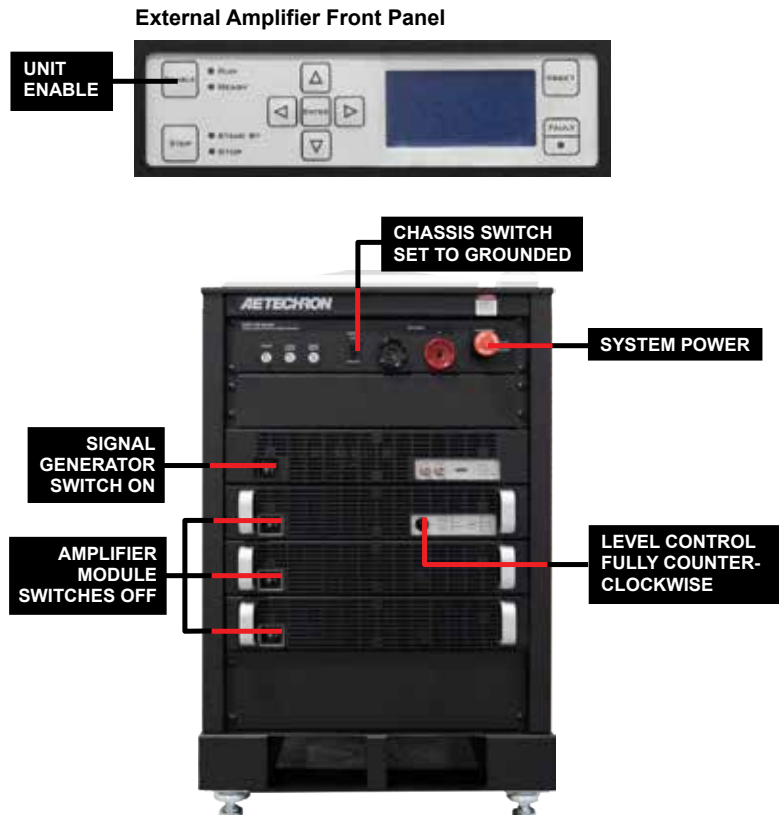

Figure 4.10 – Locations of Controls for Operation with an External Amplifier

3. **Connect the Outputs:** Using the supplied Anderson connectors and wiring appropriate for your application, connect from the external amplifier's positive and negative output connectors to the device under test. See **Figure 4.9**.

4.4.2 Startup Procedure:

Complete the following to enable the DSR 100-25 system: Refer to **Figure 4.10** for control locations.

1. Use the monitor's power switch (last button on the right) to turn on the monitor.
2. Make sure the Chassis switch is in the Grounded position.
3. Make sure the breaker/power switch on the amplifier module is in the OFF position.
4. Make sure the power switch on the 3110A controller is in the ON position.
5. Make sure the Gain control on the amplifier module is fully counter-clockwise.
6. Twist the System Power switch to turn the DSR system ON.
7. Turn your external amplifier ON. Consult the manual of your external amplifier, if needed, for instructions on operating the unit.
8. Wait for the 3110A software to load (loading will take up to 30 seconds). Then open the on-screen Help system for help with System Calibration and Operation.

5 Maintenance

Simple maintenance can be performed by the user to help keep the equipment operational. The following routine maintenance is designed to prevent problems before they occur. See the “Troubleshooting” section for recommendations for restoring the equipment to operation after an error condition has occurred.

Preventative maintenance is recommended after the first 250 hours of operation, and every three months or 250 hours thereafter. If the equipment environment is dirty or dusty, preventative maintenance should be performed more frequently.

The procedures outlined in this section are directed towards an experienced electronics technician; it assumes that the technician has knowledge of typical electronics safety and maintenance procedures.

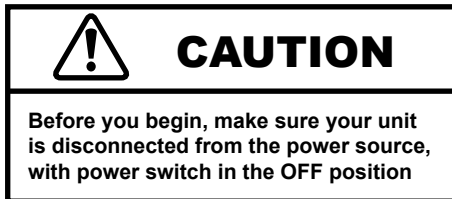

5.1 Clean Filters and Grills on Amplifier Modules

Tools Required

The recommended equipment and supplies needed to perform the functions required for this task are described below.

- Vacuum cleaner
- Damp cloth (use water only or a mild soap diluted in water)

To ensure adequate cooling and maximum efficiency of the internal cooling fans, the front and rear grills on all amplifier modules should be cleaned periodically. To clean the module’s grills and filter, complete the following steps:

1. Turn completely down (counter-clockwise) all level controls and turn the amplifier modules OFF. Turn OFF the DSR 100 system and disconnect it from its power source.
2. Using a vacuum cleaner, vacuum the front ventilation grill and the back ventilation exit grill of all amplifier modules.
3. Remove each front grill by pulling the grill firmly away from the amplifier module.
4. Remove the filter and vacuum. You can also clean the filter using mild soap and water. **IMPORTANT:** Make sure the filter is completely dry before reinstalling in the amplifier module.
5. Using a damp cloth, clean the front and rear ventilation grills. Dry with a clean cloth or allow to air dry. **IMPORTANT:** Grills should be completely dry before plugging in or restarting DSR 100 system.
6. Reinstall the filters and replace the amplifier modules’ front grills.

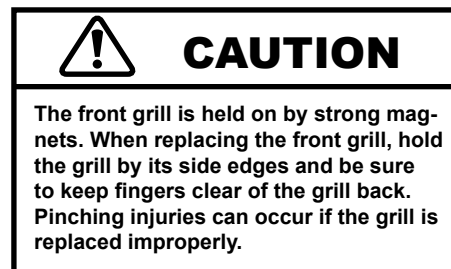

5.2 Clean Cabinet Interior

Tools Required

The recommended equipment and supplies needed to perform the functions required for this task are described below.

- Vacuum cleaner
1. Using a vacuum cleaner, remove any dust that has accumulated within the cabinet interior.
 2. Close the cabinet rear door and restart the test system. Check for any problems such as inoperative fans that might cause overheating.

6 Troubleshooting

If the DSR 100 system is not operating correctly, review the topics below for help with troubleshooting the problem. If the condition or error you are experiencing is not listed below, please contact **AE Techron Technical Support** at 574-295-9495 for additional help.

PROBLEM: The system has no signal output.

A: Check to make sure signal input is being generated using the 3110A Standards Waveform Generator or a stand-alone signal generator.

To see if signal is being generated by the 3110A, access the 3110A SWG software, and check to make sure that output is enabled for the test sequence and that the “Segment Enabled” option is selected for all wave segments.

If using a stand-alone signal generator, check the BNC cable connecting from the signal generator to the AUX INPUT connector on the front panel of the DSR system. Make sure the connections at both ends are secure.

PROBLEM: Cabinet does not power on; no LEDs are lit on the 3110A or any of the amplifier modules.

A: Check that the AC mains are connected to the cabinet and the AC mains is switched on. The Safety Circuit fuse may be blown. Verify continuity of the 1A fuse on the power DIN rail just inside the rear panel at the bottom of the cabinet.

PROBLEM: 3110A unit does not power on.

A: Check the front-panel power switch on the 3110A to make sure the unit is in the ON position.

PROBLEM: Experiencing noise during testing.

A: Adjust the amplifier configuration as detailed in the instructions for Low-Voltage Operation (see the “Applications” section for more information). This configuration adjusts the system gain to improve the system’s signal-to-noise performance. .

PROBLEM: The SWG Windows Remote software will not load or will not connect remotely to the 3110A; instead, an error message indicates a “version mismatch.”

A: The 3110A software and the Windows Remote software versions must match for successful interaction between the two modules. See the topic “Updating the 3110A” in the **3110A Help** files for information about how to install new versions of these modules.

PROBLEM: On one or more of the amplifier modules, no LEDs are lit and/or fans are inoperative.

A: Check the breaker/power switches on all amplifier modules to make sure they are in the ON position. See **Figure 6.1**.

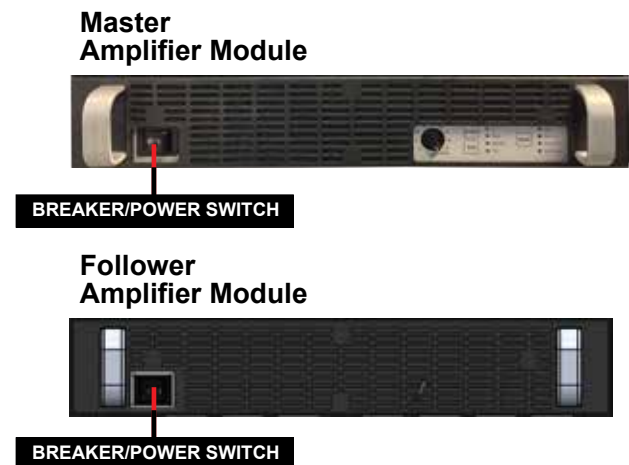

Figure 6.1 – Amplifier Modules’ Breaker/Power Switch Locations

PROBLEM: One or more of the amplifier modules is displaying the Overvoltage Warning message/LED.

A: The amplifier modules will protect themselves from AC mains voltage that is 10% above the 230V rated operating voltage. If this condition occurs, reduce the AC mains voltage to the proper level. When the line voltage condition is corrected, the amplifier modules will automatically reset, and the system will return to Run mode.

If one or more amplifier modules do not automatically reset, the amplifier's three internal transformers may need to be rewired. See the Factory Service information at the end of this section.

PROBLEM: One or more of the amplifier modules is displaying the Overtemp Warning message/LED.

A: One or more amplifier modules may overheat due to one or both of the following conditions: Excessive power requirements and/or inadequate air flow.

An amplifier module will overheat if the required power exceeds the system's capabilities. High duty cycles and low-impedance loads are especially prone to cause overheating. To see if excess power requirements are causing overheating, check the following:

1. Check the "Specifications" section in this manual to verify that your application's requirements fall within the capabilities of this system.
2. Check for faulty output connectors and/or load.
3. Check for undesired DC offset at the output and on the input signal.

If one or more amplifier modules chronically overheats with suitable power and load conditions, then the cabinet or amplifier may not be receiving adequate airflow. Check the following to determine the cause of inadequate airflow:

1. Check air filters for excess dirt and dust. Perform the steps outlined in the "Maintenance" section to clean the amplifier filters and cabinet.
2. Visually inspect fans to assure correct operation while the system is on. Any inoperative, visibly slow, or reverse-spinning fans should be replaced. Please see the Factory Service information at the end of this section.

An OverTemp condition places the unit in Standby mode. If the OverTemp pulse is extremely short, as in the case of defective wiring or switches, the OverTemp pulse may be too brief to observe.

Resetting After Overtemp: To reset the system after an OverTemp has occurred, make sure fans are running in all the amplifier modules, then remove the input signal from the system input. Allow the fans to run for five minutes, and then push the Reset button on the amplifier module(s) reporting the Overtemp Warning to reset the system.

PROBLEM: One or more of the amplifier modules is displaying the Output Device Fault Warning message/LED.

A: The amplifier modules contain protection circuitry that disables the module if an output stage is behaving abnormally. This usually indicates an output transistor has shorted.

To clear the Fault condition, follow these steps:

1. Turn off the signal source.
2. Turn off the system AC mains.
3. Turn AC mains power back on. If the Fault LED doesn't illuminate again, turn the signal source on.
4. If the Fault LED is still illuminated and the Fault condition doesn't clear, return the amplifier module for Factory Service. Please see the Factory Service information at the end of this section.

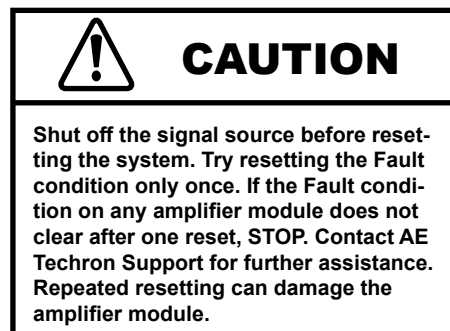

6.1 Factory Service:

If the troubleshooting procedures are unsuccessful, the DSR system may need to be returned for Factory Service. All units under warranty will be serviced free of charge (customer is responsible for one-way shipping charges as well as any custom fees, duties, and/or taxes). Please review the "Warranty." for more information.

All service units must be given Return Authorization Tickets by AE Techron, Inc. before being returned. Return Authorization Tickets can be requested on our website or by contacting our Customer Service Department.

Please take extra care when packaging your unit for repair. It should be returned in its original packaging or a suitable alternative. Replacement packaging materials can be purchased for a nominal fee.

Please send all service units to the following address and be sure to include your Return Authorization Ticket Number on the box.

AE Techron, Inc.

Attn: Service Department / RMA#

2507 Warren Street

Elkhart, IN 46516