

# AETECHRON



## 9205/9305 Operator's Manual

*Wide-Bandwidth, High-Power, Multi-Channel Digital Amplifiers*

---

574.295.9495 | [www.aetechron.com](http://www.aetechron.com)  
2507 Warren Street, Elkhart, IN 46516



## Three-Year, No-Fault Warranty

### SUMMARY OF WARRANTY

**AE TECHRON INC.**, of Elkhart, Indiana (Warrantor) warrants to you, the ORIGINAL COMMERCIAL PURCHASER and ANY SUBSEQUENT OWNER of each NEW **AE TECHRON INC. product, for a period of three (3) years from the date of purchase, by the original purchaser (warranty period) that the product is free of defects in materials and workmanship and will meet or exceed all advertised specifications for such a product. We further warrant the new AE Techron product regardless of the reason for failure, except as excluded in the Warranty.**

### ITEMS EXCLUDED FROM WARRANTY

This AE Techron Warranty is in effect only for failure of a new AE Techron product which occurred within the Warranty Period. It does not cover any product which has been damaged because of any intentional misuse, or loss which is covered under any of your insurance contracts. This warranty does not extend to any product on which the serial number has been defaced, altered, or removed. It does not cover damage to loads or any other products or accessories resulting from **AE TECHRON INC.** product failure. It does not cover defects or damage caused by the use of unauthorized modifications, accessories, parts, or service.

### WHAT WE WILL DO

We will remedy any defect, regardless of the reason for failure (except as excluded), by repair or replacement, at our sole discretion. Warranty work can only be performed at our authorized service centers or at our factory.

Expenses in remedying the defect will be borne by **AE TECHRON INC.**, including one-way surface freight shipping costs within the United States. (Purchaser must bear the expense of shipping the product between any foreign country and the port of entry in the United States and all taxes, duties, and other customs fees for such foreign shipments.)

### HOW TO OBTAIN WARRANTY SERVICE

When you notify us or one of our authorized service centers of your need for warranty service, you will receive an authorization to return the product for service. All components must be shipped in a factory pack or equivalent which, if needed, may be obtained

from us for a nominal charge. We will take corrective actions and return the product to you within three weeks of the date of receipt of the defective product, or will make available to you a product of equal or better performance on temporary loan until your product can be repaired or replaced and returned to you. If the repairs made by us are not satisfactory, notify us immediately.

### DISCLAIMER OF CONSEQUENTIAL AND INCIDENTAL DAMAGES

You are not entitled to recover from us any consequential or incidental damages resulting from any defect in our product. This includes any damage to another product or products resulting from such a defect.

### WARRANTY ALTERATIONS

No person has the authority to enlarge, amend, or modify this warranty. The warranty is not extended by the length of time for which you are deprived of the use of this product. Repairs and replacement parts provided under the terms of this warranty shall carry only the unexpired portion of this warranty.

### DESIGN CHANGES

We reserve the right to change the design of any product from time to time without notice and with no obligation to make corresponding changes in products previously manufactured.

### LEGAL REMEDIES OF PURCHASER

There is no warranty that extends beyond the terms hereof. This written warranty is given in lieu of any oral or implied warranties not contained herein. We disclaim all implied warranties, including, without limitation, any warranties of merchantability or fitness for a particular purpose. No action to enforce this Warranty shall be commenced later than ninety (90) days after expiration of the warranty period. This statement of warranty supersedes any others contained in this manual for AE Techron products.

### **AE TECHRON INC.**

#### **Customer Service Department**

2507 Warren St. Elkhart, IN, 46516, U.S.A.  
(574) 295-9495  
www.aetechron.com

# Contents

<b>1</b>	<b>Introduction</b>	<b>5</b>
1.1	Features	5
<b>2</b>	<b>Amplifier Unpacking and Installation</b>	<b>6</b>
2.1	Safety First	6
2.2	Unpacking	6
2.3	Installation	6
<b>3</b>	<b>Connections and Startup</b>	<b>7</b>
3.1	Connecting the Load	7
3.2	Connecting the Input Signal	7
3.3	Optional Controls and Connectors	8
3.4	Connecting the AC Supply	8
<b>4</b>	<b>Amplifier Operation</b>	<b>10</b>
4.1	Front-Panel Controls and Indicators	10
4.2	Back-Panel Controls & Connectors	11
<b>5</b>	<b>Advanced Configuration</b>	<b>13</b>
5.1	DIP Switch Configurations	13
5.2	Custom Compensation	16
<b>6</b>	<b>Applications</b>	<b>17</b>
6.1	Emergency Standby Switch or Safety Interlock	17
6.2	Controlled-Voltage vs. Controlled-Current Modes of Operation	17
6.3	Driving Reactive Loads	20
<b>7</b>	<b>Maintenance</b>	<b>21</b>
7.1	Clean Amplifier Filter and Grills	21
<b>8</b>	<b>Troubleshooting</b>	<b>22</b>
8.1	Introduction & Precautions	22
8.2	No Signal	22
8.3	No LEDs Illuminated	22
8.4	Over/Under Line LED Lit	22
8.5	Run/Standby LED Remains Amber	22
8.6	Amplifier Overheats (Over Temp Fault Condition)	22
8.7	Fault LED is Illuminated	23
8.8	Factory Service	23



Figure 1.1 – 9205 Front Panel

## 1 Introduction

Congratulations on your purchase of a 9205 or 9305 digital power amplifier. 9205/9305 amplifiers are 200Vp, DC-to-250 kHz capable amplifiers that offer a unique combination of switch-mode efficiency and linear-amplifier-like fidelity in a compact, portable package. They are able to drive virtually any type of load without a reduction in rated power, while maintaining low distortion and low DC drift.

9205/9305 amplifiers are a great choice when available AC Mains power is limited or may change. The 9205/9305 amplifier couples an 85% operating efficiency with a universal, 100V-to-250V power supply with PFC (power factor correction). This highly efficient supply can draw up to 30% more power from a given-size AC Mains breaker while putting less noise back on the AC mains.

Combined, these features permit a 9205/9305 amplifier to produce up to 2 kW output when connected to a 20A, 120V mains supply and up to 5 kW from 230V or 240V sources. Plus, they can move seamlessly from lab to factory since they can be powered from any normal, single-phase, AC Mains supply.

With a slew rate of up to 150 V/ $\mu$ s and a minimum drop/rise time of 7 $\mu$ s, 9205/9305 amplifiers are fast enough to meet the surge and dropout requirements of many current EMC test standards.

9205/9305 amplifiers are available in two- and three-channel versions, with all channels drawing power from the amplifier's common power supply. This design allows power to shift dynamically between channels during operation, so up to 4500 watts of the power supply's potential 5000 watts can be available at any given moment for use by any single channel. This dynamic power capability makes the 9205/9305 amplifier able to perform like a much more powerful amplifier, making it well-suited for applications that have intermittent power

Performance Overview	
Bandwidth	DC - 250 kHz
Minimum Drop/Rise Time	7 $\mu$ s
Slew Rate	Up to 150 V/ $\mu$ s
Max Voltage	200 V <sub>p</sub>
Max Current	Up to 50 A <sub>p</sub> per channel
Distortion	<0.1% at 1 kHz below clip
Max Long-Term Power	5.0 kW

demands for each channel over time, such as MRI systems, multi-channel positioning systems, or multi-element sonar.

Low THD+N and IMD distortion and low DC drift make 9205/9305 amplifiers ideal for many industrial multi-channel applications. Because the 9205/9305 amplifier's outputs are ground-referenced, they can be used to create three-phase, wide-bandwidth voltage sources.

Altogether, 9205/9305 amplifiers are a great solution for a wide range of high-current, low-voltage, low-noise applications that require wide bandwidth and the ability to drive reactive or widely varying load impedances.

### Features

- Available in 2- or 3-channel versions
- Operate as a voltage-controlled voltage source or voltage-controlled current source.
- Four-quadrant operation.
- Adjustable gain.
- Stable when driving highly capacitive loads.
- User-selectable current limit to protect fragile DUTs or where specified in a Standard.
- DC enabled or DC blocked and DC Servo (for driving transformer-coupled loads or coils).



Figure 2.1 – 9305 Back Panel

## 2 Amplifier Unpacking and Installation

9205/9305 amplifiers are precision instruments that can be dangerous if not handled properly. Lethal voltages are present in both the AC input supply and the output of the amplifiers. For this reason, safety should be your primary concern when you setup and operate your amplifier.

### 2.1 Safety First

Throughout this manual special emphasis is placed on good safety practices. The following graphics are used to highlight certain topics that require extra precaution.

	<b>WARNING</b>
<p><b>WARNING</b> alerts you to hazards that could result in severe injury or death. Note the explanation of the hazard and the instructions for avoiding it.</p>	

	<b>CAUTION</b>
<p><b>CAUTION</b> indicates hazards that could result in potential injury or equipment or property damage. Once again, note the explanation of the hazard and the instructions for avoiding it.</p>	

### 2.2 Unpacking

All amplifiers are tested and inspected for damage before leaving the factory. Carefully unpack and inspect the amplifier for damage. **Please note any damage for future reference and notify the shipping company immediately if damage is found.** Also, please save the shipping carton and

materials as evidence of damage and/or for returning the amplifier for repair.

### 2.3 Installation

The 9205/9305 amplifier is packaged in a rugged powder-coated chassis. This chassis is 2U (rack units) tall, and has rack “ears” on each side of the front panel for mounting to a standard EIA (Electronic Industries Association) rack. Use standard rack mounting hardware to mount the amplifier. Use nylon washers if you wish to protect the powder-coat finish on the front of the amplifier.

Optionally, the amplifier can be placed on a bench top; please keep in mind that the protective powder-coating can be scratched when placed on other equipment or on a bench top, especially when there is dirt present.

Allow ample space on the sides and especially the back of the amplifier for heated air to escape. The amplifier should be mounted in a rack that is adequately ventilated and not sealed. Likewise, the front of the amplifier should be unobstructed to allow cool air to enter the amplifier.

	<b>CAUTION</b>
<p><b>Do not operate the amplifier in a small sealed chamber of any kind. Improper operations and overheating will result.</b></p>	

### 3 Connections and Startup

This section details the wiring and startup procedures for a 9205/9305 amplifier operating in Controlled-Voltage mode (factory default). Before connecting the amplifier inputs and outputs, make sure AC power is disconnected.

#### Testing Before Controlled-Current Operation

**IMPORTANT:** If your application requires Controlled Current operation, the 9205/9305 amplifier first should be wired and tested in Controlled-Voltage mode to verify that the amplifier and input signal are operating correctly. Once proper operation is confirmed, refer to the **Applications** section of this manual for instructions on configuring and operating your amplifier in Controlled-Current mode.

#### 3.1 Connecting the Load

##### 3.1.1 Preparation and Cautions

**Before connecting the amplifier, make sure the AC power is disconnected.**

Always use the appropriate wire size and insulation for the maximum current and voltage expected at the output. Never connect the output of the amplifier to any other model amplifier, power supply, signal source, or other inappropriate load; fire can result.

## WARNING

---

**ELECTRIC SHOCK HAZARD.**  
Output potentials can be lethal. Output cover must remain installed at all times to protect against HAZARDOUS LIVE VOLTAGES

##### 3.1.2 Output Connections

Connection to the outputs of the amplifier is to high-current, two-terminal barrier blocks. Two sets of output connectors are provided on the 9205 back panel, and three sets are provided on the 9305 back panel. Wires terminated with #10 spade or ring terminals are recommended when connecting to the output terminals. Connect the load for each channel across the terminals marked “+” (positive) and “-” (negative/ground). The nega-

tive terminals also can be connected to an external ground point such as the rack chassis, if desired. See **Figure 3.1**.

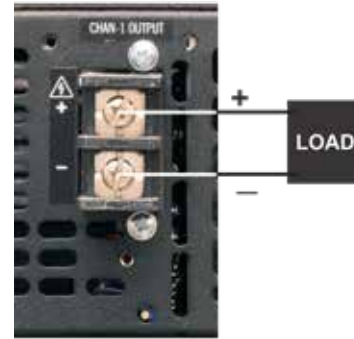

Figure 3.1 – Connecting the Load

Be sure to install the output safety covers after wiring the output connections. See **Figure 3.2**.



Figure 3.2 – Output Safety Cover

#### 3.2 Connecting the Input Signal

An unbalanced BNC connector for each channel is provided on the amplifier back panel for signal input. Connect your input signal source to each connector as shown in **Figure 3.3**. Use cables

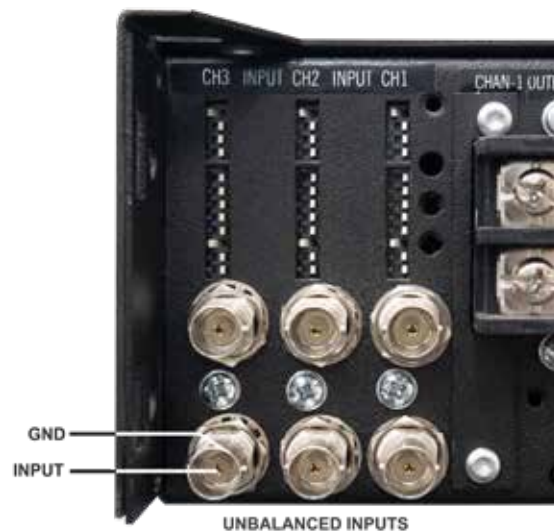

Figure 3.3 – Wiring for Input Connectors

that are high quality and shielded to minimize noise and to guard against possible feedback.

### 3.3 Optional Controls and Connectors

The following controls and connectors are provided on the amplifier back panel to allow for additional monitoring, configuration and control of the amplifier output.

#### 3.3.1 Current Monitor Connectors

Unbalanced BNC ports are provided on the amplifier back panel, one for each channel, to allow for connection to current monitoring equipment. The current monitor output is  $1V = 20A$ .

#### 3.3.2 DIP Switches

DIP switches provided on the amplifier back panel can be used to enable features or configure the amplifier for special applications. See the **Advanced Configuration** section of this manual for more information. Before operating the amplifier, check to make sure all DIP switches are set as intended.

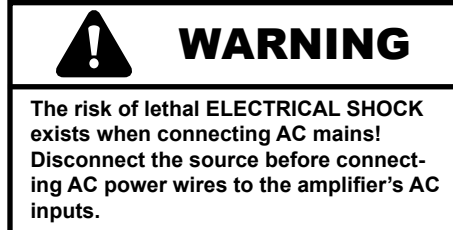

### 3.4 Connecting the AC Supply

#### 3.4.1 Disconnect and Inlet Wiring Protection

A safety disconnect device for the AC mains input must be installed so that it is both nearby and accessible to the operator. The disconnect must be clearly labeled.

Inlet wiring must support the rated current.

The amplifier must be protected by fuses or circuit breakers that protect the power inlet wiring with a maximum rating of no more than 30A.

#### 3.4.2 AC Inlet Connections

Always operate the amplifier from the proper AC mains. 9205/9305 amplifiers require single-phase, 50-60 Hz, 100-250 VAC, at 30A with no more than  $\pm 10\%$  variance above or below the line voltage. The amplifier will not operate properly outside these limits.

Connect protective grounding terminal to AC mains ground before turning on power to prevent electric shock hazard.

Do not disconnect or disable the protective grounding connection. Doing so causes a potential electrical shock hazard.

Connect the AC supply to the three-terminal barrier strip located on the amplifier back panel (see **Figure 3.5**).

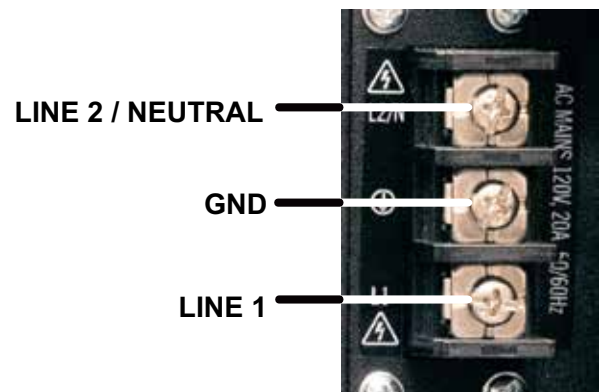

Figure 3.5 – AC Mains Barrier Strip Wiring



### **Start-up Procedure**

1. Turn down the level of your signal source on each channel being utilized.
2. Press the front-panel Standby-Run switch to the Run position to energize the amplifier.
3. Wait until the Run/Standby indicator turns solid green on each channel being operated.
4. For each channel being operated, adjust your input signal level to achieve the desired output level.

## 4 Amplifier Operation

### 4.1 Front-Panel Controls and Indicators

This section provides an overview of Front-Panel controls and indicators found on the 9205/9305 amplifier. Refer to **Figure 4.1** for component locations.

#### 4.1.1 Standby-Run Switch

The Standby-Run switch controls the power to the amplifier's high-voltage transformers. **Switch to the Run position (right) to energize the amplifier. Switch to the Standby position (left) to remove power from the high-voltage transformers and place the amplifier in Standby mode.**

#### 4.1.2 Run/Standby Indicator (one per channel)

**Run mode:** The indicator will be lit solid green. The amplifier's high-voltage transformers are energized and the unit will amplify the input signal to that channel.

**Standby mode:** The indicator will be lit solid amber. The amplifier will be placed in Standby when one of the following conditions occurs:

1. Power Supply condition
2. Overtemp condition
3. Over Current condition
4. The user sets the front-panel Standby-Run switch to the Standby (left) position.

In Standby mode, the amplifier's low-voltage power supply is energized but the high-voltage power supply is not.

To release the amplifier from Standby mode:

1. **Power Supply condition:** If the amplifier's Power Supply indicator is lit, the amplifier is trying to absorb too much power. Turn the amplifier's front Standby-Run switch to the Standby position, and then either adjust the input signal(s) or the load(s) to lower the power being returned to the amplifier. Turn the Standby-Run switch to the Run position to resume amplifier operation.

If both the Power Supply and Overload indicators are lit, too much power is being drawn from the power supply. This condition often occurs due to high-current operation into a very small load. Turn the amplifier's front Standby-Run switch to the Standby position, then reduce the input signal(s) or increase the impedance of the load(s) to lower the current requirements. Turn the Standby-Run switch to the Run position to resume amplifier operation.

2. **Overtemp condition:** This condition often occurs when the required power exceeds the amplifier's capabilities. Remove the input signal(s) from the amplifier and leave the amplifier with the Standby-Run switch in the Run position and with the fans operating to cool the amplifier. When the amplifier's internal temperature drops to less than 100°C, the amplifier will resume operation.

If the amplifier continues to overheat while operating within the amplifier's capabilities, the amplifier may require maintenance. See the **Troubleshooting** section for more information.



Figure 4.1 – 9305 Front Panel Controls and Indicators

3. **Over Current condition:** This condition can occur when a very high current is being drawn from the amplifier. Lower the operating level of the amplifier, then turn the amplifier's front-panel Standby-Run switch to Standby and then back to Run to reset the amplifier. If the fault condition recurs or does not clear, the amplifier may require servicing. See the **Troubleshooting** section for more information.
4. **Standby-Run switch pressed:** When the amplifier is operating (Run mode), setting the front-panel Standby-Run switch to the Standby position (left) will place the amplifier in Standby mode. Set the switch to Run (right) to release the amplifier from Standby and return the amplifier to Run mode.

#### **4.1.3 Signal / Overload Indicators (one per channel)**

**Signal Presence:** When an input signal is presented at an active signal input on the amplifier at a level greater than 0.5V, the Signal/Overload indicator will light solid green.

**Overload (clipping):** The indicator will flash amber intermittently. When the indicator flashes amber, this indicates that the output of the system could not follow the input signal due to voltage or current limits. The amber Overload indicator will begin flashing when distortion is greater than 0.1%.

#### **4.1.4 Power Supply Indicators (one per channel)**

This amber indicator will illuminate, and the amplifier will be placed in Standby under two conditions:

- The amplifier is sinking too much power. Under these conditions, typically only the Power Supply indicator will be lit.
- Too much power is being drawn from the power supply. This condition often occurs due to high-current operation into a very small load. Under these conditions, both the Power Supply and the Overload indicators will typically be lit.

To remove the amplifier from Standby, first switch the amplifier's front Standby-Run switch to the Standby position. Then adjust the input signal or the load to lower the power requirements or the power being returned to the amplifier.

Turn the Standby-Run switch to the Run position to resume amplifier operation. If the Power Supply indicator does not turn off or if the amplifier does not return from Standby, the amplifier may require servicing. See the **Troubleshooting** section for more information.

#### **4.1.5 Overtemp / Over Current Indicator (one per channel)**

**Overtemp Condition:** The amplifier monitors the temperature inside the high-voltage power supply and in the output stage heat sinks. The Overtemp / Over Current indicator will light amber and the amplifier will be placed in Standby mode when the temperature sensors detect a condition that would damage the amplifier. If the Overtemp pulse is extremely short, as in the case of defective wiring or switches, this indicator may be lit too briefly to observe.

To remove the amplifier from Standby and return it to normal operation after an Overtemp fault has

occurred, make sure the Standby-Run switch is in the Run position and the amplifier fans are running, and then remove the input signal from the amplifier. Allow the fans to run until the amplifier automatically returns to Run mode. See the **Troubleshooting** section for information on identifying and correcting the cause of an Overtemp fault condition.

**Over Current Condition:** The amplifier monitors the current levels produced at the amplifier output. The Overtemp / Over Current indicator will light red and the amplifier will be placed in Standby mode when the current sensors detect operation at the amplifier's peak current level for more than 500 ms. An Over Current condition can occur when the amplifier is operated at high levels into very-low-impedance loads (below 0.25 ohms).

To remove the amplifier from Standby and return it to normal operation after an Over Current fault has occurred, complete the following steps:

1. Turn off the signal source.
2. Set the front-panel Standby-Run switch to the Standby position (left).
3. Turn off the AC mains.
4. Turn AC mains power back on. If the Over Current (red) LED doesn't illuminate again, press the Standby-Run switch to place the amplifier in Run mode and turn the signal source on.
5. If the Over Current LED is still illuminated and the Fault condition doesn't clear, return the

amplifier for Factory Service. See the Factory Service information at the end of the **Troubleshooting** section of this manual.

## 4.2 Back-Panel Controls & Connectors

This section provides an overview of Back-Panel controls and connectors found on the 9205/9305 amplifier. Please refer to **Figure 4.2** for component locations.

**Configuration DIP Switches (one set per channel)** – This set of 12 DIP switches provides various functions and allows the amplifier channel to be configured for special applications. See the **“Advanced Configuration”** section for more information.

**Current Monitor Connectors (one per channel)** – This unbalanced BNC port allows for connection to current monitoring equipment. The current monitor output is  $1V = 20A$ .

**Unbalanced BNC Input Connectors (one per channel)** – This BNC connector provides a standard unbalanced input.

**Output Terminals (one pair per channel)** – Connect output lines from the load to this pair of high-current output terminals using #10 spade or ring terminals.

**AC Power Input** – Three-terminal barrier strip connector.

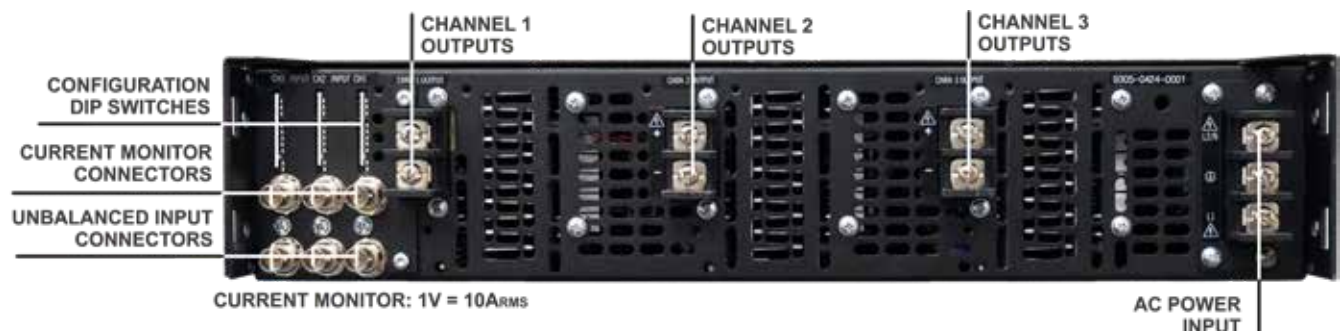

Figure 4.2 – 9305 Back Panel Controls and Connectors

## 5 Advanced Configuration

The 9205/9305 amplifier was designed to offer exceptional versatility in operation. You can choose from a range of field-configurable options, including:

- Enable DC Servo to ensure DC offset remains at zero and safely drive coils and transformers.
- Select Controlled-Current or Controlled-Voltage modes of operation.
- Select between two compensation networks for Controlled Current operation: CC1, designed for loads from 10  $\mu$ H to 500  $\mu$ H; or CC2, designed for loads from 500  $\mu$ H to 2 mH.
- Select DC-coupled or AC-coupled operation.
- Adjust the amplifier gain from 2.5 to 20 in increments of 2.5.
- Limit current output from 15A to 60A in increments of 15A.

### 5.1 DIP Switch Configurations

The 9205/9305 amplifier provides a set of 12 DIP switches per channel located on the amplifier back panel. Most configuration settings for a channel can be made using these DIP switches. See **Figure 5.1** for default DIP switch settings and descriptions.

#### SW#1: DC Servo

The DC Servo function ensures that no DC offset is present at the signal output (-3 dB at 3 Hz). Select DC Servo when driving transformers or other coils. When the DC Servo DIP switch is in the RIGHT position, the DC Servo function is enabled. When this switch is in the LEFT position (default), the DC Servo function is disabled.

### 9205/9305 Default DIP Switch Settings

Red = Default

	OFF	ON		
1			1 DC SERVO	OFF ON
2			2 OPERATION MODE	CC CV
3			3 COMPENSATION NETWORK 2	OFF ON
4			4 COMPENSATION NETWORK 1	OFF ON
5			5 CONTROL CONFIGURATION	FOLLOWER MASTER
6			6 COUPLING	AC DC
7			7 GAIN BIT 3 (MSB)	OFF 10
8			8 GAIN BIT 2	OFF 5
9			9 GAIN BIT 1 (LSB)	OFF 2.5
6			10 <i>ELECTRONIC GAIN MATCHING</i>	OFF ON
7			11 CURRENT LIMIT BIT 1	OFF +25Ap
8			12 CURRENT LIMIT BIT 2	OFF +12.5Ap

ALL OFF = 2.5  
ALL UP = 20

BOTH OFF = 12.5Ap  
BOTH ON = 50Ap

NOTE: *GRAY TEXT INDICATES SWITCH USED FOR FACTORY CONFIGURATION ONLY.*  
ALL BIT SWITCHES ARE ADDITIVE. RIGHT = ON.

Figure 5.1 – Default DIP Switch Settings and Descriptions

## SW#2: Operation Mode

When the Operation Mode DIP switch is in the RIGHT position (default), the amplifier channel will operate in Controlled-Voltage mode, and the channel's output voltage will be controlled by its input voltage signal. When this switch is in the LEFT position, the amplifier channel will operate in Controlled-Current mode, and the channel's output current will be controlled by its input voltage signal.

**IMPORTANT:** Controlled-Current operation requires the use of a compensation network. The 9205/9305 amplifier provides two installed compensation networks for each channel: one network is suitable for loads from 10  $\mu\text{H}$  to 500  $\mu\text{H}$ ; the other is suitable for loads from 500  $\mu\text{H}$  to 2 mH. For more information on Controlled-Current operation, including instructions for selecting the best compensation option for your application, see the topic "Controlled Current Operation" in the **Applications** section of this manual. If neither of the available RC networks is suitable for your application, please contact **AE Techron Technical Support**.

## SW#3: Compensation Network 2

When a channel of the 9205/9305 amplifier is used in Controlled-Current mode, the current control loop is tuned with an RC network. The factory default network (Compensation Network 1) provides 49.9k ohm resistance and 47 nF capacitance and should be used with loads that are 10  $\mu\text{H}$  to 500

$\mu\text{H}$ . If this default network is not adequate for your application and load, the Compensation Network 1 switch can be turned off and the Compensation Network 2 switch can be used to enable a network that provides 80.6k ohm resistance and 220 nF



## CAUTION

In Controlled-Current Mode, the load is part of the amplifier channel's circuit, and the relationship of the load to the amplifier is critical. For proper and safe operation in Controlled-Current mode, you must observe the following guidelines:

1. **Properly attach a load before operating the amplifier channel.**
2. **DO NOT use a blocking capacitor.** The load must have a DC path.
3. **Never leave the load open.** If you feel the load must be fused, which could lead to a potential open circuit, please contact AE Techron Technical Support.
4. **Check to make sure the load has some inductive component.**
5. **Provide appropriate Compensation for the load, using either Compensation Network 1 (SW#4) or Compensation Network 2 (SW#3).** If neither compensation network is adequate for your load, contact **AE Techron Technical Support**.
6. **Turn off the amplifier immediately if oscillation occurs.**

**Failure to follow these guidelines may result in damage to the amplifier or load.**

capacitance and should be used with loads that are 500  $\mu\text{H}$  to 2 mH.

**NOTE:** It is recommended to only use one of the compensation networks at a time. Having SW#3 and SW#4 both on (RIGHT) will likely provide improper compensation for the load, and may result in amplifier instability.

For more information on Controlled-Current operation, including instructions for selecting the best compensation setting for your application, see the topic "Controlled Current Operation" in the **Applications** section of this manual. If neither of the available RC networks is suitable for your application, please contact **AE Techron Technical Support**.

## SW#4: Compensation Network 1

When the 9205/9305 amplifier is used in Controlled-Current mode, the current control loop is tuned with an RC network. The Compensation Network 1 switch enables the factory default RC network. This provides 49.9k ohm resistance and 47 nF capacitance and should be used with loads that are 10  $\mu\text{H}$  to 500  $\mu\text{H}$ . If this default network



## CAUTION

Do not change the setting of the Operation Mode switch while the amplifier is operating (Run mode). Damage to the amplifier or the load can occur. Place the amplifier in Standby mode by pressing the front-panel Standby-Run switch before changing the Operation Mode setting on any channel.

is not adequate for your application and load, the Compensation Network 1 switch can be turned off and the Compensation Network 2 switch can be used to enable a network that provides 80.6k ohm resistance and 220 nF capacitance and should be used with loads that are 500  $\mu$ H to 2 mH.

**NOTE:** It is recommended to only use one of the compensation networks at a time. Having SW#3 and SW#4 both on (RIGHT) will likely provide improper compensation for the load, and may result in amplifier instability.

For more information on Controlled-Current operation, including instructions for selecting the best compensation option for your application, see the topic “Controlled Current Operation” in the **Applications** section of this manual. If neither of the available RC networks is suitable for your application, please contact **AE Techron Technical Support**.

**SW#5: Control Configuration**

Used for factory configuration only.

**SW#6: Coupling**

When the Coupling DIP switch is in the RIGHT position (default), the amplifier channel can receive and amplify both DC and AC signal. When this switch is in the LEFT position, a 30-Hz high-pass filter on the input prevents the transmission of DC signal.

**SW#7 – SW#9: Gain**

The gain for the amplifier channel can be adjusted from 2.5 to 20 in increments of 2.5 using switches 7 through 9. All switches are additive and provide the following values toward the total Gain amount: SW#7 = 10.0, SW#8 = 5.0, SW#9 = 2.5. Refer to **Figure 5.3** for all available gain switch settings.

ON = DIP Switch RIGHT OFF = DIP Switch LEFT			
SW#7	SW#8	SW#9	Gain
ON	ON	ON	20.0
ON	ON	OFF	17.5
ON	OFF	ON	15.0
ON	OFF	OFF	12.5
OFF	ON	ON	10.0
OFF	ON	OFF	7.5
OFF	OFF	ON	5.0
OFF	OFF	OFF	2.5

Figure 5.3 – Gain Switch Configurations

**SW#10: Electronic Gain Matching**

*Used for factory configuration only.*

**SW#11 - #12: Current Limit**

These two switches control the current-limit settings for the amplifier channel. When both switches are in the RIGHT position (default), the amplifier channel's output current is limited to 60A. The current-limit can be lowered in 15A increments by setting one or more of the current limit switches in the LEFT position. Refer to **Figure 5.4** for all available current-limit switch settings.

ON = DIP Switch RIGHT OFF = DIP Switch LEFT		
SW#11	SW#12	Current Limit
ON	ON	50A
ON	OFF	37.5A
OFF	ON	25A
OFF	OFF	12.5A

Figure 5.4 – Current Limit Switch Configurations

**5.2 Custom Compensation**

If you wish to change one of the two standard compensations to a custom compensation, please contact **AE Techron Technical Support** for specific instructions.

## 6 Applications

### 6.1 Controlled-Voltage vs. Controlled-Current Modes of Operation

AE Techron 9205/9305 amplifiers can be field-configured to have one or more channels operate as a **Voltage Amplifier** (Voltage-Controlled Voltage Source) or as a **Transconductance Amplifier** (Voltage-Controlled Current Source). The mode selection is made via the back-panel DIP switch #2. See the **Advanced Configuration** section for more information.

When configured as a **Controlled-Voltage** source (voltage amplifier), the channel will provide an output voltage that is constant and proportional to the control (input) voltage. If the load's impedance changes, the 9205/9305 will seek to maintain this ratio of input to output voltage by increasing or decreasing the current it produces, as long as it is within the amplifier's ability to create the required current. Use this mode if you want the output voltage waveform to be like the input waveform (see **Figure 6.1**).

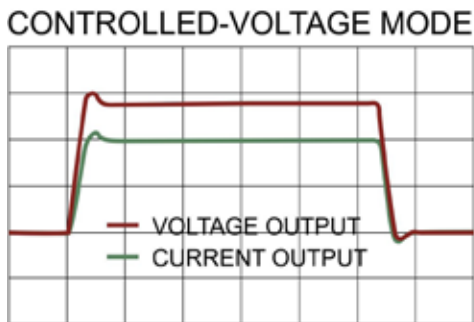

Figure 6.1 – Input to Output Comparison, Controlled-Voltage Operation

Conversely, when configured as a **Controlled-Current** source (transconductance amplifier), the amplifier will provide an output current that is constant and proportional to the control (input) voltage. If the load's impedance changes, the amplifier will seek to maintain this transconductance (ratio of input voltage to output current) by increasing or decreasing the voltage it produces, as long as it is within the amplifier's ability to create the required voltage. Use this mode if you want the output cur-

rent waveform to be like the input waveform (see **Figure 6.2**).

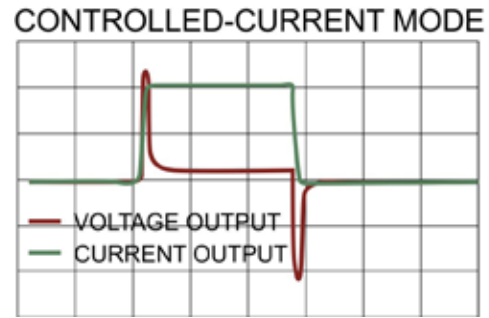

Figure 6.2 – Input to Output Comparison, Controlled-Current Operation

#### 6.1.1 Safety and Operation Considerations for Controlled Current Operation

When an AE Techron amplifier is configured as a Controlled-Current source, care needs to be exercised in its operation. **Any voltage controlled current source should never be turned on without a load, (with some impedance, real or effective) connected to its output terminals.** When asked to operate in this way, any current source (including an AE Techron amplifier) will increase its output voltage in an attempt to drive the requested current into the load. In an open-circuit condition, creating current flow will be impossible. The current source will increase its output voltage until it reaches its voltage limit. This is a potentially dangerous condition for both the AE Techron amplifier and for any user who might come in contact with the amplifier output terminals.

Likewise, operation in Controlled Current mode into a load that is completely resistive is **NOT recommended**. The load must have some inductance for Controlled Current mode to operate correctly.

When operating in Controlled-Current (CC) mode, a compensation circuit is required to ensure accurate output current. Since the load is a critical circuit component in CC mode, the inductive and resistive values of the load will determine the required compensation values.

One of the two compensation settings that can be enabled with DIP switch settings will be sufficient for most applications. If you determine that neither



Compensation Network 1 or Compensation Network 2 will be adequate for your application and load, please contact **AE Techron Technical Support** for additional compensation options.

The following section describes methods for determining proper compensation setting for your application when operating in Controlled-Current mode.

### 6.1.2 Selecting Compensation for CC Operation

One or more channels on 9205/9305 amplifiers can be configured for either Controlled Voltage

(CV) or Controlled Current (CC) mode of operation. When operating the amplifier in Controlled Voltage (CV) mode, compensation is not required. However, when operating in Controlled Current (CC) mode, the channel's load becomes an integral part of the system. In order to ensure system stability and to control available bandwidth, compensation via an RC network is required for CC operation. The following steps will show you how to determine the proper compensation network for your load to allow you to operate your amplifier channel in CC mode safely and effectively.

---

#### STEP 1: Check Amplifier Operation in CV mode.

We recommend that you power-up and enable the amplifier with all channels in Controlled Voltage mode and without attaching any loads before configuring your amplifier channels(s) for Controlled Current operation. This will allow you to verify that each channel and each channel's input signal are operating correctly.

Once this initial check is completed, power down the amplifier, attach your load(s), and, for each channel requiring CC operation, move the back-panel Operation Mode DIP switch (SW#2) to the LEFT position to place the channel in CC mode.

---

#### STEP 2: Determine Required Compensation.

When operating an amplifier channel in Controlled-Current mode, the load becomes an integral part of the system. In order to determine the required compensation for your load, consulting the following table to determine the approximate compensation capacitance (CC) required based on the inductance of your load. Note that these calculations are based on empirical measurements and are approximate.

Load Inductance (L)	Compensation Capacitance (CC)	Compensation Network
10 $\mu$ H to 500 $\mu$ H	47 nF	Network 1
500 $\mu$ H to 2 mH	220 nF	Network 2

**NOTE: Load Resistance (R) is assumed to be <5 ohms.**

**STEP 3: Enable Compensation Network**

If your load inductance is between 10  $\mu$ H and 500  $\mu$ H, and your load resistance is less than 5 ohms, then you can likely use Compensation Network 1 for your application. If your load inductance is between 500  $\mu$ H and 2 mH, and your load resistance is less than 5 ohms, then you can likely use Compensation Network 2 for your application. These compensation networks are enabled when

Compensation Network 1 DIP switch (SW#4) or Compensation Network 2 DIP switch (SW#3) for the amplifier channel is set to the ON (RIGHT) position.

If your load inductance falls outside of these ranges, or if your load resistance is greater than 5 ohms, please contact **AE Techron Technical Support** for assistance.

**STEP 4: Verifying Operation**

**Remember the load(s) you are connecting are a part of the system and the amplifier should not be turned on without a load being connected to every channel configured for CC operation.**

After selecting and enabling your choice of Compensation Networks for each channel selected for CC operation, check to ensure that the Operation Mode DIP switch is set to CC (RIGHT), then power up the amplifier without signal input.

To begin testing a channel configured for CC mode, input a square wave with a frequency of

100 Hz to 1 kHz, or a squared pulse at a low level (typically 0.25 to 2.0 volts). A limited-rise-time, repetitive pulse of low duty cycle is preferred.

Observe the output current through a current monitor or current probe. Look for clean transition edges. The presence of ringing or rounding on the transition edges indicates compensation problems. (See **Figure 6.3.**)

If a change in compensation is necessary, please contact **AE Techron Technical Support** for assistance. **DO NOT** operate your amplifier in Controlled Current mode without proper compensation.

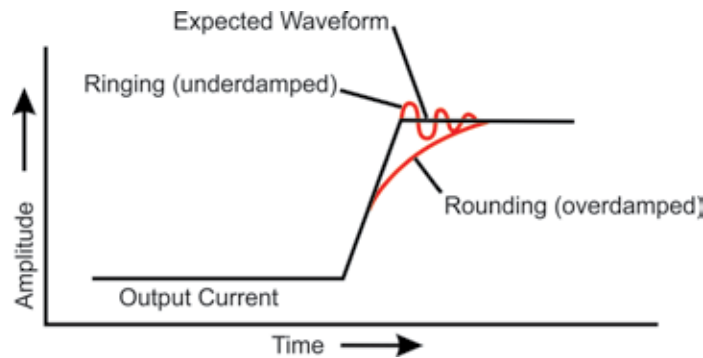

Figure 6.3 – Compensation Effects on Waveform

### 6.2 Driving Reactive Loads

Like all switching amplifiers, 9205/9305 amplifiers are able to reuse the energy returned from reactive loads. Unlike purely resistive loads, loads with some reactance (either capacitive or inductive) will store energy during part of a cycle, and then release some of this energy back later. This energy is transferred back to the load through the amplifier's power supply. This allow the amplifier to deliver continuous apparent power that is up to five times the rated power of the amplifier when driving reactive loads.

### 6.3 Split-Phase Electric Configuration

The 9205 or 9305 amplifier can be configured as a 240V split-phase electric supply, capable of producing 120V or 240V output. To configure your amplifier for this application, complete the following steps:

1. **Configuration:** The default DIP switch settings can be used when configuring the amplifier as a split-phase supply. See **Figure 5.1** for the default DIP switch settings. Note that if your application requires alternate DIP switch settings to enable one or more options, we recommend that the same settings be used for both legs of the supply.



## WARNING

**ELECTRIC SHOCK HAZARD.**  
Output potentials can be lethal. Output cover must remain installed at all times to protect against HAZARDOUS LIVE VOLTAGES

2. **Wiring** (refer to **Figures 6.4** and **6.5**)
  - A. **Before connecting the amplifier, make sure the AC power is disconnected.**

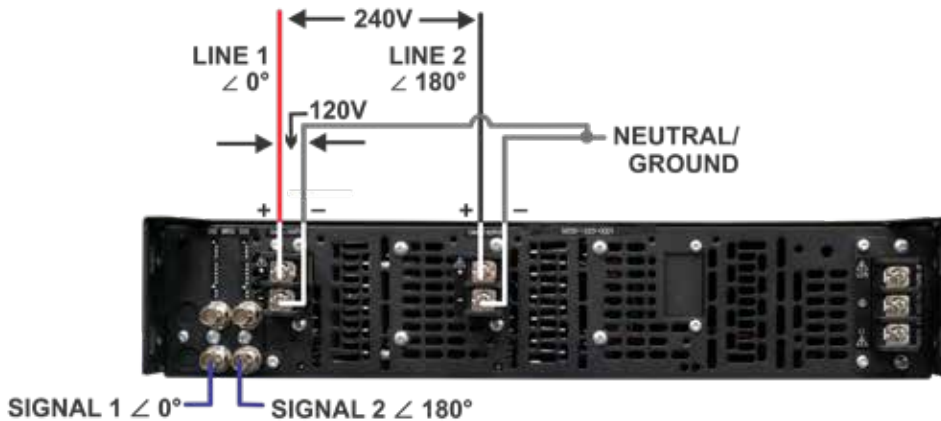

Figure 6.4 – Wiring the 9205 Amplifier as a 240V Split-Phase Electric Supply

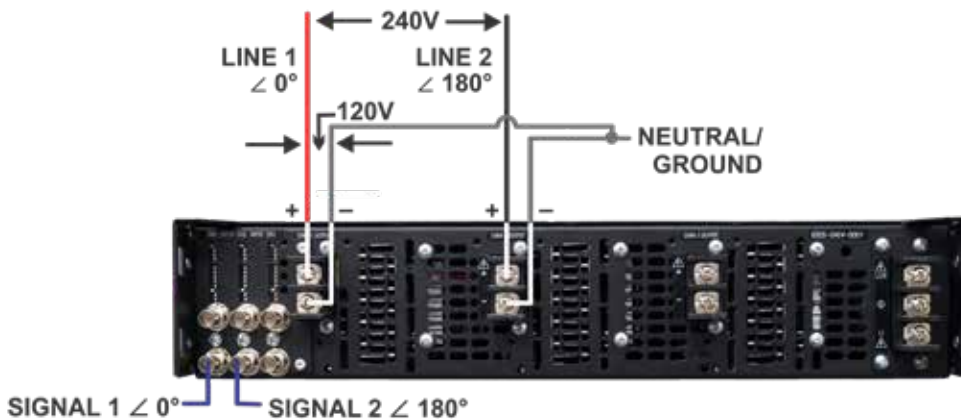

Figure 6.5 – Wiring the 9305 Amplifier as a 240V Split-Phase Electric Supply

- B. **Output Connections:** Using wires terminated with #10 spade or ring terminals, connect the load across the Channel 1 output terminal marked “+” (positive) and the Channel 2 output terminal marked “+” (positive). Connect together the outputs from each channel marked “-” (negative/ground).
- C. Be sure to install the output safety covers after wiring the output connections.
- D. **Input Connections:** Configure your input signal source to produce synced signals with the required phase offsets and at your desired frequency and levels. Connect your input signal sources to the BNC connectors for each channel as shown in **Figures 6.4 and 6.5**.

**6.4 3-Phase Wye (4 wire) Configuration**

The 9305 amplifier can be configured as a 3-phase, Wye electric supply, capable of producing 208V output. To configure your amplifier for this application, complete the following steps:

1. **Configuration:** The default DIP switch settings can be used when configuring the amplifier as a 3-phase supply. See **Figure 5.1** for the default DIP switch settings. Note that if your application requires alternate DIP switch settings to enable one or more options, we recommend that the same settings be used for all legs of the supply.
2. **Wiring** (refer to **Figures 6.6**)
  - A. **Before connecting the amplifier, make sure the AC power is disconnected.**
  - B. **Output Connections:** Using wires terminated with #10 spade or ring terminals, connect the load to the “+” (positive) output terminals for Channel 1, 2, and 3. Connect together the outputs from each channel marked “-” (negative/ground).
  - C. Be sure to install the output safety covers after wiring the output connections.
  - D. **Input Connections:** Configure your input signal source to produce synced signals with the required phase offsets and at your desired frequency and levels. Connect your input signal sources to the BNC connectors for each channel as shown in **Figure 6.6**.

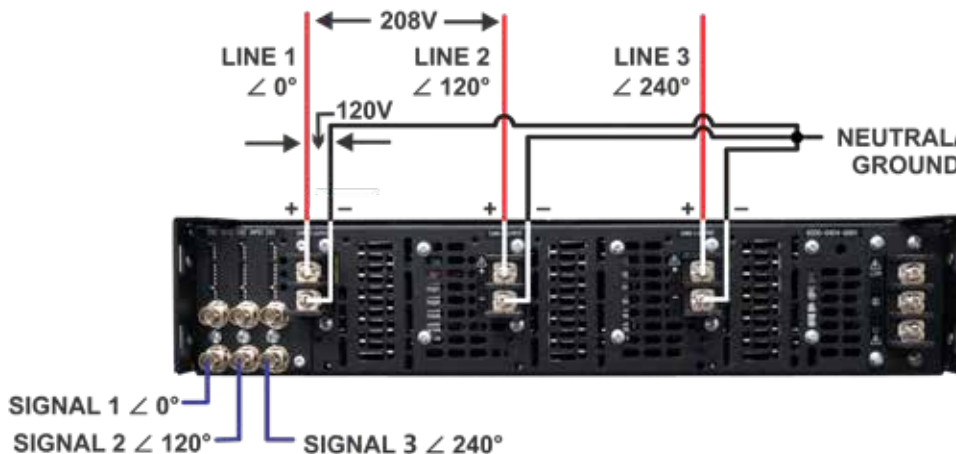
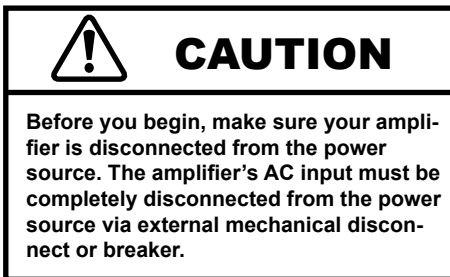

Figure 6.6 – Wiring the 9305 Amplifier as a 3-Phase Wye Electric Supply

## 7 Maintenance

Simple maintenance can be performed by the user to help keep the equipment operational. The following routine maintenance is designed to prevent problems before they occur. See the **Troubleshooting** section, for recommendations for restoring the equipment to operation after an error condition has occurred.

Preventative maintenance is recommended after the first 250 hours of operation, and every three months or 250 hours thereafter. If the equipment environment is dirty or dusty, preventative maintenance should be performed more frequently.



### 7.1 Clean Amplifier Filter and Grills

#### 7.1.1 Tools Required

The recommended equipment and supplies needed to perform the functions required for this task are described as follows.

- Vacuum cleaner
- Damp cloth (use water only or a mild soap diluted in water)

To ensure adequate cooling and maximum efficiency of the internal cooling fans, the amplifier's front and rear grills should be cleaned periodically. To clean the amplifier grills and filter, complete the following steps:

1. Disconnect the amplifier from its power source via external mechanical disconnect or breaker.
2. The front grill is secured to the amplifier front panel by magnets. Pull out on the grill to release it from the front panel.
3. Remove the filter located behind the front grill.
4. Using a vacuum cleaner, vacuum the front ventilation grill, the grill filter, and the back ventilation exit grill.
5. Using a damp cloth, clean the amplifier front panel and the rear ventilation grills. Also use the damp cloth to clean the front grill and filter. If necessary, these can be immersed in warm, soapy water.
6. Dry the front panel, filter, and grills with a clean cloth or allow to air dry. **IMPORTANT: All parts should be completely dry before reconnecting or restarting the amplifier.**
7. Reinstall the filter and replace the amplifier front grill.



## 8 Troubleshooting

### 8.1 Introduction & Precautions

This section provides a set of procedures for identifying and correcting problems with the 9205/9305 amplifier. Rather than providing an exhaustive and detailed list of troubleshooting specifications, this section aims to provide a set of shortcuts intended to get an inoperative amplifier back in service as quickly as possible.

The procedures outlined in this section are directed toward an experienced electronic technician; it assumes that the technician has knowledge of typical electronic repair and test procedures.

### 8.2 No Signal

Missing output signal on one or more channels may be caused by one of the following:

1. The Control Configuration DIP switch (#5) is set to the Follower (LEFT) position. The default setting for this switch is Master (RIGHT) and this setting should only be changed at the AE Techron. Return the switch setting to Master (RIGHT) to restore the signal path.
2. A signal source is not connected to the BNC input connector for that channel. See the **Amplifier Setup** section in this manual for more information on how to correctly connect each channel to a signal source.

### 8.3 No LEDs Illuminated

If none of the LEDs on the Display Panel are illuminated, check the following:

1. The AC mains are not connected or not on (see the **Amplifier Setup** section for more information).

### 8.4 Run/Standby LED Remains Amber

When the Run/Standby LED is lit solid amber, the amplifier is in Standby mode. Press the front-panel Standby-Run switch to the Run position to place the amplifier in Run mode.

If the amplifier does not return to run mode, check to see if the High/Low Line, Overtemp, or Fault LEDs are lit, and then follow the instructions in this section for remedying the fault condition and returning the amplifier to Run mode.

If the remedies given fail to restart the amplifier, the amplifier may require servicing. See the Factory Service Information at the end of this section.

### 8.5 Power Supply LED Lit

The Power Supply light will come on under two conditions:

1. The amplifier is trying to absorb too much power.
2. Too much power is being demanded from the amplifier

#### 8.5.1 Sinking Too Much Power

This will usually happen when too much power is being returned to the amplifier from the load(s) due to the load reactance being too high for the signal being driven. When this happens, the Power Supply light will typically be the only fault indicator lit.

To clear the fault condition, first turn the amplifier's front Standby-Run switch to the Standby position, and then either adjust the input signal or the load to lower the power being returned to the amplifier. Turn the Standby-Run switch to the Run position to resume amplifier operation.

Note that if more than one channel is being used, you may need to adjust more than one channel in order to optimize the operation of the amplifier.

If the amplifier does not reset, the amplifier may require servicing. Please see the **Factory Service** information at the end of this section.

#### 8.5.2 Excessive Power Requirements

This can happen when the power being demanded from the amplifier exceeds the capability of the power supply to support it. When this happens, both the Power Supply LED and the Overload LED will be lit.

To clear the fault condition, first turn the amplifier's front Standby-Run switch to the Standby position, then reduce the input signal or increase the load impedance on one or more channels to lower the current requirements. Turn the Standby-Run switch to the Run position to resume amplifier operation.

Note that if more than one channel is being used, you may need to make adjustments to more than one channel in order to optimize the operation of the amplifier.

If the amplifier does not reset, the amplifier may require servicing. Please see the **Factory Service** information at the end of this section.

## 8.6 Amplifier Overheats (Over Temp Fault Condition)

There are two possible reasons why the 9205/9305 amplifier is overheating: Excessive power requirements or inadequate airflow.

### 8.6.1 Excessive Power Requirements

An amplifier will overheat if the required power exceeds the amplifier's capabilities. High duty cycles and low-impedance loads are especially prone to cause overheating. To see if excess power requirements are causing overheating, check the following:

1. The application's power requirements fall within the specifications of the amplifier. See the amplifier's Datasheet to verify operating parameters.
2. Faulty output connections and load.
3. Undesired DC offset at the Output and Input signal.

If the amplifier chronically overheats with suitable power/load conditions, then the amplifier may not be receiving adequate airflow. To check for adequate airflow, proceed with the following steps:

### 8.6.2 Check for Inadequate Airflow

1. Check air filters. Over time they can become dirty and worn out. It is a good idea to clean the air filters periodically with a mild detergent and water.

2. Visually inspect fans to assure correct operation while amplifier is On (I). Any inoperative, visibly slow, or reverse-spinning fan should be replaced. Please see the Factory Service information at the end of this section.

An OverTemp condition places the amplifier in Standby mode. If the OverTemp pulse is extremely short, as in the case of defective wiring or switches, the OverTemp pulse may be too brief to observe.

### 8.6.3 Resetting After OverTemp

To reset the amplifier after an OverTemp has occurred, make sure fans are running. Remove the input signal from the amplifier and allow the fans to run until the amplifier has cooled sufficiently and the amplifier automatically returns to Run mode.

**NOTE:** Typically, overheating that occurs in the amplifier outputs due to inadequate airflow or very low impedance loads will clear within 5 minutes. Overheating in the amplifier transformers due to excessive power requirements will take from 5 to 15 minutes to clear. Timing the cool-down period for the amplifier may help to determine the cause of the overheating.

If the fault condition does not clear, return the amplifier for Factory Service.

## 8.7 Over Current Condition

The amplifier monitors the current levels produced at the amplifier output. The Overtemp / Over Current indicator will light red and the amplifier will be placed in Standby mode when the current sensors detect operation at the amplifier's peak current level for more than 500 ms. An Over Current condition can occur when the amplifier is operated at high levels into very-low-impedance loads (below 0.25 ohms).

To remove the amplifier from Standby and return it to normal operation after an Over Current fault has occurred, complete the following steps:

1. Turn off the signal source.
2. Set the front-panel Standby-Run switch to the Standby position (left).

3. Turn off the AC mains.
4. Turn AC mains power back on. If the Fault LED doesn't illuminate again, press the Standby-Run switch to place the amplifier in Run mode and turn the signal source on.
5. If the Fault LED is still illuminated and the Fault condition doesn't clear, return the amplifier for Factory Service. See the Factory Service information at the end of this section.

### **8.8 Factory Service**

If the troubleshooting procedures are unsuccessful, the amplifier may need to be returned for Factory Service. All units under warranty will be serviced free of charge (customer is responsible for one-way shipping charges as well as any custom fees, duties, and/or taxes). Please review the Warranty at the beginning of this manual for more information.

All service units must be given Return Authorization by AE Techron, Inc. before being returned. Return Authorizations can be requested on our website or by contacting our Customer Service Department.

Please take extra care when packaging your amplifier for repair. It should be returned in its original packaging or a suitable alternative. Replacement packaging materials can be purchased for a nominal fee.

Please send all service units to the following address and be sure to include your Return Authorization Number on the box.

**AE Techron, Inc.  
Attn: Service Department / RMA#  
2507 Warren Street  
Elkhart, IN 46516**