

**AE TECHRON®**

---

**Technical Manual**



***DV1.0***  
***Power Supply Amplifier***

***AE TECHRON®***

---

***DV1.0***  
***Power Supply Amplifier***

***Technical Manual***

© ***AE TECHRON*** 2006

2507 Warren St. Elkhart IN 46516 U.S.A.

Phone: (574) 295-9495

Fax: (574) 295-9496

E-Mail: [Sales@aetechron.com](mailto:Sales@aetechron.com)

[www.aetechron.com](http://www.aetechron.com)

# **AE TECHRON®**

## **Limited One-Year Warranty**

### **SUMMARY OF WARRANTY**

**AE TECHRON**, of Elkhart, Indiana (Warrantor) warrants to you, the ORIGINAL COMMERCIAL PURCHASER ONLY of each NEW **AE TECHRON** product, for a period of one (1) year from the date of purchase, by the original purchaser (warranty period) that the product is free of defects in materials or workmanship and will meet or exceed all advertised specifications for such a product. This warranty does not extend to any subsequent purchaser or user, and automatically terminates upon your sale or other disposition of our product.

### **ITEMS EXCLUDED FROM WARRANTY**

We are not responsible for product failure caused by misuse, accident or neglect. This warranty does not extend to any product on which the serial number has been defaced, altered, or removed. It does not cover damage to loads or any other products or accessories resulting from **AE TECHRON** product failure. It does not cover defects or damage caused by the use of unauthorized modifications, accessories, parts, or service.

### **WHAT WE WILL DO**

We will remedy, at our sole discretion, any defect in materials or workmanship by repair, replacement, or refund. If a refund is elected, you must make the defective or malfunctioning component available to us free and clear of all liens or other encumbrances. The refund will be equal to the actual purchase price, not including interest, insurance, closing costs, and other finance charges less a reasonable depreciation on the product from the date of original purchase. Warranty work can only be performed at our authorized service centers or at our factory. Expenses in remedying the defect will be borne by **AE TECHRON**, including one-way surface freight shipping costs within the United States. (Purchaser must bear the expense of shipping the product between any foreign country and the port of entry in the United States and all taxes, duties, and other customs fees for such foreign shipments.)

### **HOW TO OBTAIN WARRANTY SERVICE**

When you notify us of your need for warranty service, we will give you an authorization to return the product for service. All components must be shipped in a factory pack or equivalent which, if needed, may be obtained from us for a nominal charge. Corrective actions will be taken within a reasonable time of the date of receipt of the defective product by us. If the repairs made by us are not satisfactory, notify us immediately.

### **DISCLAIMER OF CONSEQUENTIAL AND INCIDENTAL DAMAGES**

You are not entitled to recover from us any consequential or incidental damages resulting from any defect in our product. This includes any damage to another product or products resulting from such a defect.

### **WARRANTY ALTERATIONS**

No person has the authority to enlarge, amend, or modify this warranty. The warranty is not extended by the length of time for which you are deprived of the use of this product. Repairs and replacement parts provided under the terms of this warranty shall carry only the unexpired portion of this warranty.

### **DESIGN CHANGES**

We reserve the right to change the design of any product from time to time without notice and with no obligation to make corresponding changes in products previously manufactured.

### **LEGAL REMEDIES OF PURCHASER**

There is no warranty which extends beyond the terms hereof. This written warranty is given in lieu of any oral or implied warranties not contained herein. We disclaim all implied warranties, including, without limitation, any warranties of merchantability or fitness for a particular purpose. No action to enforce this Warranty shall be commenced later than ninety (90) days after expiration of the warranty period.

**AE TECHRON** Customer Service Department  
2507 Warren St. Elkhart IN 46516-0000 U.S.A.  
(574) 295-9495

---

# 1

## ***Pre- Installation***

This section describes safety conventions used within this document and provides essential information about the **Model DV 1.0** amplifier. Review this material before installing or operating the amplifier.

**AE TECHRON** is committed to continuous product improvement. Technical progress may result in minor variations between this manual and a particular unit. Any significant changes or customizations will be reflected in revisions of this manual. Customers are encouraged to promptly add any additional information about their particular unit to this manual.



---

## 1.1 Safety Conventions

The DV 1.0 amplifier is a highly sophisticated instrument. Accordingly, this document provides full information on the amplifier including service procedures. Safety should be your primary concern as you use this product and follow these procedures.

Special hazard alert instructions appear throughout this manual. Note the following examples:



 <b>DANGER</b>
DANGER represents the most severe hazard alert. Extreme bodily harm or death will occur if these guidelines are not followed. Note the explanation of the hazard and instructions for avoiding it.



 <b>WARNING</b>
WARNING alerts you to hazards which could result in severe injury or death. Note the explanation of the hazard and the instructions for avoiding it.



 <b>CAUTION</b>
CAUTION indicates hazards which could result in potential personal injury or equipment or property damage. Once again, note the explanation of the hazard and the instructions for avoiding it.

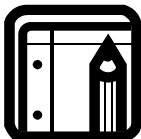

**NOTE:** A Note represents information, which needs special emphasis but does not represent a hazard.

---

## 1.2 Features



The **AE TECHRON DV 1.0** is a 2-channel amplifier which offers the customer a number of useful features:

- Switching Power Supply for reduced weight.
- High power-density, with all two-channel models in a 2U chassis.
- Input sensitivity is independently selectable for each channel. Choose low-impedance, or 26 dB.
- *PIP2*<sup>™</sup> (Programmable Input Processor) connector accepts accessory modules that tailor the amplifier to suit specific applications.
- Removable terminal block input connectors, with “Y” Input Switch in the standard PIP2-BBY module.
- Comprehensive array of indicators, including: Power, Data, and Bridge; along with Ready, Signal, Clip, Thermal and Fault for each channel, provide accurate diagnostics.
- Blue Power Indicator flashes if the amplifier shuts off due to an under/over-voltage condition on the AC mains.
- Advanced protection circuitry guards against: shorted outputs, DC, mismatched loads, general overheating, under/overvoltage, high-frequency overloads, and internal faults.
- The AE Techron DV1.0 uses class I (BCA®) output topologies which offer the best in amplifier reliability.
- Class I is the lowest distortion, lowest noise, and highest performing topology available among switch-mode amplifiers.
- Continuously-variable fans optimize cooling efficiency.

All **AE TECHRON** amplifiers are tested at the factory to assure operation at full efficiency upon delivery. Custom configurations are available, as well as full system implementations.

---

## 1.3 Specifications

Specifications are for units in Dual mode driving both channels into 8-ohm loads, (26 dB = 20 times voltage gain) and operating from 120 VAC, unless otherwise specified.

“Standard 1 kHz Power” refers to maximum average power in watts at 1 kHz with 0.1% THD.

“Full Bandwidth Power” refers to maximum average power in watts from 20 Hz to 20 kHz with 0.1% THD.

### 1.3.1 Performance

**Frequency Response:**  $\pm 0.25$  dB from 20 Hz to 20 kHz at 1 watt.

**Signal to Noise Ratio:** < 105 dB (ref. rated power, 20 Hz to 20 kHz, A-weighted).

**Total Harmonic Distortion (THD):** <0.35% at full rated power, from 20 Hz to 20 kHz.

**I. M. Distortion:** <0.35% at 60 Hz and 7 kHz at 4:1, from -40 dB to full rated power.

**Damping Factor:** > 3000 at 10 Hz to 100 Hz.

**Crosstalk:** >80 dB (below rated power) 20 Hz to 1 kHz.

**Common Mode Rejection (CMR)** (20Hz to 1kHz, typical): 50 dB

**DC Output Offset:** < 2 mV

**Input Impedance** (nominally balanced, nominally unbalanced): 10 k ohms, 5 k ohms.

**Maximum Input Level:**

Before input compression: + 20 dBu

Absolute maximum: +32 dBu

**Load Impedance (Note: Safe with all types of loads):**

Dual: 2, 4, 8, 16 Ohm

Bridge Mono: 4, 8, 16 Ohm

**Voltage Gain (at maximum level setting):**

26 dB: 20:1 (26 dB)

8/4 Ohm Operation: 63.9:1 (36 dB)

**Input Sensitivity:**

2/4/8 ohms: 1.4V

26 dB gain: 4 ohm load: 3.17V

8 ohm load: 4.48 V

**Required AC Mains (+15%, -25%):** 120V/60Hz, 230V/50Hz.

**Power Draw at Idle** (120 VAC mains): 35W (Standby Mode).

**Overall Group Delay:** < 120 usec.

---

### 1.3.1 Performance (continued)

**Cooling:** Continuously variable speed forced air, front-to-back airflow.

**Dimensions:** Width - 19 inches (48.3 cm)  
Height - 3.5 inches (8.9 cm)  
Depth - 14.25 inches (36.2 cm)

**Net Weight:** 27.0 lbs. (12.3 kgs)

**Shipping Weight:** 32.0 lbs. (14.5 kgs)

---

### 1.3.2 Power

**Output Power:** The following are typical for standard 1 kHz power from units configured for 120 VAC, 60 Hz power.

**Single Channel:**

Ohms	40 mSec			1 Hour		
	Volts	Amps	Watts	Volts	Amps	Watts
No Load	115			115		
16	101	6	631	98	6	594
8	90	11	1013	70	9	604
4	73	18	1332	48	12	564
2	50	25	1250	33	16	528
1	31	31	930	N/R*	N/R*	N/R*

\*N/R = Not Recommended

**Bridge Mono:**

Ohms	40 mSec			1 Hour		
	Volts	Amps	Watts	Volts	Amps	Watts
No Load	230			230		
16	180	11	2025	139	9	1208
8	146	18	2665	95	12	1128
4	100	25	2500	65	16	1056
2	61	31	1861	N/R*	N/R*	N/R*

\*N/R = Not Recommended

---

### 1.3.2 Power (continued)

Both Channels:

Ohms	40m Sec			5 Minute			Continuous		
	Volts	Amps	Watts	Volts	Amps	Watts	Volts	Amps	Watts
16.5	100.5	6.09	612.13	11.5	6.1	612.1	97.5	5.9	576.1
8	90	11.25	1012.5	71.5	8.9	639.0	69.5	8.7	603.8
4	73	18.25	1332.25	50	12.5	625.0	47.5	11.9	564.1
2	50	25	1250	35	17.5	612.50	32.5	16.3	528.1
1	30.5	30.5	930.25	21.5	21.5	462.3	N/R*	N/R*	N/R*

\*N/R = Not Recommended

---

### 1.3.3 Performance Graphs

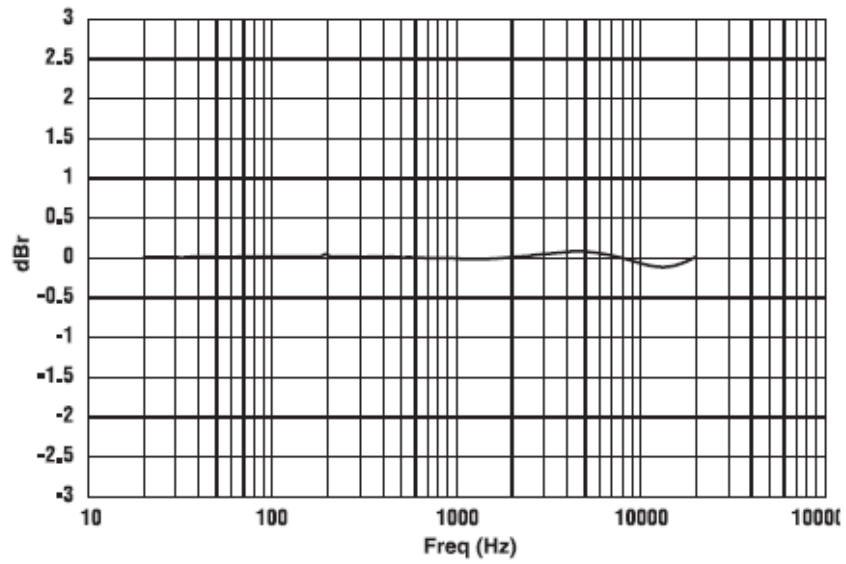

*DVI.0 Typical Frequency Response*

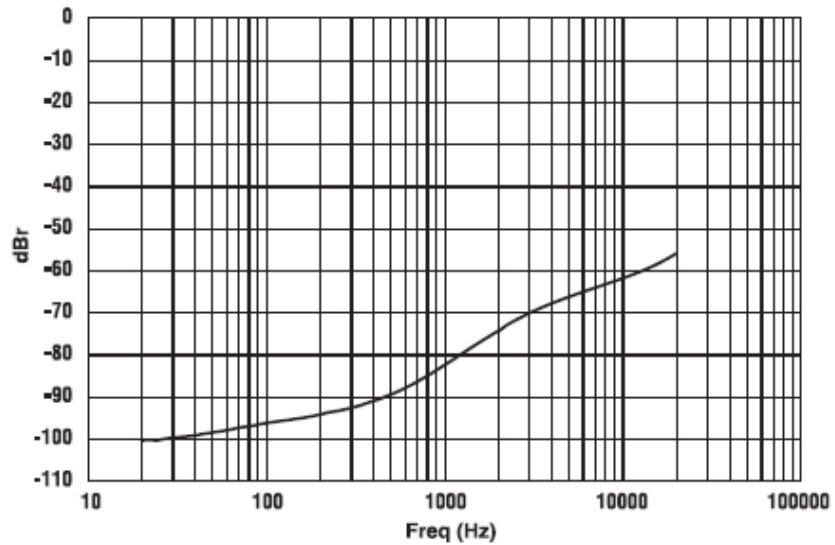

*DVI.0 Typical Crosstalk vs. Frequency*

---

### 1.3.3 Performance Graphs (continued)

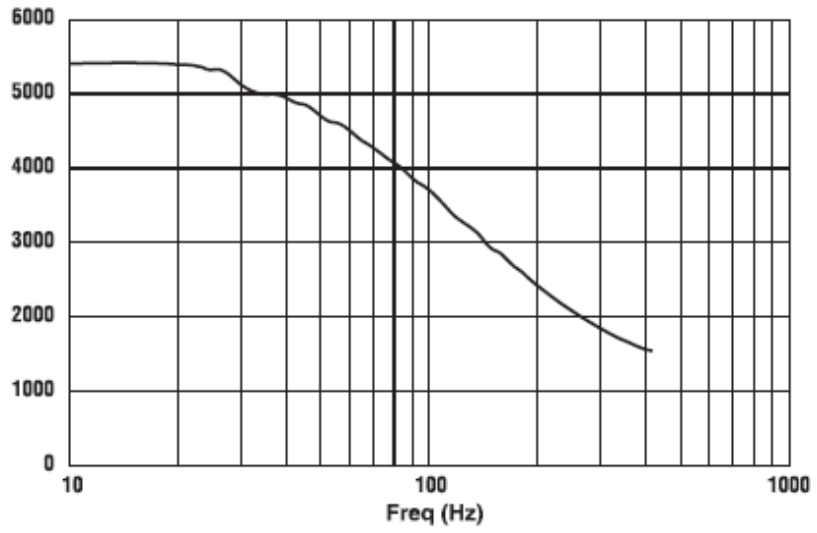

*Typical Dampening Factor vs. Frequency*

### 1.3.4 Power Draw and Thermal Dissipation

Given:

- Pink noise 12dB crest factor, bandwidth limited 22Hz to 22kHz.
- Typical line impedance used.
- Measurements made with 120VAC mains. Data based on all channels driven.
- Line current figures for 230VAC units derived by multiplying 120VAC figures by 0.5.
- Line current figures for 100VAC units (not shown) are 1.2 times the line current figures of 120VAC units.
- Power draw (“watts in”) of 100VAC units is the same as power draw of 120VAC units.

	Load	Rated Power	Line Current 120VAC	Line Current 230VAC	Watts			Thermal Dissipation	
					watts in	watts out	dissipated	Btu/hr	kcal/hr
At Idle (sleep mode)					40	0	40	137	34
1/8th Power Pink Noise Typical of program material just at clip.	8 Ohms/Ch. 16 Ohms Bridge	1000x2 2000	6.6	3.3	546	256	290	988	249
	4 Ohms/Ch. 8 Ohms Bridge	1000x2 2000	7.0	3.5	563	255	307	1049	264
	2 Ohms/Ch. 4 Ohms Bridge	1000x2 2000	7.2	3.6	602	251	351	1198	302
	70/100V/Ch. 140/200V Bridge	1000x2 2000	6.7	3.4	639	257	382	1304	329
1/3rd Power Pink Noise Typical of program material with severe clipping.	8 Ohms/Ch. 16 Ohms Bridge	1000x2 2000	11.3	5.6	980	676	304	1036	261
	4 Ohms/Ch. 8 Ohms Bridge	1000x2 2000	12.3	6.2	1064	672	392	1338	337
	2 Ohms/Ch. 4 Ohms Bridge	1000x2 2000	13.7	6.9	1190	705	485	1655	417
	70/100V/Ch. 140/200V Bridge	1000x2 2000	11.6	5.8	990	674	316	1080	272

## **Installation**

This section describes general guidelines for installing the **Model DV1.0** amplifier with special emphasis on system installations.

### **2.1 Unpacking**

Every **AE TECHRON Model DV1.0** is carefully inspected and tested prior to leaving the factory. Carefully unpack and inspect the unit for damage in shipment. Besides the amplifier, you should find this manual and mounting hardware in the package.

- 1) Inspect the crating for **ANY** signs of damage.
  - a.) Make written notes of any damage for future reference.
  - b.) If damage is found notify the transportation company immediately.
  - c.) Save the shipping carton and packing materials as evidence of damage for the shipper's inspection.
  - d.) If severe damage is apparent, **DO NOT** proceed until a representative of the shipping company is present.
- 2) Uncrate/unpack the amplifier
- 3) Save the packing materials for later use in transporting **or** shipping the unit.

**AE TECHRON** will cooperate fully in the case of any shipping damage investigation. In any event, replacement-packing materials are available from **AE TECHRON**.

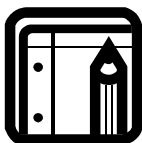

**NOTE: Never ship this unit without proper packaging.**

---

## 2.2 Mounting

The DV1.0 is designed for standard 19-inch (48.3 cm) rack mounting and "stack" mounting without a cabinet. For optimum cooling and rack support, multiple units should be stacked directly on top of each other.



### WARNING

To reduce the risk of *ELECTRIC SHOCK* or *FIRE HAZARD*, DO NOT expose the DV1.0 to rain or moisture.



### CAUTION

Always support the back of the unit. Provide extra support if the unit will be transported.



### CAUTION

Before you begin, make sure your amplifier is disconnected from the power source, with power switch in the "off" position and all level controls turned completely down (counterclockwise).

---

## 2.3 Cooling

When using an equipment rack, mount units directly on top of each other. Close any open spaces in rack with blank panels. **DO NOT** block front or rear air vents. The side walls of the rack should be a minimum of two inches (5.1 cm) away from the amplifier sides, and the back of the rack should be a minimum of four inches (10.2 cm) from the amplifier back panel.

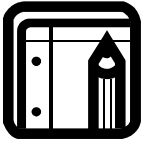

**NOTE: Refer to Section 1.3.4 for detailed information on thermal dissipation.**

When mounting the amplifier in a rack cabinet, the back wall of the rack should be at least 3 inches (7.6 cm) away from the back of the amplifier chassis as shown below.

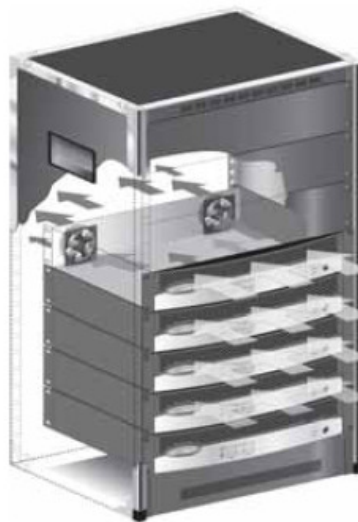

*Airflow*

---

## 2.4 Choose Input Wire and Connectors

Figure 2.1 shows connector pin assignments for balanced wiring, and Figure 2.2 shows connector pin assignments for unbalanced wiring.

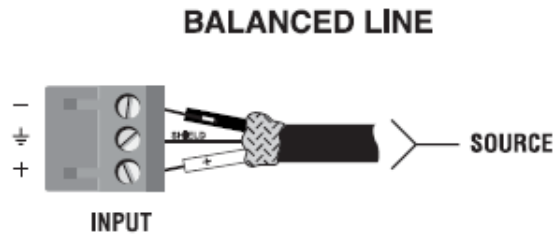

*Figure 2.1 Balanced Input Connector Wiring*

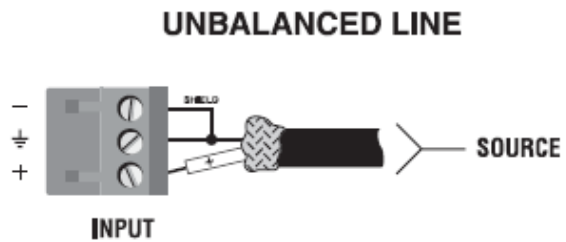

*Figure 2.2 Unbalanced Input Connector Wiring*

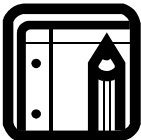

**NOTE:** Custom wiring should only be performed by qualified personnel.

---

## 2.5 Choose Output Wire and Connectors

A protective cover is installed over the barrierstrip output. Some models have a cover with two holes. To remove this type of cover:

1. Loosen screws inside top and bottom holes of cover (see Figure 2.4).
2. Slide cover to left or right, then pull it off away from the amplifier.

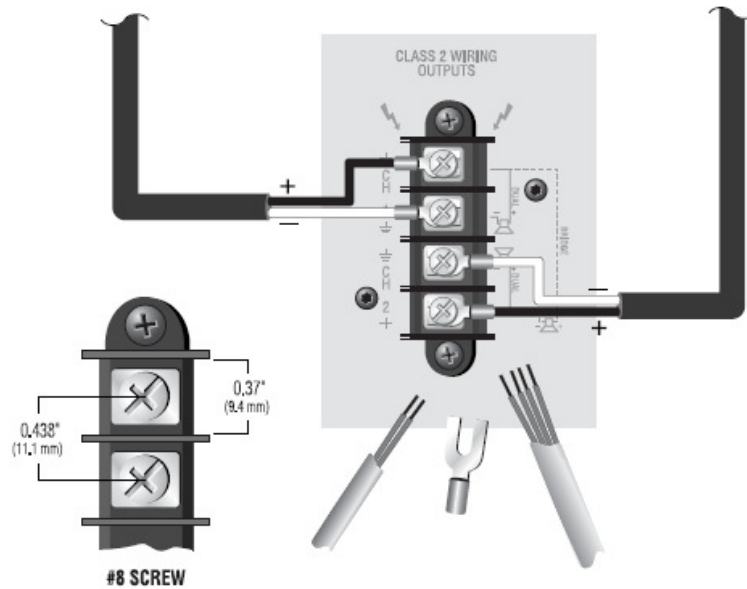

Figure 2.3 Typical Output Connector Wiring

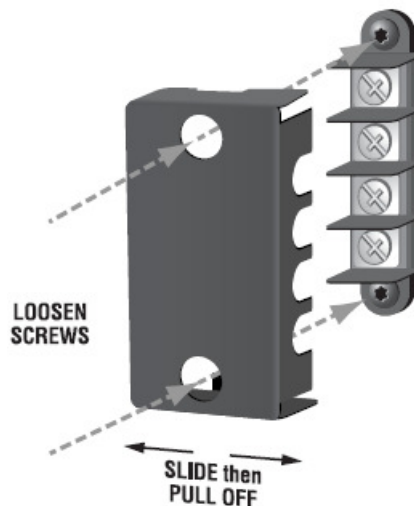

Figure 2.4 How to Remove the Two-Holed Barrier Block Cover

---

## 2.5 Choose Output Wire and Connectors (continued)

**AE TECHRON** recommends using professionally constructed, high-quality, two- or four-conductor, heavy gauge wire and connectors. You may use terminal forks up to 10 AWG or bare wire for your output connectors (see Figure 2.3). To prevent the possibility of short-circuits, wrap or otherwise insulate exposed cable connectors. For best results, **AE TECHRON** recommends Panduit part #PV10-10LF-L or equivalent terminal fork. Screw spacing is also shown in Figure 2.3.

Using the guidelines below, select the appropriate size of wire based on the distance from amplifier to load (low-impedance loads only).

<u>Distance</u>	<u>Wire Size</u>
up to 25 ft (7.6m)	16 AWG
26-40 ft (7.9-12.2m)	14 AWG
41-60 ft (12.5-18.3m)	12 AWG
> 60 ft (18.3m)	10 AWG

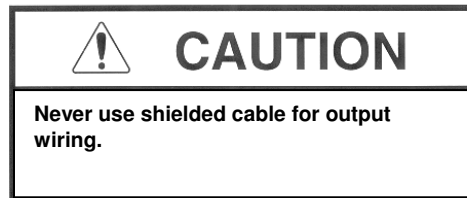

---

## 2.6 Wiring Your System

### 2.6.1 Dual (2-8 Ohm) Mode

Typical input and output wiring, along with Attenuator and Mode Switch settings are shown in Figures 2.5 and 2.6. Make sure the Mode switch is set to the “Dual” position when operating in Dual mode.

**INPUTS:** Connect input wiring for each channel. The Y switch on the rear PIP panel can be used to parallel the channel inputs when only mono input signals are necessary. The amplifier’s channel outputs are still independent.

**OUTPUTS:** Maintain proper polarity (+/-) on output connectors. Connect the Channel 1 speaker’s positive (+) lead to amplifier Channel 1 positive terminal; repeat for negative (-). Repeat Channel-2 wiring as for Channel 1. Refer to Section 2.5 for output connector pin assignments.

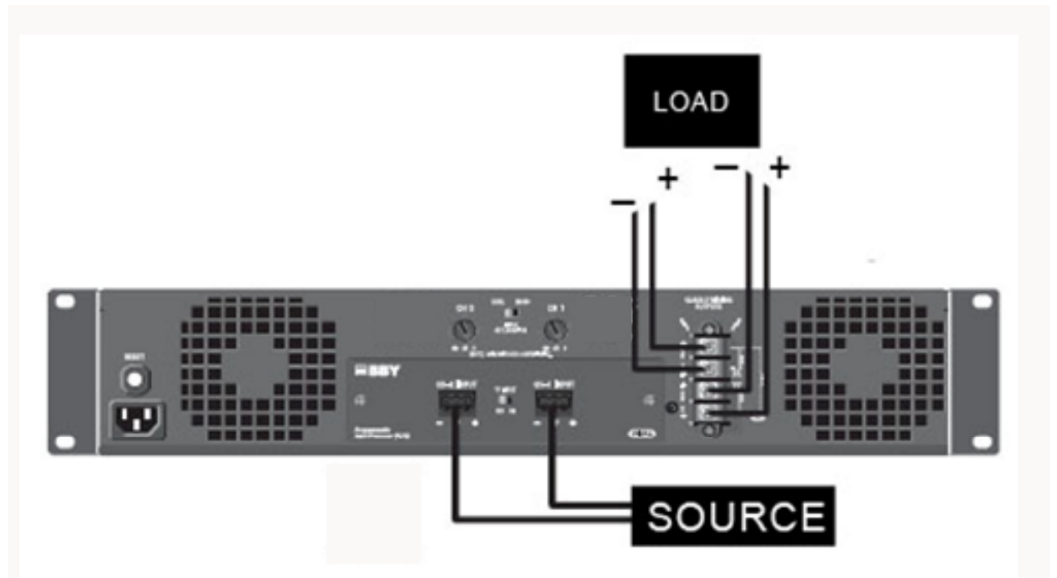
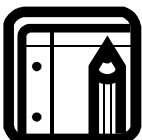

Figure 2.5 System Wiring, Dual Mode (Above) and Attenuator and Mode-Switch Settings for Dual Mode (Below)



Figure 2.6



**NOTE:** Always route the input and output wires in separate bundles.

---

## 2.6.2 Bridge-Mono (4-16 Ohm) Mode

Typical input and output wiring, along with Attenuator and Mode Switch settings, are shown in Figures 2.6 and 2.7. Make sure the Mode switch is set to the “Mono” position when operating in Bridge-Mono mode.

**INPUTS:** Connect input wiring to Channel 1 only.

**OUTPUTS:** Connect the speaker across the positive terminals of each channel pair. Do not use the negative terminals of the channel pair when the pair is being operated in Bridge-Mono mode. Refer to Section 2.5 for output connector pin assignments.

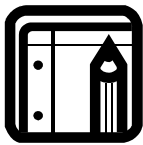

**NOTE:** When operating in Bridge-Mono mode, turn down (full CCW) the Input Attenuator for Channel 2. The Channel-1 Input Attenuator works both channels.

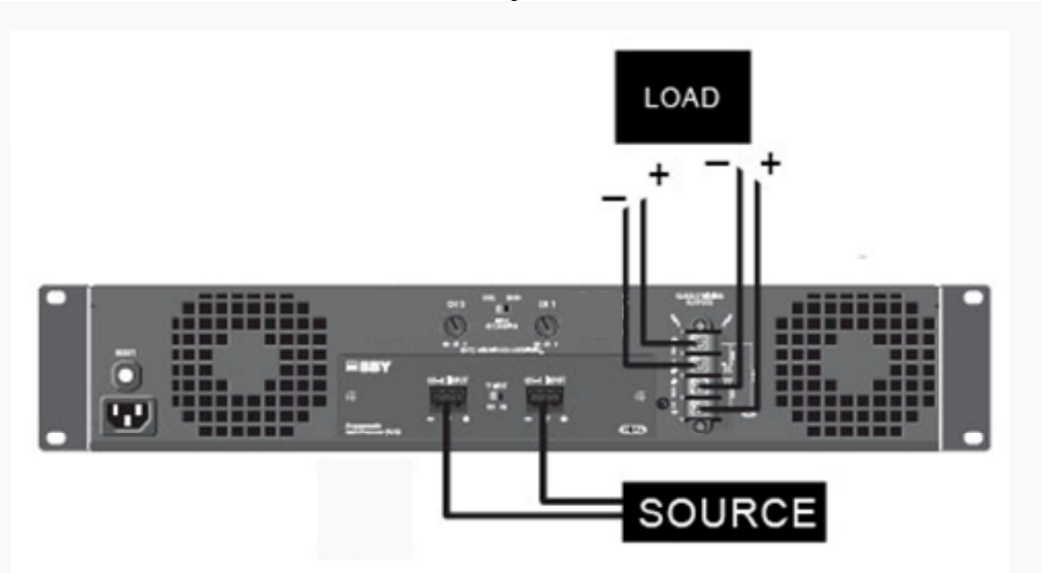

Figure 2.6 System Wiring, Bridge-Mono Mode (Above) and Attenuator and Mode Switch Settings for Bridge-Mono Mode (Below).

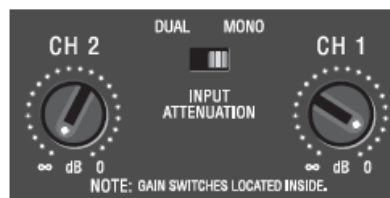
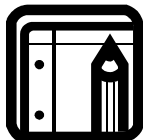

Figure 2.7



**NOTE:** Always route the input and output wires in separate bundles.

---

### 2.6.3 Dual Mode with “Y” Input

This configuration feeds a mono signal to both Channel 1 and Channel 2.

**INPUTS:** Connect the signal to the Channel 1 input. On the back panel, set the “Y” Input Switch to ON.

**OUTPUTS:** Connect the Channel 1 load’s positive (+) lead to Channel 1 positive terminal of amplifier; repeat for negative (-). Connect the Channel 2 load’s positive (+) lead to Channel 2 positive terminal of amplifier; repeat for negative (-).

See Figure 2.8. Turn up both Input Attenuators and set the Mode Switch to Dual.

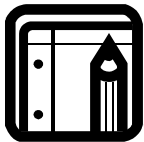

**NOTE:** When the “Y” Input Switch is on, the Channel 2 input can be used to daisy-chain to another amplifier.

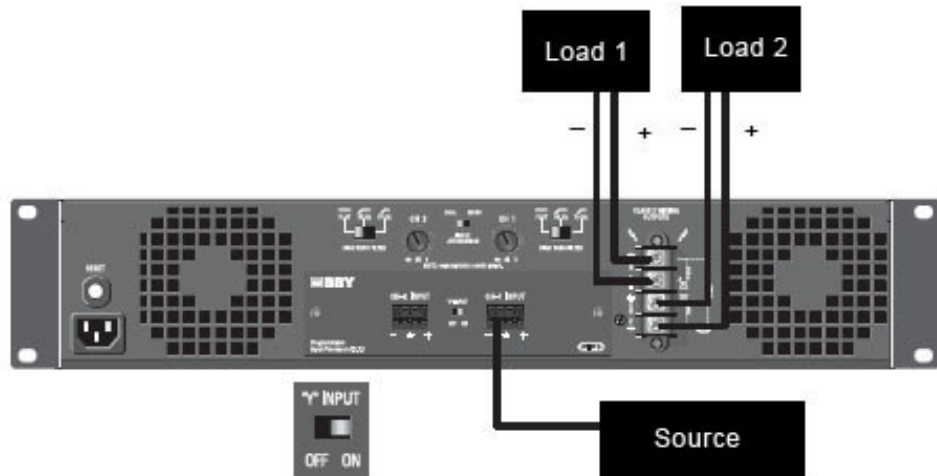

*System Wiring for “Y” Input Mode (Above) and Attenuator and Mode-Switch Settings for “Y” Input Mode (Below).*

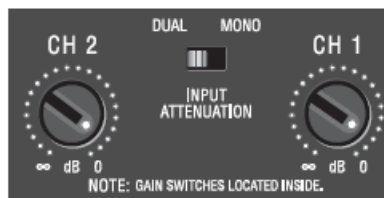
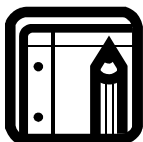

Figure 2.8



**NOTE:** Always route the input and output wires in separate bundles.

---

## 2.7 Connect to AC Mains

On the back panel, check whether your amplifier is labeled for 120V or 220-240V AC mains. Connect your amplifier to the corresponding AC mains power source (power outlet) with the supplied AC power cord set.

First connect the IEC end of the cordset to the IEC connector on the amplifier. Then, with the amplifier in the OFF position, plug the other end of the cordset into the AC mains.



Amplifiers don't create energy. The AC mains voltage and current must be sufficient to deliver the power you expect. Check the amplifier's back-panel label which specifies the required AC mains voltage and frequency. The AC mains voltage must be no more than 15% above the required voltage, and no less than 25% below the required voltage. The AC mains frequency must be within the required frequency range. If you are unsure of the output voltage of your AC mains, please consult your electrician.

## 2.8 Start-up Procedure

Use the following procedure when first turning on your amplifier:

1. Turn down the level of your audio source.
2. Turn down the level controls of the amplifier.
3. Turn on the "Power" switch. The Power indicator should glow. Wait for the "Ready" LED to illuminate.
4. Turn up the level of your signal source to an optimum level.
5. Turn up the level controls on the amplifier until the desired loudness or power level is achieved. Verify that the Signal LED is flashing.
6. Turn down the level of your signal source to its normal range.

If you ever need to make any wiring or installation changes, don't forget to turn off the amplifier and disconnect the power cord.

## Operation

This section describes general guidelines for operating the **Model DV1.0** amplifier.

### 3.1 Precautions

Your amplifier is protected from internal and external faults, but you should still take the following precautions for optimum performance and safety:

1. Before use, your amplifier first must be configured for proper operation, including input and output wiring hookup. Improper wiring can result in serious operating difficulties. For information on wiring and configuration, please consult section 2, **Installation**.
2. Use care when making connections, selecting signal sources and controlling the output level.
3. Do not short the ground lead of an output cable to the input signal ground. This may form a ground loop and cause oscillations.
4. **Never connect the output to a power supply, battery or power main. Electrical shock may result.**
5. Tampering with the circuitry or making unauthorized circuit changes may be hazardous and invalidates all agency listings.
6. Do not operate the amplifier with the red Clip LEDs constantly flashing.
7. Do not operate the amplifier with less than the rated load impedance. Due to the amplifier's output protection, such a configuration may result in premature clipping.

---

## 3.2 Front Panel Controls and Indicators

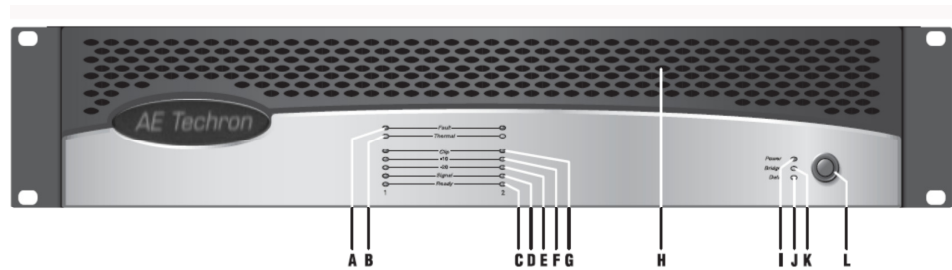

### A. Fault Indicator

Red LED, one per channel, flashes when the amplifier output channel has stopped operating. Usually this means that the amplifier must be serviced.

### B. Thermal Indicator

Red LED, one per channel, illuminates when the channel has shut down, or is very near shutting down, due to thermal stress or overload.

### C. Ready Indicator

Green LED, one per channel, illuminates when the channel is initialized and ready to produce output. Indicator is off when the channel is set to standby mode via the System Architect or IQ Control Software packages.

### D-G Signal Indicators

Three green LEDs per channel indicate the amplifier's input and output signal levels. From bottom to top the LEDs are:

**D. Signal:** input signal is above  $-40$  dBu.

**E.  $-20$  dB:** amplifier output is within 20 dB of clipping.

**F.  $-10$  dB:** amplifier output is within 10 dB of clipping.

### G. Clip Indicator

Red LED, one per channel, illuminates when the channel's output signal reaches the onset of audible clipping. The Clip Indicator also will illuminate during Thermal Level Control (TLC) limiting or when the input compressor/limiter is protecting the amplifier from input overload.

### H. Cooling Vents

Front-to-rear forced airflow.

### I. Power Indicator

Blue LED indicates AC power has been applied and is within the safe operating range of the power supply. The LED will flash when the AC line voltage is approximately 15% above or 25% below the nominal rated value.

---

## ***3.2 Front Panel Controls and Indicators (continued)***

### **J. Data Indicator**

Feature not implemented.

### **K. Bridge Mode Indicator**

Yellow LED illuminates when the rear panel Mode Switch is set to the “Bridge” position.

### **L. Power Switch**

Push-on / push-off switch.

---

### 3.3 Back Panel Controls and Connectors

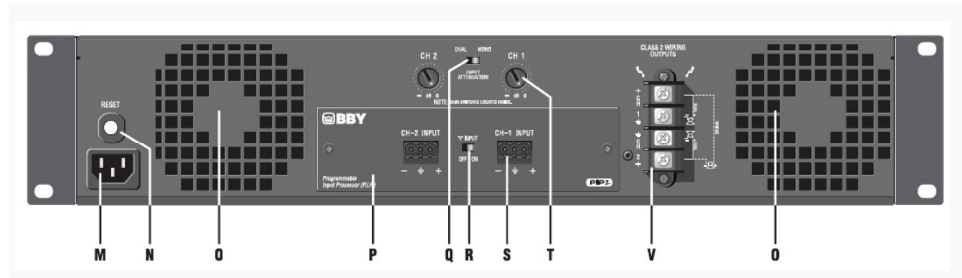

#### M. Power Cord Connector

Standard 15 amp IEC inlet. A circuit breaker located near the IEC power inlet protects the amplifier from excessive AC current draw.

#### N. Reset Switch

Resets the circuit breaker that protects the power supply.

#### O. Ventilation Grille

Air flow is front to back. Do not block the ventilation grilles.

#### P. PIP™ Input Panel

PIP2-BBY module includes two balanced 3-pin removable barrier connectors. The “Y” Input Switch is described under letter R.

#### Sensitivity Switches

Behind the input panel are the Input Sensitivity Switches. One 3-position switch per channel selects various sensitivity settings.

#### Q. Mode Switch

This two-position switch is used to select the amplifier’s mode of operation: Dual or Bridge Mono. Dual mode is used for 2-8 ohm loads. Bridge mode is used for 4-16 ohm loads.

#### R. “Y” Input Switch

When set to ON, this switch parallels the input signals of the two channels, for use when the input signal is mono. The amplifier’s channel outputs are still independent. The “Y” Input Switch also can be used to daisy-chain the signal to another amplifier.

#### S. Input Connectors

Balanced 3-pin terminal block connectors, one per channel.

#### T. Channel Level Controls

One 21-position detented rotary attenuator per channel, ranging from –100 dB to 0 dB gain.

---

### ***3.3 Back Panel Controls and Connectors (continued)***

#### **V. Speaker Connectors**

One four-pole touch-proof terminal strip. Accepts up to 10 AWG terminal forks.

#### **Output Cover (not shown)**

This covers the output connectors, protecting users from the connectors' potentially high voltage. This cover is required for Class 2 wiring installations.

---

# 4

## ***Advanced Features and Options***

This section describes protections and diagnostic features of the **Model DV1.0** amplifier.

### ***4.1 Protection Systems***

Your **AE Techron** amplifier provides extensive protection and diagnostic capabilities, including, fault indicators, DC protect, AC under/over voltage protection, inrush limiting, and variable speed fans.

#### ***4.1.1 Fault***

The amplifier will light the Fault LED if the amplifier output stage stops operating. If this happens, contact **AE TECHRON** for servicing information.

#### ***4.1.2 Low-Pass Filters***

Gaussian-approximation ultrasonic filters prevent ultrasonic feedback and HF burnout of transducers. This type of filter preserves transient response better than a Butterworth filter.

#### ***4.1.3 AC Under/Over Voltage Protection***

If the AC line voltage drops below 25% or rises above 15% of the nominal operating voltage of the amplifier, the amplifier's power supply turns off and the blue Power LED flashes. The amplifier will turn back on when the AC line voltage returns to safe operating levels (within +15% / -25%).

#### ***4.1.4 Circuit Breaker***

A circuit breaker located near the IEC power inlet protects the amplifier from excessive AC current draw.

#### ***4.1.5 Inrush Limiting***

A soft-start circuit in the power supply minimizes the amplifier's current draw during power-on.

#### ***4.1.6 Variable-Speed Fans***

Two continuously variable speed fans direct the airflow through the amplifier for cooling.

---

## 4.2 Advanced Features

### 4.2.1 Switching Power Supply

The switching Power Supply minimizes the amplifier's weight.

Typical non-switching power supplies require large, heavy transformers in order to produce the required power at the output stage. These transformers must be large to operate at 50 to 60 Hz (standard AC supplied by the power company).

By contrast, switching power supplies can operate with a much smaller (and lighter) transformer because they first convert the AC up to a much higher frequency, thereby reducing waste. The power supply is voltage-specific, allowing use in regions using 120V or 240V.

### 4.2.2 Sleep Circuit

Lowers standby power consumption by shutting down the high-voltage supplies during idle periods.

### 4.2.3 Input Sensitivity Switches

To access the Input Sensitivity Switches, turn off the amplifier and remove the PIP2-BBY Input Panel. The switches are in the top surface of the cavity behind the Input Panel. One 3-position switch per channel selects among these settings:

- 1.4V (Gain of 63.9)
- 26 dB gain (Gain of 20)
- 1.4V (not normally used).

Section 1.3 lists the input sensitivity for the 26 dB gain setting.

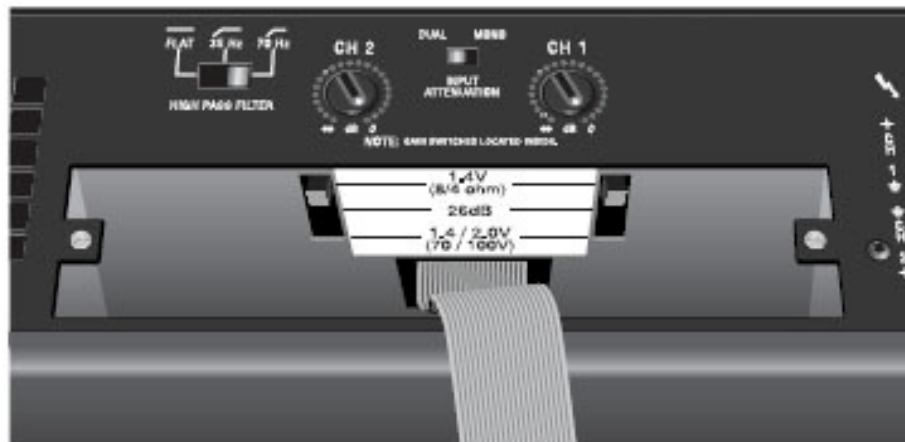

---

## 4.3 Advanced Features and Options

The versatile PIP (Programmable Input Processor) modules provide flexible expansion features that can be added to customize the amplifier. PIP modules plug into the connector inside the back panel of the amplifier. Contact **AE TECHRON** for descriptions of available PIP and PIP2 modules.

### 4.3.1 Nominal Attenuation Settings

The signal level for each input can be attenuated accurately by adjusting the 21-step Level Control (see Section 4.2). Figure 4.1 shows the attenuation in dB for each detent. The setting of the input-sensitivity switch varies the actual attenuation as shown. The accuracy of the attenuation varies with the setting: see Tolerance (dB).

Detent	26 dB	Tolerance (dB)	4/8 ohm or 70/100V
0 (full CW)	0.0	±1	0.0
1	0.5	±1	0.5
2	1.0	±1	1.5
3	2.0	±1	3.5
4	3.0	±1	5.0
5	4.0	±1	6.5
6	5.0	±1	8.0
7	6.0	±1	9.5
8	7.0	±1.5	11.0
9	8.0	±1.5	13.0
10	9.0	±1.5	14.5
11	10.5	±1.5	16.0
12	12.0	±1.5	18.0
13	13.5	±3	20.0
14	15.0	±3	22.0
15	18.0	±3	24.0
16	21.0	±3	26.0
17	24.0	±3	30.0
18	36.0	±6	42.0
19	48.0	±6	54.0
20 (full CCW)	OFF	OFF	OFF

Figure 4.1  
Attenuation vs. Detent of Level Controls for DV1.0, 2-Channel Amplifiers

## Troubleshooting

This section describes conditions, and possible reasons for common situations encountered during the use of **Model DV1.0** amplifier.

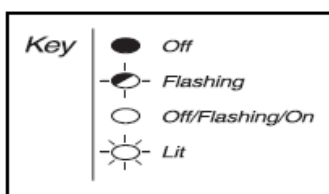

"Off/Flashing/On" above means that the LED can be off, or flashing, or on.

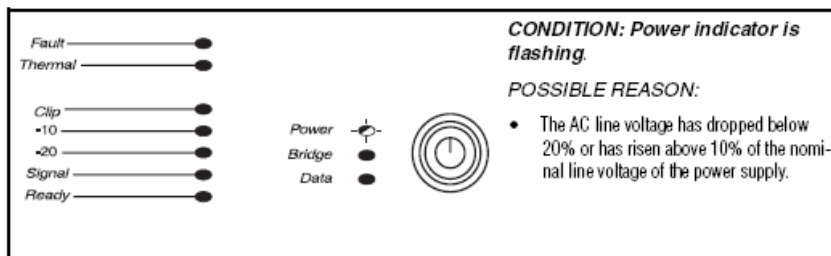
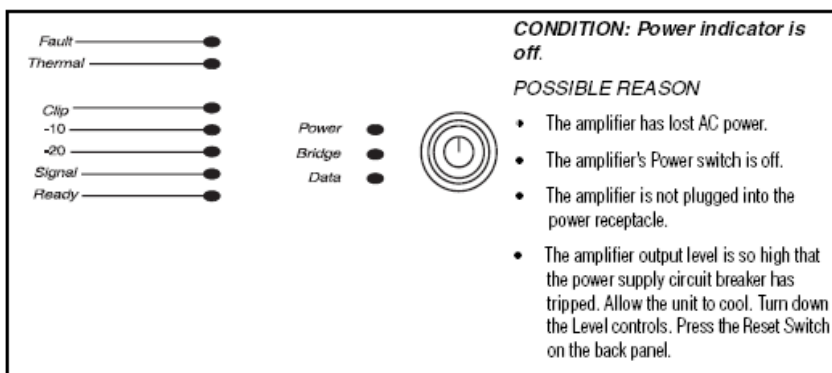

**CONDITION: Thermal indicator is on.**

**POSSIBLE REASON:**

- The amplifier is becoming too hot for safe operation. Allow amplifier to cool. Check for loads less than 2 ohms, and for excessive input levels. Check for proper ventilation and proper mode-switch setting.

**CONDITION: Fault indicator is flashing.**

**POSSIBLE REASON:**

- The amplifier channel has stopped operating. Refer the unit to an authorized Service Center.

**CONDITION: Distorted sound.**

**POSSIBLE REASON:**

- Load is wired incorrectly or /Mono mode switch is set incorrectly. Check both.
- Input is overloaded by a signal level that is too high. Turn down your amplifier level controls, or turn down the input signal, until the clip light goes out.

**CONDITION: No input signal.** Signal indicator is not flashing even though audio is applied, and the channel is ready.

**POSSIBLE REASON:**

- Input signal level is very low.
- Level controls are turned down.

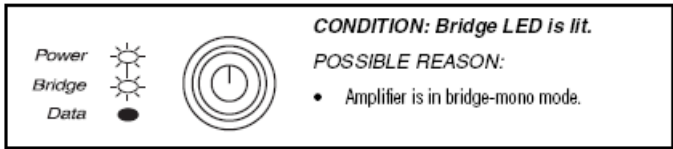
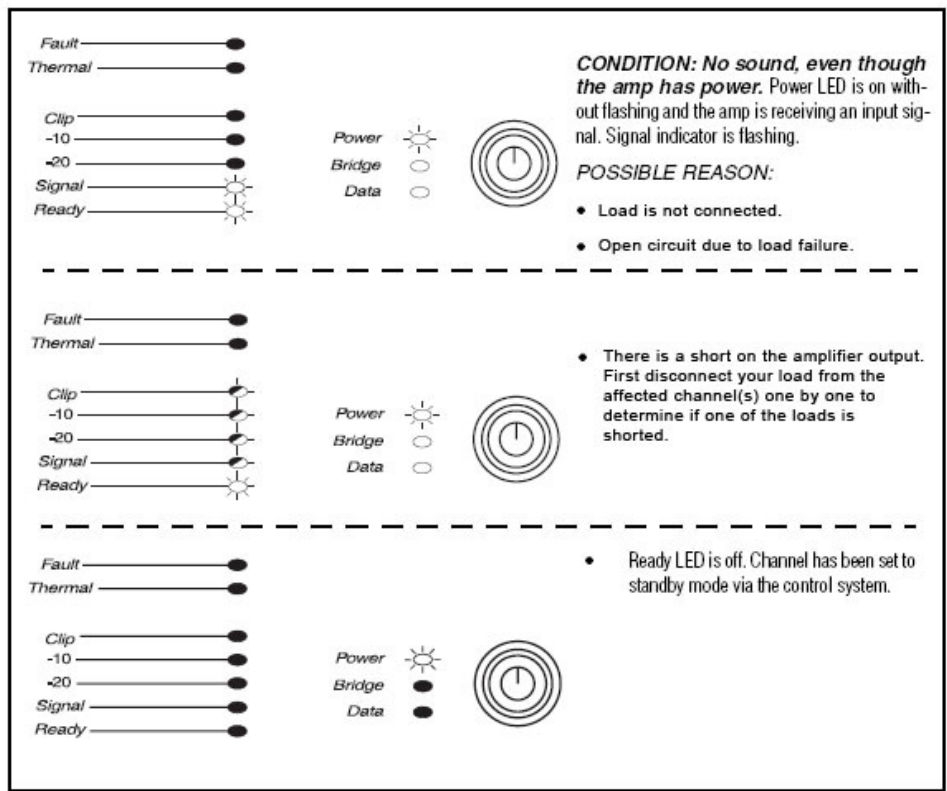

---

## Service Information

This amplifier has sophisticated circuitry, which should only be serviced by a fully trained technician.

### 6.1 Qualified Service

**AE TECHRON** will provide service to the original purchaser of each new **AE TECHRON DV1.0** for a period of one (1) year from the date of purchase if all conditions of the warranty have been met. When you notify us of your need for warranty service, we will give you an authorization to return the product for service.

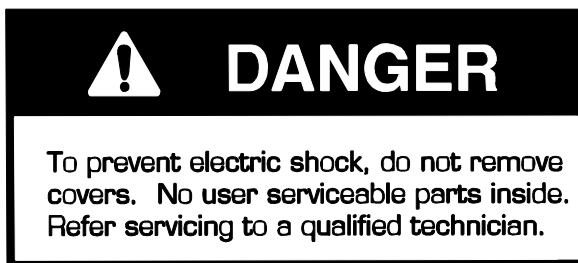

Warranty work can only be performed at our authorized service centers or at our factory. Expenses in remedying the defect will be borne by **AE TECHRON**, including one-way surface freight shipping costs within the United States. (Purchaser must bear the expense of shipping the product between any foreign country and the port of entry in the United States and all taxes, duties, and other customs fees for such foreign shipments.)

#### 6.1.1 Authorized Service Center Service

Service may be obtained from an authorized service center. (Contact **AE TECHRON** for a list of authorized service centers.) To obtain service, simply present the bill of sale as proof of purchase along with the defective unit to an authorized service center. They will handle the necessary paperwork and repair. Remember to transport your unit in the original factory pack.

---

### **6.1.2 Factory Service**

To obtain factory service, write a letter describing as fully as you can the problem and send it along with your proof of purchase and the defective unit. For warranty service, we will pay for ground shipping back to you if you are within the continental United States. After repair and thorough testing the factory will return your serviced unit via truck. Please contact us if other arrangements are required.

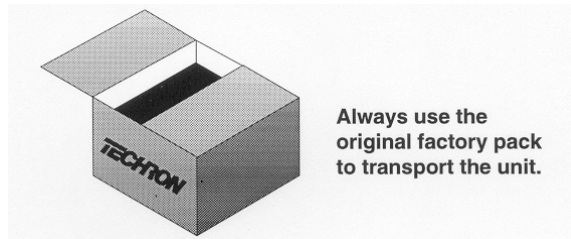

### **6.2 Shipping Instructions**

1. When sending an **AE TECHRON** product to the factory for service, be sure to write a letter describing the problem and reason for service and enclose it inside your unit's shipping pack.
2. To assure the safe transportation of your unit to the factory, ship it in an original factory-packing container. If you don't have one, call or write **AE TECHRON'S** Parts Department. With the exception of polyurethane or wooden crates, any other packing material will not be sufficient to withstand the stress of shipping. Do not use loose, small size packing materials.
3. Do not ship the unit in any kind of cabinet (wood or metal). Ignoring this warning may result in extensive damage to the unit and the cabinet. Accessories are not needed-do not send the instruction manual, cables or other hardware.
4. If you have any questions, please call or write the **AE TECHRON** Technical Support Group:

Phone: (574) 295-9495

Fax: (574) 295-9596

E-Mail: Sales@aetechron.com

5. Shipments to **AE TECHRON** should be made as described below:

**AE TECHRON**

2507 Warren Street

Elkhart, Indiana 46516 U.S.A.